



Chipsmall Limited consists of a professional team with an average of over 10 year of expertise in the distribution of electronic components. Based in Hongkong, we have already established firm and mutual-benefit business relationships with customers from,Europe,America and south Asia,supplying obsolete and hard-to-find components to meet their specific needs.

With the principle of “Quality Parts,Customers Priority,Honest Operation,and Considerate Service”,our business mainly focus on the distribution of electronic components. Line cards we deal with include Microchip,ALPS,ROHM,Xilinx,Pulse,ON,Everlight and Freescale. Main products comprise IC,Modules,Potentiometer,IC Socket,Relay,Connector.Our parts cover such applications as commercial,industrial, and automotives areas.

We are looking forward to setting up business relationship with you and hope to provide you with the best service and solution. Let us make a better world for our industry!



Contact us

Tel: +86-755-8981 8866 Fax: +86-755-8427 6832

Email & Skype: info@chipsmall.com Web: www.chipsmall.com

Address: A1208, Overseas Decoration Building, #122 Zhenhua RD., Futian, Shenzhen, China





Insertion Tool Instruction Sheet Order No. 11-02-0001 (HT-1807)

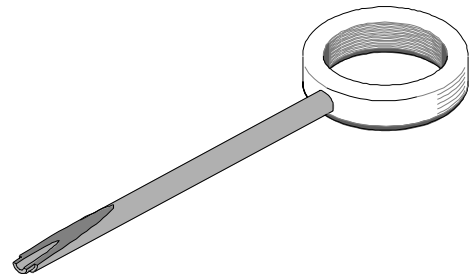

This Insertion tool is used for insertion of .062" diameter series pin and socket male and female terminals in plug and receptacle housings. This tool is designed to assure proper seating of terminals and reduce operator fatigue.

TERMINAL INSERTION:

Individual terminals may be inserted in the housing using this Insertion tool.

- 1) To properly use this tool, with the flat side facing up, place the ring over the ring finger past the first joint (See Figure 1). Place the wire in the groove of the tool so that the terminal is touching the end of tool (See Figure 2).*
- 2) With your thumb securely holding the wire in the groove, push the terminal into the housing as far as the shoulder on the tool will permit. The terminal then should be locked in place.*

Optional: The terminal can be partially inserted in the terminal housing first, and then the Insertion tool can be used to firmly seat the terminal.

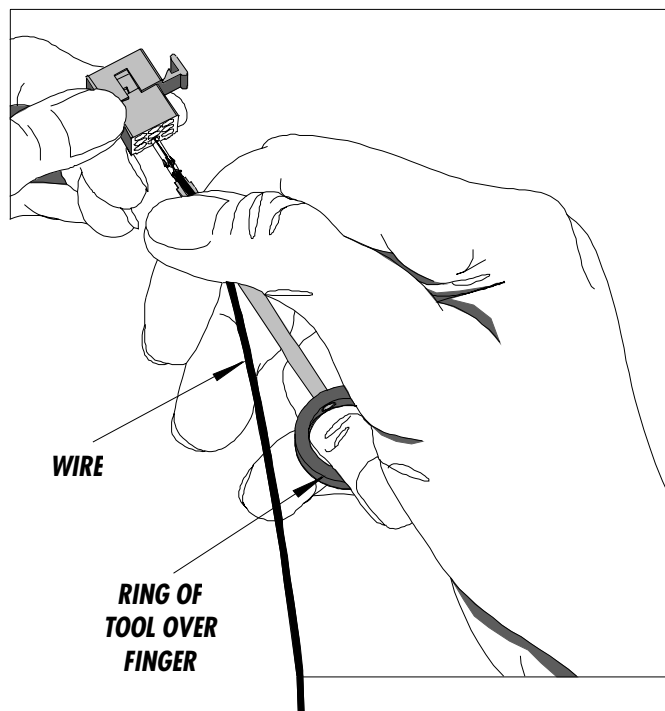

Figure 1

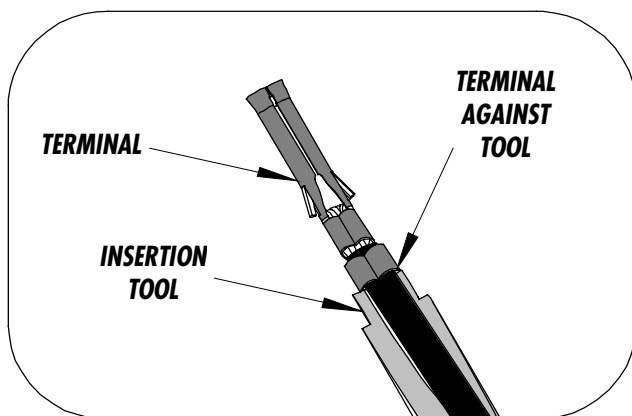

Figure 2

Molex Tooling Group
1150 E. Diehl Road
Naperville, IL 60563
(630) 969-4550; FAX (630) 505-0049