



Chipsmall Limited consists of a professional team with an average of over 10 year of expertise in the distribution of electronic components. Based in Hongkong, we have already established firm and mutual-benefit business relationships with customers from,Europe,America and south Asia,supplying obsolete and hard-to-find components to meet their specific needs.

With the principle of “Quality Parts,Customers Priority,Honest Operation,and Considerate Service”,our business mainly focus on the distribution of electronic components. Line cards we deal with include Microchip,ALPS,ROHM,Xilinx,Pulse,ON,Everlight and Freescale. Main products comprise IC,Modules,Potentiometer,IC Socket,Relay,Connector.Our parts cover such applications as commercial,industrial, and automotives areas.

We are looking forward to setting up business relationship with you and hope to provide you with the best service and solution. Let us make a better world for our industry!



## Contact us

Tel: +86-755-8981 8866 Fax: +86-755-8427 6832

Email & Skype: info@chipsmall.com Web: www.chipsmall.com

Address: A1208, Overseas Decoration Building, #122 Zhenhua RD., Futian, Shenzhen, China



<b>SPECIFICATION CONTROL DRAWING</b>	<b>0022S2662</b>
--------------------------------------	------------------

<b>CHEMINAX</b>	100 OHM, AWG 22, 19 STRANDS OF AWG 34, TWINAXIAL CABLE, OUTER SPACE USE	Date	1-10-12
		Revision	A

THIS SPECIFICATION SHEET FORMS A PART OF THE LATEST ISSUE OF RAYCHEM SPECIFICATION 1200.

<b>CONSTRUCTION DETAILS</b>	<b>ELECTRICAL CHARACTERISTICS</b>
-----------------------------	-----------------------------------

DIMENSIONS ARE NOMINAL VALUES IN INCHES UNLESS OTHERWISE DESIGNATED.

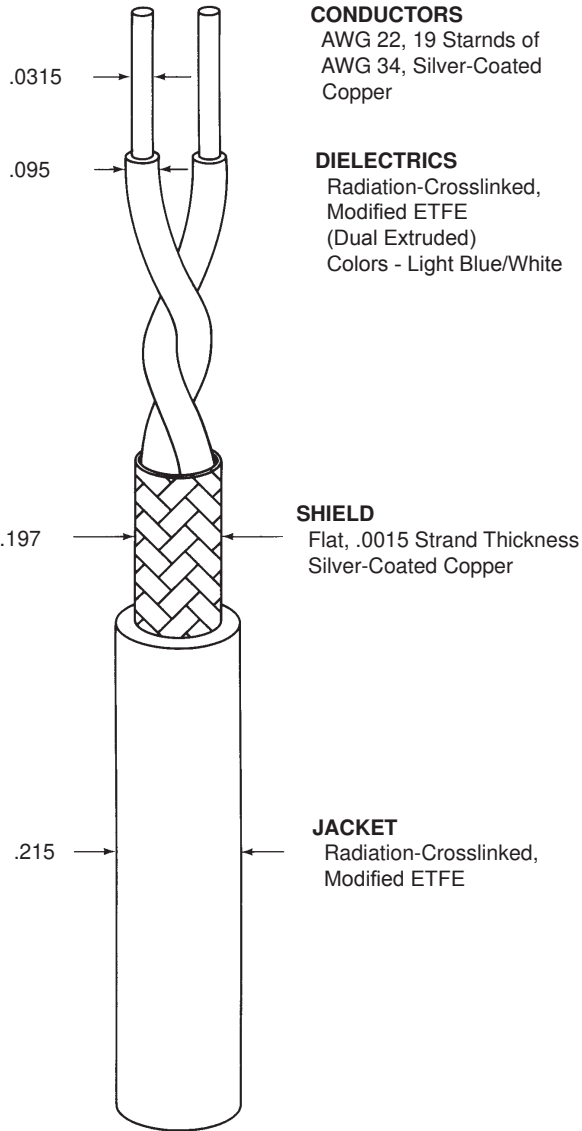

**CONDUCTORS**  
AWG 22, 19 Strands of  
AWG 34, Silver-Coated  
Copper

**DIELECTRICS**  
Radiation-Crosslinked,  
Modified ETFE  
(Dual Extruded)  
Colors - Light Blue/White

**SHIELD**  
Flat, .0015 Strand Thickness  
Silver-Coated Copper

**JACKET**  
Radiation-Crosslinked,  
Modified ETFE

CHARACTERISTIC IMPEDANCE	100 ± 10 ohms, Method C at 1 MHz
MUTUAL CAPACITANCE	18 pF/ft. (nominal)

**ADDITIONAL REQUIREMENTS**

**COMPONENT WIRE PRIOR TO CABLING (Test Procedures per SAE AS22759)**

CROSSLINKING PROOF TEST	300 ± 3°C for 1 hour, 1.00 inch mandrel, 1.00 lb., 2.5 kV dielectric test
INSULATION (DIELECTRIC) (total insulation)	
ELONGATION	50% (minimum)
TENSILE STRENGTH	5000 lbf/in <sup>2</sup> (minimum)
INSULATION FLAWS	
SPARK TEST	3.0 kV (rms)
IMPULSE TEST	8.0 kV (peak)
INSULATION RESISTANCE	5000 megohms for 1000 ft. (minimum)
LOW TEMPERATURE-COLD BEND	-65 ± 3°C for 4 hours, .750 inch mandrel, 1.00 lb., 2.5 kV dielectric test
SHRINKAGE	200 ± 3°C for 1 hour, .125 inch (maximum) in 12 inches

**FINISHED CABLE  
(Test Procedures per NEMA WC 27500, unless otherwise specified)**

BLOCKING	200°C for 6 hours
CROSSLINKED VERIFICATION	300 ± 5°C for 6 hours, 6.00 inch mandrel
FLAMMABILITY (Method B of Spec 1200)	3 seconds (maximum); 3 inches (maximum); no flaming of facial tissue
JACKET	
ELONGATION	50% (minimum)
TENSILE STRENGTH	5000 lbf/in <sup>2</sup> (minimum)
JACKET FLAWS	
SPARK TEST	1.0 kV (rms)
IMPULSE TEST	6.0 kV (peak)
JACKET THICKNESS	.009 inch (nominal)
LOW TEMPERATURE-COLD BEND	-55 ± 5°C for 4 hours, 6.00 inch mandrel
SHIELD COVERAGE	90% (minimum)
VOLTAGE WITHSTAND (DIELECTRIC)	1500 volts (rms)
WEIGHT	23.5 lbs/1000 ft. (nominal)

**OUTER SPACE REQUIREMENTS**

RADIATION RESISTANCE	500 megarads/6.50 inch mandrel 1.0 kV dielectric test
VACUUM STABILITY	
TOTAL MASS LOSS (TML)	1.00% (maximum)
VOLATILE CONDENSABLE	0.10% (maximum)
MATERIAL (VCM)	
WEIGHT LOSS (Per Raychem Spec 55/):	0.45% (maximum)

Outer jacket color will be white (designated by a "-9" appended to the part number, e.g. 0022S2662-9) unless otherwise specified.

Designate outer jacket color with a dash number in accordance with MIL-STD-681. Other codes and suffixes may be added to the part number, as necessary, to capture any additional requirements imposed by the purchase order.

Users should evaluate the suitability of this product for their application. Specifications are subject to change without notice. Tyco Electronics Corporation also reserves the right to make changes in materials or processing, which do not affect compliance with any specification, without notification to Buyer.

