



Chipsmall Limited consists of a professional team with an average of over 10 year of expertise in the distribution of electronic components. Based in Hongkong, we have already established firm and mutual-benefit business relationships with customers from,Europe,America and south Asia,supplying obsolete and hard-to-find components to meet their specific needs.

With the principle of “Quality Parts,Customers Priority,Honest Operation,and Considerate Service”,our business mainly focus on the distribution of electronic components. Line cards we deal with include Microchip,ALPS,ROHM,Xilinx,Pulse,ON,Everlight and Freescale. Main products comprise IC,Modules,Potentiometer,IC Socket,Relay,Connector.Our parts cover such applications as commercial,industrial, and automotives areas.

We are looking forward to setting up business relationship with you and hope to provide you with the best service and solution. Let us make a better world for our industry!



## Contact us

Tel: +86-755-8981 8866 Fax: +86-755-8427 6832

Email & Skype: info@chipsmall.com Web: www.chipsmall.com

Address: A1208, Overseas Decoration Building, #122 Zhenhua RD., Futian, Shenzhen, China



THIS SPECIFICATION SHEET FORMS A PART OF THE LATEST ISSUE OF RAYCHEM SPECIFICATION 1200.

**CONSTRUCTION DETAILS**

**ELECTRICAL CHARACTERISTICS**

DIMENSIONS ARE NOMINAL VALUES IN INCHES UNLESS OTHERWISE DESIGNATED.

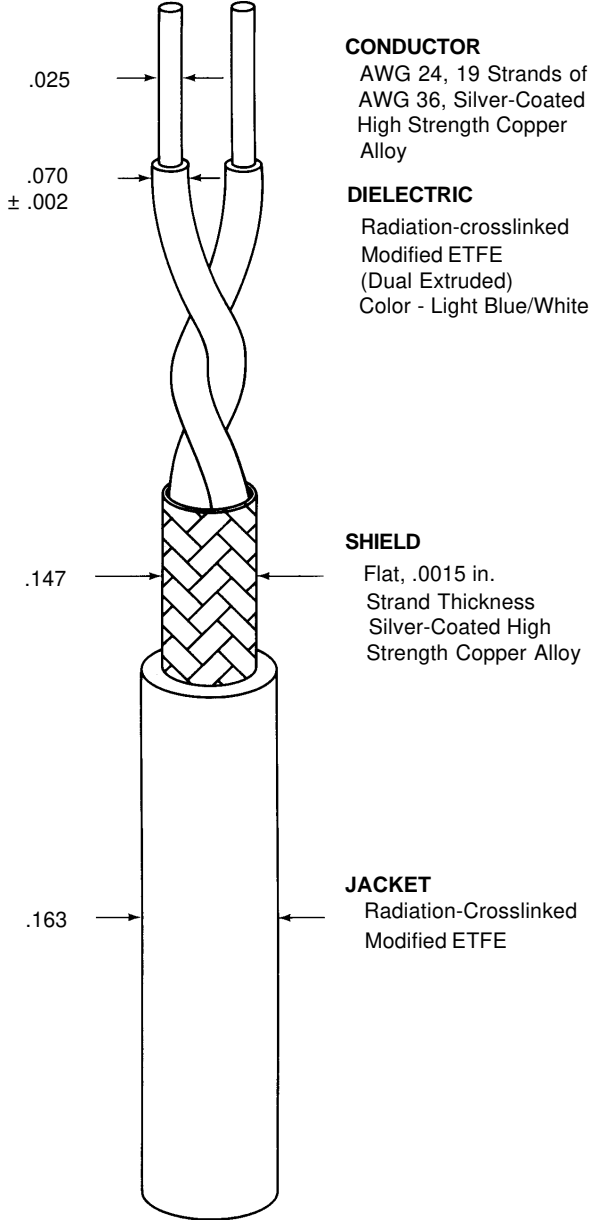

CHARACTERISTIC IMPEDANCE	100 ± 7 ohms, Method C at 1 MHz
CAPACITANCE - MUTUAL	18.5 pF/ft. (nominal)
VELOCITY	62% (nominal)

**ADDITIONAL REQUIREMENTS**

**COMPONENT WIRE PRIOR TO CABLING (Test Procedures per SAE AS22759)**

CROSSLINK PROOF	300 ± 3°C for 1 hour, .875 inch mandrel, .750 lb., 2.5 kV dielectric test
LOW TEMPERATURE COLD BEND	-65 ± 2°C for 4 hours, .500 inch mandrel, 1.00 lb., 2.5 kV dielectric test
SHRINKAGE	200 ± 3°C for 1 hour, .125 inch (maximum) in 12 inches
INSULATION RESISTANCE INSULATION (DIELECTRIC) (total insulation)	5000 megohms for 1000 ft. (minimum)
TENSILE STRENGTH ELONGATION	5000 lbf/in <sup>2</sup> (minimum) 50% (minimum)
INSULATION FLAWS SPARK TEST	3.0 kV (rms)
IMPULSE TEST	8.0 kV (peak)

**FINISHED CABLE (Test Procedures per NEMA WC27500)**

BLOCKING	200°C for 6 hours
LOW TEMPERATURE COLD BEND	-55 ± 5°C for 4 hours, 6.0 inch mandrel
CROSSLINKED VERIFICATION	300 ± 5°C for 6 hours, 6.0 inch mandrel
FLAMMABILITY (Method B per Spec. 1200)	3 seconds (maximum); 3.0 inches (maximum), no flaming of facial tissue
JACKET FLAWS SPARK TEST	1.0 kV (rms)
IMPULSE TEST	6.0 kV (peak)
JACKET TENSILE STRENGTH ELONGATION	5000 lbf/in <sup>2</sup> (minimum) 50% (minimum)
SHIELD COVERAGE	90% (minimum)
WALL THICKNESS	.008 (nominal), .005 (minimum)
VOLTAGE WITHSTAND (DIELECTRIC)	1500 volts (rms)
WEIGHT	14.1 lbs/1000 ft. (nominal)

**OUTER SPACE REQUIREMENTS**

RADIATION RESISTANCE	500 megarads/4.75 inch mandrel
VACUUM STABILITY TOTAL MASS LOSS (TML)	1.0% (maximum)
VOLATILE CONDENSABLE MATERIAL (VCM)	0.1% (maximum)
WEIGHT LOSS: (Test per Spec 55/)	0.45% (maximum)

Outer jacket color will be white (designated by a "-9" appended to the part number, e.g. 0024A2664-9) unless otherwise specified.

Designate outer jacket color with a dash number in accordance with MIL-STD-681. Other codes and suffixes may be added to the part number, as necessary, to capture any additional requirements imposed by the purchase order.

Users should evaluate the suitability of this product for their application. Specifications are subject to change without notice. Tyco Electronics also reserves the right to make changes in materials or processing, which do not affect compliance with any specification, without notification to Buyer.