



Chipsmall Limited consists of a professional team with an average of over 10 year of expertise in the distribution of electronic components. Based in Hongkong, we have already established firm and mutual-benefit business relationships with customers from,Europe,America and south Asia,supplying obsolete and hard-to-find components to meet their specific needs.

With the principle of “Quality Parts,Customers Priority,Honest Operation,and Considerate Service”,our business mainly focus on the distribution of electronic components. Line cards we deal with include Microchip,ALPS,ROHM,Xilinx,Pulse,ON,Everlight and Freescale. Main products comprise IC,Modules,Potentiometer,IC Socket,Relay,Connector.Our parts cover such applications as commercial,industrial, and automotives areas.

We are looking forward to setting up business relationship with you and hope to provide you with the best service and solution. Let us make a better world for our industry!



Contact us

Tel: +86-755-8981 8866 Fax: +86-755-8427 6832

Email & Skype: info@chipsmall.com Web: www.chipsmall.com

Address: A1208, Overseas Decoration Building, #122 Zhenhua RD., Futian, Shenzhen, China



THIS INFORMATION IS CONFIDENTIAL AND PROPRIETARY TO LAIRD TECHNOLOGIES.
IT MAY NOT BE DISCLOSED TO ANYONE, OTHER THAN LAIRD TECHNOLOGIES
PERSONNEL, WITHOUT WRITTEN AUTHORIZATION FROM LAIRD TECHNOLOGIES.

DWG. NO. 0077-0068
ADDED TOLERANCE TW 11/24/08 02

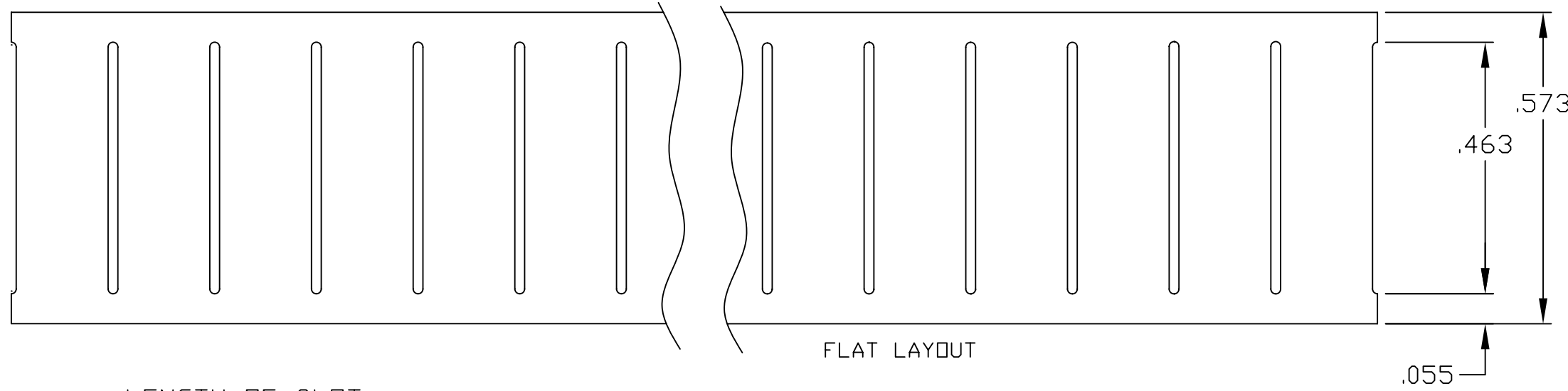
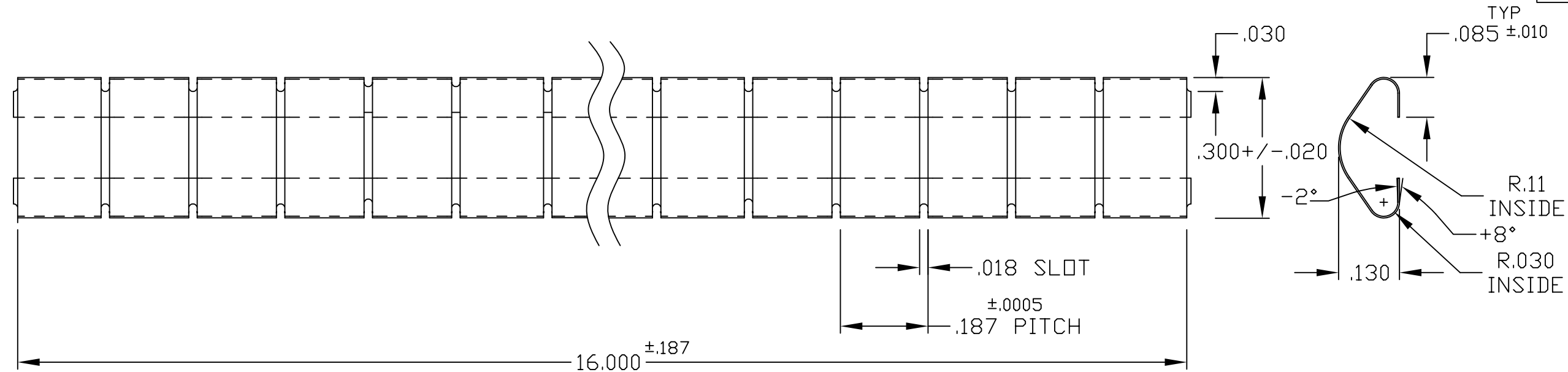

ECO # AC084911
CUSTOMER
LT-PART # REV 02
APPROVED
By Tim Wrona at 12:51 pm, Dec 03, 2008

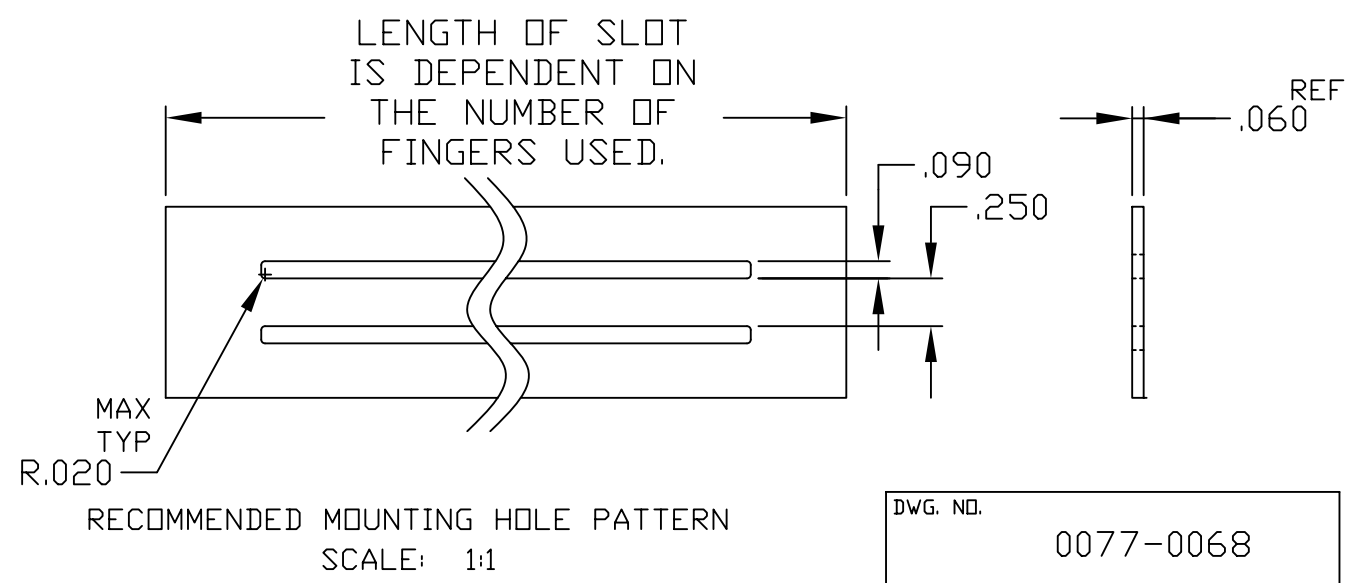

DWG. NO. 0077-0068

MATERIAL:	.0035±.0002 X .564±.003 BeCu ALLOY 25 1/4 HARD ENDURANCE GRADE	TOLERANCES NOT SHOWN	
HEAT TREATED:	TO DPH 373 MINIMUM USING A 500 GRAM LOAD	DECIMAL 2 PL'S ± .020	
THICKNESS AFTER:	CLEANING AND BEFORE PLATING: .00315 MIN.	DECIMAL 3 PL'S ± .005	
FINISH:	AS REQUIRED	ANGULAR ± ---	
		THIRD ANGLE PROJECTION	
		UNITS: INCH [MM]	SCALE: 4:1
CAD MAINTAINED DRAWING. MANUAL CHANGES UNAUTHORIZED.			

Laird TECHNOLOGIES	DRAWN BY:	RKM	DATE:	08/26/03	
	CHECKED BY:	DPG	DATE:	08/26/03	
	APPROVED BY:	EWS	DATE:	08/26/03	
DELAWARE WATER GAP PENNSYLVANIA					
LAIRD STANDARD					
REF. DWG. NO. SLOT MOUNT GASKET					
DWG. NO. 0077-0068				SUB	02

