



Chipsmall Limited consists of a professional team with an average of over 10 year of expertise in the distribution of electronic components. Based in Hongkong, we have already established firm and mutual-benefit business relationships with customers from,Europe,America and south Asia,supplying obsolete and hard-to-find components to meet their specific needs.

With the principle of “Quality Parts,Customers Priority,Honest Operation,and Considerate Service”,our business mainly focus on the distribution of electronic components. Line cards we deal with include Microchip,ALPS,ROHM,Xilinx,Pulse,ON,Everlight and Freescale. Main products comprise IC,Modules,Potentiometer,IC Socket,Relay,Connector.Our parts cover such applications as commercial,industrial, and automotives areas.

We are looking forward to setting up business relationship with you and hope to provide you with the best service and solution. Let us make a better world for our industry!



Contact us

Tel: +86-755-8981 8866 Fax: +86-755-8427 6832

Email & Skype: info@chipsmall.com Web: www.chipsmall.com

Address: A1208, Overseas Decoration Building, #122 Zhenhua RD., Futian, Shenzhen, China



Omni Marker™ Installation Instructions

Congratulations on your purchase of the finest electronic marker available today. Please follow these simple instructions to ensure proper operation of your Omni Marker™ for years to come.

1. Determine whether or not the Omni Marker™ needs to be secured to the object being marked. If so, attach the marker with one or two cable ties as necessary.

IMPORTANT

- If the object being marked is metallic, the marker should be placed at least four inches (10.2 cm) above the object and the space between should be filled with soil. If the object being marked is non-metallic, the marker can be placed directly over the object.
 - Omni Marker™ can be reliably detected if the distance between the locator and the marker is five feet (1.5 meters) or less. Do not bury the marker deeper than this.
2. Place the marker over the object to be marked as shown below. **The marker can be buried in any orientation.**
 3. Cover the marker with six inches (15.2 cm) of soil to prevent movement during backfill.
 4. Backfill the hole or trench normally.

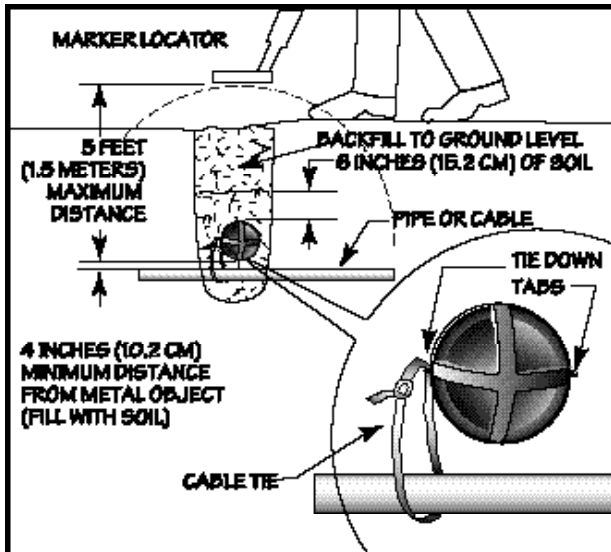

Omni Marker™ is a trademark of Tempo®. Patent numbers 5,699,048, 6,097,293, other patents pending. ©2002 Tempo Research Corporation - All Rights Reserved



Telephone: +1 815 397-4279
Toll-free in the US and Canada: 1 800 282-7941
Facsimile: +1 815 397-1865
www.tempo.textron.com



Omni Marker™ Installation Instructions

Congratulations on your purchase of the finest electronic marker available today. Please follow these simple instructions to ensure proper operation of your Omni Marker™ for years to come.

1. Determine whether or not the Omni Marker™ needs to be secured to the object being marked. If so, attach the marker with one or two cable ties as necessary.

IMPORTANT

- If the object being marked is metallic, the marker should be placed at least four inches (10.2 cm) above the object and the space between should be filled with soil. If the object being marked is non-metallic, the marker can be placed directly over the object.
 - Omni Marker™ can be reliably detected if the distance between the locator and the marker is five feet (1.5 meters) or less. Do not bury the marker deeper than this.
2. Place the marker over the object to be marked as shown below. **The marker can be buried in any orientation.**
 3. Cover the marker with six inches (15.2 cm) of soil to prevent movement during backfill.
 4. Backfill the hole or trench normally.

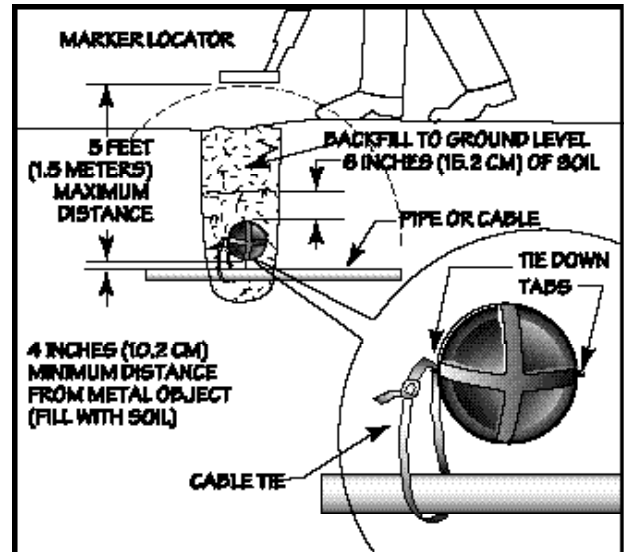

Omni Marker is a trademark of Tempo®. Patent numbers 5,699,048, 6,097,293, other patents pending. ©2002 Tempo Research Corporation - All Rights Reserved



Telephone: +1 815 397-4279
Toll-free in the US and Canada: 1 800 282-7941
Facsimile: +1 815 397-1865
www.tempo.textron.com



IMPORTANT NOTICE TO PURCHASER

All statements, technical information and recommendations contained herein are based on information we believe to be reliable, but the accuracy or completeness thereof is not guaranteed, and the following is made in lieu of all warranties, expressed or implied:

Tempo's only obligation shall be to repair or replace any product that proves to be defective within the warranty period. This warranty does not include normal wear and tear, and does not include units which in the opinion of Tempo® have been subject to neglect or abuse or units which have been altered in any way.

Neither seller or manufacturer shall be liable for injury, loss or damage, direct or consequential, arising out of use of this product. Before using, user shall determine the suitability of the product for his intended use, and user assumes all risk and liability in connection therewith. No statement or recommendation not contained herein shall have any force or effect unless in an agreement signed by officers of Tempo®.



IMPORTANT NOTICE TO PURCHASER

All statements, technical information and recommendations contained herein are based on information we believe to be reliable, but the accuracy or completeness thereof is not guaranteed, and the following is made in lieu of all warranties, expressed or implied:

Tempo's only obligation shall be to repair or replace any product that proves to be defective within the warranty period. This warranty does not include normal wear and tear, and does not include units which in the opinion of Tempo® have been subject to neglect or abuse or units which have been altered in any way.

Neither seller or manufacturer shall be liable for injury, loss or damage, direct or consequential, arising out of use of this product. Before using, user shall determine the suitability of the product for his intended use, and user assumes all risk and liability in connection therewith. No statement or recommendation not contained herein shall have any force or effect unless in an agreement signed by officers of Tempo®.

