



Chipsmall Limited consists of a professional team with an average of over 10 year of expertise in the distribution of electronic components. Based in Hongkong, we have already established firm and mutual-benefit business relationships with customers from,Europe,America and south Asia,supplying obsolete and hard-to-find components to meet their specific needs.

With the principle of "Quality Parts,Customers Priority,Honest Operation,and Considerate Service",our business mainly focus on the distribution of electronic components. Line cards we deal with include Microchip,ALPS,ROHM,Xilinx,Pulse,ON,Everlight and Freescale. Main products comprise IC,Modules,Potentiometer,IC Socket,Relay,Connector.Our parts cover such applications as commercial,industrial, and automotives areas.

We are looking forward to setting up business relationship with you and hope to provide you with the best service and solution. Let us make a better world for our industry!



Contact us

Tel: +86-755-8981 8866 Fax: +86-755-8427 6832

Email & Skype: info@chipsmall.com Web: www.chipsmall.com

Address: A1208, Overseas Decoration Building, #122 Zhenhua RD., Futian, Shenzhen, China



MATERIAL NUMBER ON STRIP	ENGINEERING NUMBER ON STRIP	MATERIAL NUMBER LOOSE PIECE	ENGINEERING NUMBER LOOSE PIECE	TAPE MATERIAL NUMBER	TAPE ENGINEERING NUMBER	AWG	TAB SIZE	D MAX
190080008	AAZ-1147	190080001	AA-1147	190080004	AA-1147T	22-18	.187 X .020	.257/6.53
190080009	AAZ-1147-032	190080002	AA-1147-032	190080003	AA-1147-032T	22-18	.187 X .032	.257/6.53
190080013	AAZ-1158	190080006	AA-1158	190080007	AA-1158T	22-18	.250 X .032	.312/7.92
190080028	BBZ-1148	190080019	BB-1148	190080022	BB-1148T	16-14	.187 X .020	.257/6.53
190080029	BBZ-1148-032	190080020	BB-1148-032	190080021	BB-1148-032T	16-14	.187 X .032	.257/6.53
190080031	BBZ-1159	190080024	BB-1159	190080027	BB-1159T	16-14	.250 X .032	.312/7.92

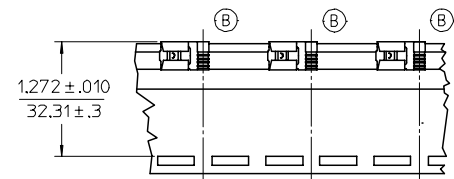

PARTS ON TAPE

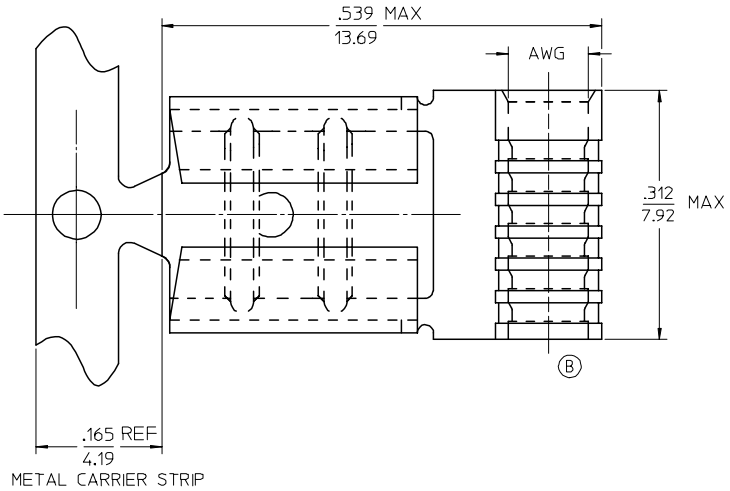

METAL CARRIER STRIP

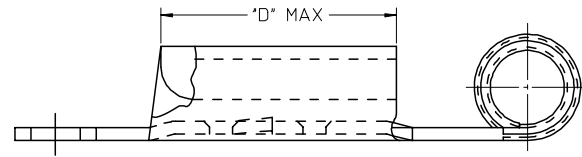
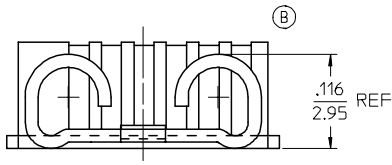

SALES DRAWING

NOTES:

- MATERIAL: BRASS .016/0.04 THICK. PLATING ELECTRO-TIN.
- TAB SIZE SEE CHART.
- WIRE AWG SEE CHART.
- (B) PART IS ROHS COMPLIANT.

REVISED BARREL & CHART FC NO: ETC2007-0001 DRAWN BY: DRW:NEHLE CHKD: JMACNEIL APPR: RDEROSS 2006/07/13 2006/07/17 2006/07/17	QUALITY SYMBOLS	GENERAL TOLERANCES (UNLESS SPECIFIED)	DIMENSION STYLE	SCALE	DESIGN UNITS	THIRD ANGLE PROJECTION															
	$\nabla=0$ $\nabla=0$	<table border="1"> <thead> <tr> <th></th> <th>mm</th> <th>INCH</th> </tr> </thead> <tbody> <tr> <td>4 PLACES</td> <td>± .005</td> <td>± .0005</td> </tr> <tr> <td>3 PLACES</td> <td>± .005</td> <td>± .0005</td> </tr> <tr> <td>2 PLACES</td> <td>± .13</td> <td>± .01</td> </tr> <tr> <td>1 PLACE</td> <td>± .25</td> <td>± .01</td> </tr> </tbody> </table>		mm	INCH	4 PLACES	± .005	± .0005	3 PLACES	± .005	± .0005	2 PLACES	± .13	± .01	1 PLACE	± .25	± .01	IN/MM	NONE	INCH	<input checked="" type="checkbox"/> THIRD ANGLE PROJECTION
		mm	INCH																		
	4 PLACES	± .005	± .0005																		
3 PLACES	± .005	± .0005																			
2 PLACES	± .13	± .01																			
1 PLACE	± .25	± .01																			
DESCRIPTION	MATERIAL NO.	DATE	TITLE	FLAG QD 22-18 AWG & 16-14 AWG .187X.020&.032,.250X.032																	
	SEE CHART	2005/01/25	2005/01/25	MOLEX INCORPORATED SD-19008-013																	