



Chipsmall Limited consists of a professional team with an average of over 10 year of expertise in the distribution of electronic components. Based in Hongkong, we have already established firm and mutual-benefit business relationships with customers from,Europe,America and south Asia,supplying obsolete and hard-to-find components to meet their specific needs.

With the principle of “Quality Parts,Customers Priority,Honest Operation,and Considerate Service”,our business mainly focus on the distribution of electronic components. Line cards we deal with include Microchip,ALPS,ROHM,Xilinx,Pulse,ON,Everlight and Freescale. Main products comprise IC,Modules,Potentiometer,IC Socket,Relay,Connector.Our parts cover such applications as commercial,industrial, and automotives areas.

We are looking forward to setting up business relationship with you and hope to provide you with the best service and solution. Let us make a better world for our industry!



Contact us

Tel: +86-755-8981 8866 Fax: +86-755-8427 6832

Email & Skype: info@chipsmall.com Web: www.chipsmall.com

Address: A1208, Overseas Decoration Building, #122 Zhenhua RD., Futian, Shenzhen, China



LOOSE PIECE		TAPE MOUNTED		CONTINUOUS STRIP		SPECIFICATIONS								
MATERIAL NUMBER	ENGINEERING NUMBER	MATERIAL NUMBER	ENGINEERING NUMBER	MATERIAL NUMBER	ENGINEERING NUMBER	INS. COLOR	WIRE RANGE AWG	MM ²	FITS MALE TAB SIZE	STOCK THICKNESS	"L" MAX.	"I" MAX.	"W" MAX.	MWID
192750002	AA-8140-LIF	192750003	AA-8140T-LIF	192750001	AAZ-8140-LIF	RED	22-18/	0.25-1.5	.250x.032 / 6.35x0.81	.016 / 0.41	.87 / 22.0	.43 / 10.9	.31 / 7.9	.115 / 2.92
192750005	BB-8141-LIF	192750006	BB-8141T-LIF	192750004	BBZ-8141-LIF	BLUE	16-14/	1.0-2.5	.250x.032 / 6.35x0.81	.016 / 0.41	.87 / 22.0	.43 / 10.9	.31 / 7.9	.138 / 3.51

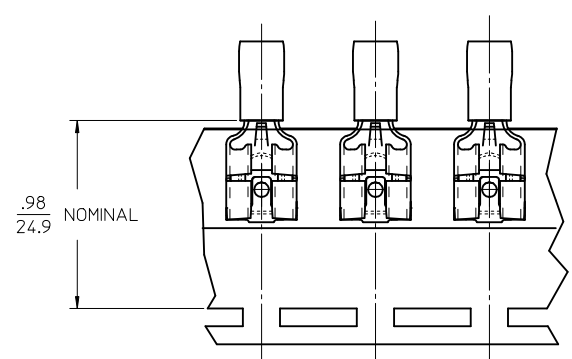
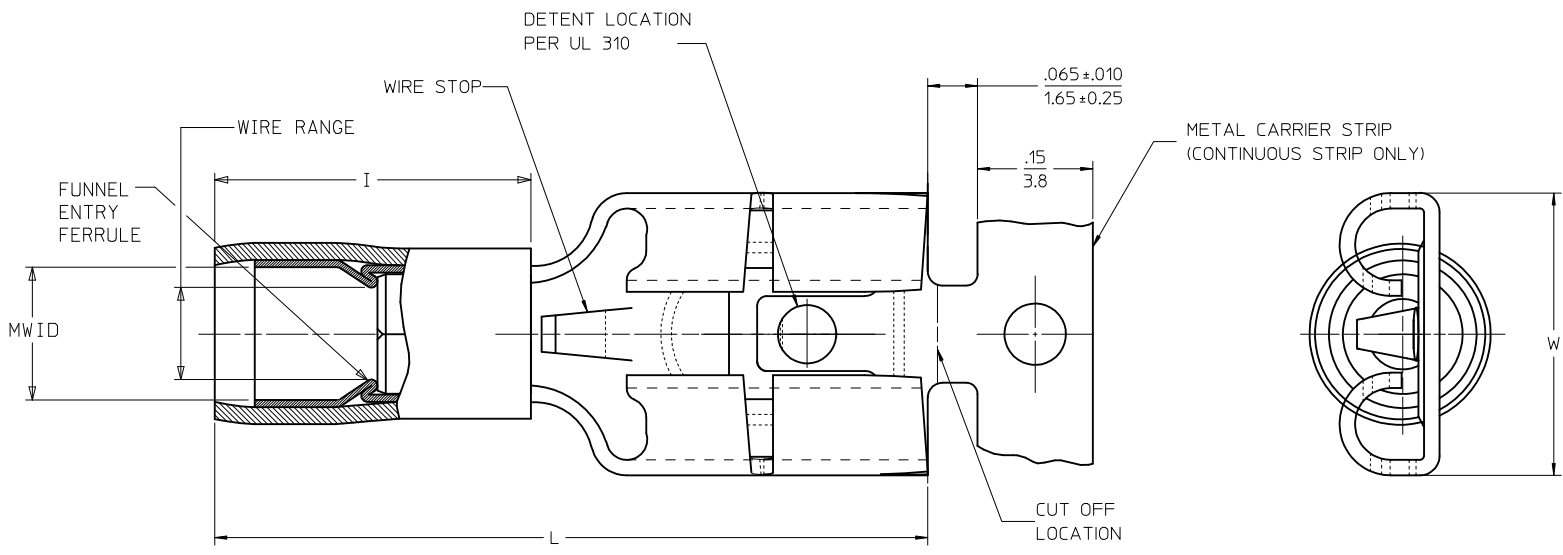

PARTS ON TAPE

NOTES:

- MATERIALS:
 TERMINAL: MATTE-TIN PLATED BRASS
 FERRULE: MATTE-TIN PLATED COPPER ALLOY
 INSULATION: NYLON 6/6 94V-2,
 SEE CHART FOR COLORS
- PRODUCT SPECIFICATION: PS-19902-012
- MWID = MAXIMUM WIRE INSULATION DIAMETER
- PARTS ARE ROHS COMPLIANT

FERRULE DESCR. CONT P/N EC NO: MNA2009-0761 DRW: ETHRODAHL 2010/03/18 CHKD: JMACNEIL 2010/03/18 APPR: JMACNEIL 2011/01/06	QUALITY SYMBOLS ▽=0 ▽=0	GENERAL TOLERANCES (UNLESS SPECIFIED)		DIMENSION STYLE	SCALE	DESIGN UNITS	THIRD ANGLE PROJECTION
				IN/MM	1:1	INCH	
				DRAWN BY	DATE	TITLE	
				CHECKED BY	DATE	QUIXON LOW INSERT FORCE PARTIAL INSUL QUICK DISC AVIKRIMP 22-14 AWG	
		ANGULAR ±1/2°		APPROVED BY	DATE	MOLEX MOLEX INCORPORATED	
		DRAFT WHERE APPLICABLE MUST REMAIN WITHIN DIMENSIONS		MATERIAL NO.	DOCUMENT NO.	SHEET NO. 1 OF 1	
				SEE CHART	SD-19275-001		
		THIS DRAWING CONTAINS INFORMATION THAT IS PROPRIETARY TO MOLEX INCORPORATED AND SHOULD NOT BE USED WITHOUT WRITTEN PERMISSION					