



Chipsmall Limited consists of a professional team with an average of over 10 year of expertise in the distribution of electronic components. Based in Hongkong, we have already established firm and mutual-benefit business relationships with customers from,Europe,America and south Asia,supplying obsolete and hard-to-find components to meet their specific needs.

With the principle of "Quality Parts,Customers Priority,Honest Operation,and Considerate Service",our business mainly focus on the distribution of electronic components. Line cards we deal with include Microchip,ALPS,ROHM,Xilinx,Pulse,ON,Everlight and Freescale. Main products comprise IC,Modules,Potentiometer,IC Socket,Relay,Connector.Our parts cover such applications as commercial,industrial, and automotives areas.

We are looking forward to setting up business relationship with you and hope to provide you with the best service and solution. Let us make a better world for our industry!



Contact us

Tel: +86-755-8981 8866 Fax: +86-755-8427 6832

Email & Skype: info@chipsmall.com Web: www.chipsmall.com

Address: A1208, Overseas Decoration Building, #122 Zhenhua RD., Futian, Shenzhen, China





ITT

Interconnect Solutions
Cannon, VEAM, BIW

Defining **innovative**
aviation, military, and
industrial circulars since the DC-1,
over **70 years** ago



Engineered for life

CA-KE MIL-DTL-5015 Type Firewall Connectors



A

Circular

Washing, fuel spillage, and atmospheric variations are responsible for the development of firewall connectors that combine moisture resistance with fireproof characteristics. The CA-KE series provide environmental resistance to meet the moisture problems as well as emergency fire conditions defined by MIL-DTL-5015. CA-KE connectors are fully interchangeable and intermateable with other 5015 type of connectors. In order to maintain the moisture seal and fire resistance, however, they must mate with corresponding CA-KE connectors.

Continuous operating temperature of +177° C (+350° F) - crimp contacts. Moisture resistant connector for use with sealable wires. Modifications of MS31**K configuration.

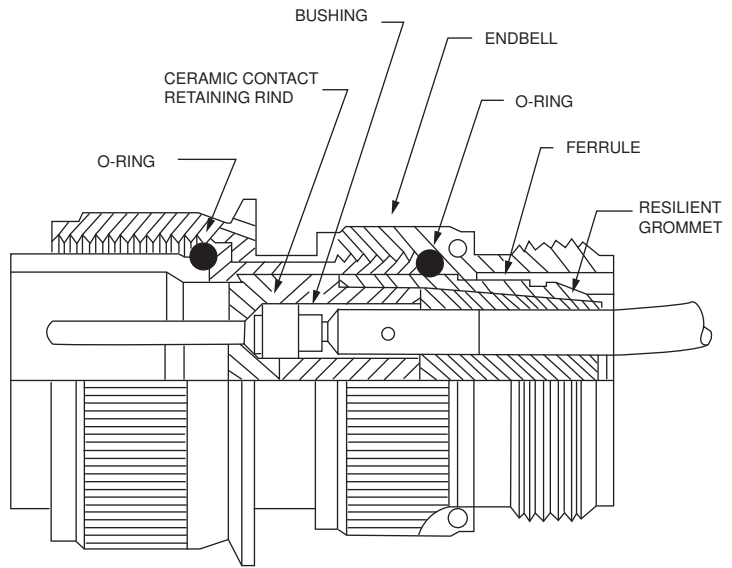

Performance and Material Specifications

MATERIALS

- Shell - Steel
- Insulator - Glass-filled epoxy or glass-filled melamine
- Contacts - Copper alloy
- Grommet and O Ring - Fuel-resistant silicone rubber
- Accessory Hardware - Steel

FINISHES

- Shell - Olive drab over cadmium plate
- Contacts - Silver plate
- Accessory Hardware - Olive drab over cadmium plate

MECHANICAL FEATURES

- Shell Size - In sixteenths of an inch
- Coupling - Threaded
- Contact Arrangements - See page A-127

ELECTRICAL DATA

- Number of Contacts - 1 thru 47

How to Order

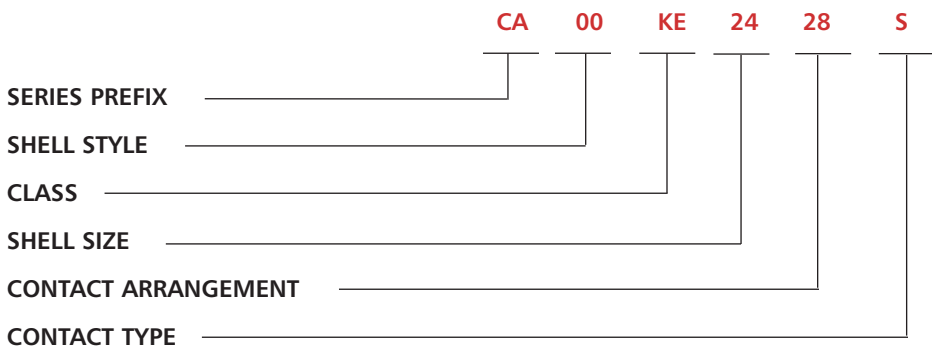

SERIES PREFIX

CA

SHELL STYLE

- 00 - Wall mounting receptacle (without conduit threads)
- 06 - Straight plug (without conduit threads)
- 3100 - Wall mounting receptacle
- 3106 - Straight plug

CLASS

KE - Environment-resistant firewall connector

SHELL SIZE

8S to 36

CONTACT ARRANGEMENT

See page A-127

CONTACT TYPE

P for Pin; S for Socket



Dimensions shown in inches (mm)
Specifications and dimensions subject to change

www.ittcannon.com



A

Circular

Wall Mounting Receptacle

CA00KE

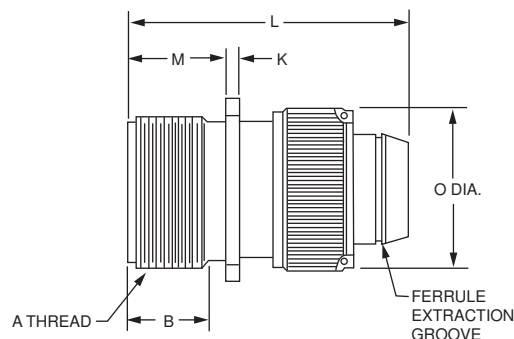
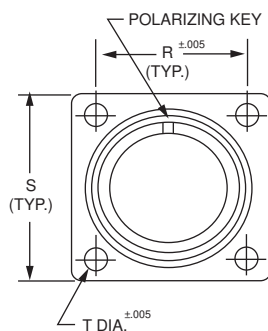

Part Number	A Thread	B	K	L	M	O	R	S	T
CA00KE8S-†	1/2-28UNEF-2A	.375 (9.52)	.063 (1.60)	1.687 (42.85)	.578 (14.68)	.531 (13.49)	.594 (15.09)	.875 (22.22)	.150 (3.81)
CA00KE10S-†	5/8-24UNEF-2A	.375 (9.52)	.063 (1.60)	1.687 (42.85)	.578 (14.68)	.687 (17.45)	.719 (18.26)	1.000 (25.40)	.150 (3.81)
• CA00KE10S-†	5/8-24UNEF-2A	.375 (9.52)	.063 (1.60)	1.781 (45.24)	.578 (14.68)	.687 (17.45)	.719 (18.26)	1.000 (25.40)	.150 (3.81)
CA00KE12S-†	3/4-20UNEF-2A	.375 (9.52)	.063 (1.60)	1.687 (42.85)	.578 (14.68)	.781 (19.84)	.812 (20.62)	1.094 (27.79)	.150 (3.81)
CA00KE14S-†	7/8-20UNEF-2A	.375 (9.52)	.063 (1.60)	1.687 (42.85)	.578 (14.68)	.906 (23.01)	.906 (23.01)	1.188 (30.18)	.150 (3.81)
CA00KE16S-†	1-20UNEF-2A	.375 (9.52)	.063 (1.90)	1.687 (42.85)	.578 (14.68)	1.031 (26.19)	.969 (24.62)	1.281 (32.54)	.150 (3.81)
CA00KE16-†	1-20UNEF-2A	.625 (15.88)	.078 (1.98)	2.094 (53.19)	.766 (19.46)	1.031 (26.19)	.969 (24.62)	1.281 (32.54)	.150 (3.81)
CA00KE18-†	1-1/8-18UNEF-2A	.625 (15.88)	.078 (1.98)	2.250 (57.15)	.766 (19.46)	1.156 (29.36)	1.062 (26.97)	1.375 (34.92)	.117 (4.50)
CA00KE20-†	1-1/4-18UNEF-2A	.625 (15.88)	.078 (1.98)	2.250 (57.15)	.766 (19.46)	1.344 (34.14)	1.156 (29.36)	1.500 (38.10)	.117 (4.50)
CA00KE22-†	1-3/8-18UNEF-2A	.625 (15.88)	.078 (1.98)	2.250 (57.15)	.828 (21.03)	1.406 (35.71)	1.250 (31.75)	1.625 (41.28)	.117 (4.50)
CA00KE24-†	1-1/2-18UNEF-2A	.625 (15.88)	.078 (1.98)	2.250 (57.15)	.828 (21.03)	1.625 (41.28)	1.375 (34.92)	1.750 (44.45)	.117 (4.50)
CA00KE28-†	1-3/4-18UNS-2A	.625 (15.88)	.078 (1.98)	2.250 (57.15)	.891 (22.63)	1.781 (45.24)	1.562 (39.67)	2.000 (50.80)	.117 (4.50)
CA00KE32-†	2-18UNS-2A	.625 (15.88)	.078 (1.98)	2.250 (57.15)	.891 (22.63)	2.031 (51.59)	1.750 (44.45)	2.250 (57.15)	.209 (5.31)
CA00KE36-†	2-1/4-16UNS-2A	.625 (15.88)	.094 (2.39)	2.250 (57.15)	.891 (22.63)	2.281 (57.94)	1.938 (49.23)	2.500 (63.50)	.209 (5.31)

• Receptacles in size 10SL are available with pin inserts only

* Add contact arrangements. See page A-127.

† Add contact type: P - pin; S - socket

Straight Plug (without Conduit Threads)

CA06KE

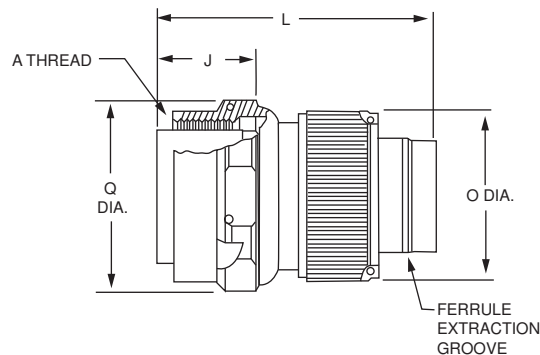
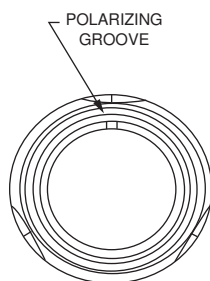

Part Number	A Thread	J	L	O	Q
CA06KE8S-†	1/2-28UNEF-2B	.531 (13.49)	1.687 (42.85)	.531 (13.49)	.828 (21.03)
CA06KE10S-†	5/8-24UNEF-2B	.531 (13.49)	1.687 (42.85)	.687 (17.45)	.969 (24.62)
• CA06KE10S-†	5/8-24UNEF-2B	.531 (13.49)	1.687 (42.85)	.781 (19.84)	.969 (24.62)
CA06KE12S-†	3/4-20UNEF-2B	.531 (13.49)	1.687 (42.85)	.781 (19.84)	1.047 (26.59)
CA06KE14S-†	7/8-20UNEF-2B	.531 (13.49)	1.687 (42.85)	.906 (23.01)	1.125 (28.58)
CA06KE16S-†	1-20UNEF-2B	.531 (13.49)	1.687 (42.85)	1.031 (26.19)	1.250 (31.75)
CA06KE16-†	1-20UNEF-2B	.719 (18.26)	2.094 (53.19)	1.031 (26.19)	1.250 (31.75)
CA06KE18-†	1-1/8-18UNEF-2B	.719 (18.26)	2.250 (57.15)	1.156 (29.36)	1.344 (34.14)
CA06KE20-†	1-1/4-18UNEF-2B	.719 (18.26)	2.250 (57.15)	1.344 (34.14)	1.484 (37.69)
CA06KE22-†	1-3/8-18UNEF-2B	.719 (18.26)	2.250 (57.15)	1.406 (35.71)	1.609 (40.87)
CA06KE24-†	1-1/2-18UNEF-2B	.719 (18.26)	2.250 (57.15)	1.625 (41.28)	1.734 (44.04)
CA06KE28-†	1-3/4-18UNS-2B	.719 (18.26)	2.250 (57.15)	1.781 (45.24)	1.984 (50.39)
CA06KE32-†	2-18UNS-2B	.719 (18.26)	2.250 (57.15)	2.031 (51.59)	2.234 (56.74)
CA06KE36-†	2-1/4-16UNS-2B	.719 (18.26)	2.250 (57.15)	2.281 (57.94)	2.484 (63.09)

• Plugs in size 10SL are available with socket inserts only.

* Add contact arrangements. See page A-127.

† Add contact type: P - pin; S - socket

NOTE: Coupling nut has hex configuration on sizes 8S, 10S, 10SL, 12 and 24; knurled configuration on all others.

Dimensions shown in inches (mm)
Specifications and dimensions subject to change

www.ittcannon.com



CA-KE MIL-DTL-5015 Type Firewall Connectors



A

Circular

Wall Mounting Receptacle

CA3100KE

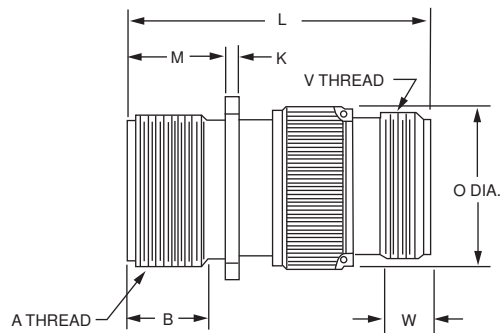
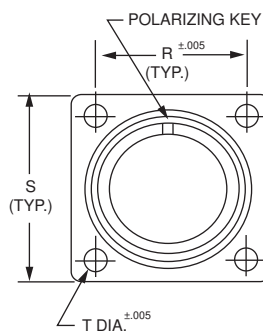

Part Number	A Thread	B	K	L	M	O	R	S	T	V Thread	W
CA3100KE8S-†	1/2-28UNEF-2A	.375 (9.52)	.063 (1.60)	2.000 (50.80)	.578 (14.68)	.531 (13.49)	.594 (15.09)	.875 (22.22)	.150 (3.81)	1/2-28UNEF-2A	.375 (9.52)
CA3100KE10S-†	5/8-24UNEF-2A	.375 (9.52)	.063 (1.60)	2.000 (50.80)	.578 (14.68)	.687 (17.45)	.719 (18.26)	1.000 (25.40)	.150 (3.81)	1/2-24UNEF-2A	.375 (9.52)
• CA3100KE10S-†	5/8-24UNEF-2A	.375 (9.52)	.063 (1.60)	2.000 (50.80)	.578 (14.68)	.687 (17.45)	.719 (18.26)	1.000 (25.40)	.150 (3.81)	5/8-24UNEF-2A	.375 (9.52)
CA3100KE12S-†	3/4-20UNEF-2A	.375 (9.52)	.063 (1.60)	2.000 (50.80)	.578 (14.68)	.781 (19.84)	.812 (20.62)	1.094 (27.79)	.150 (3.81)	5/8-20UNEF-2A	.375 (9.52)
CA3100KE14S-†	7/8-20UNEF-2A	.375 (9.52)	.063 (1.60)	2.000 (50.80)	.578 (14.68)	.906 (23.01)	.906 (23.01)	1.188 (30.18)	.150 (3.81)	3/4-20UNEF-2A	.375 (9.52)
CA3100KE16S-†	1-20UNEF-2A	.375 (9.52)	.063 (1.90)	2.000 (50.80)	.578 (14.68)	1.031 (26.19)	.969 (24.62)	1.281 (32.54)	.150 (3.81)	7/8-20UNEF-2A	.375 (9.52)
CA3100KE16-†	1-20UNEF-2A	.625 (15.88)	.078 (1.98)	2.188 (55.58)	.766 (19.46)	1.031 (26.19)	.969 (24.62)	1.281 (32.54)	.150 (3.81)	7/8-20UNEF-2A	.375 (9.52)
CA3100KE18-†	1-1/8-18UNEF-2A	.625 (15.88)	.078 (1.98)	2.250 (57.15)	.766 (19.46)	1.156 (29.36)	1.062 (26.97)	1.375 (34.92)	.177 (4.50)	1-20UNEF-2A	.375 (9.52)
CA3100KE20-†	1-1/4-18UNEF-2A	.625 (15.88)	.078 (1.98)	2.313 (58.75)	.766 (19.46)	1.344 (34.14)	1.156 (29.36)	1.500 (38.10)	.177 (4.50)	1-3/16-18UNEF-2A	.375 (9.52)
CA3100KE22-†	1-3/8-18UNEF-2A	.625 (15.88)	.078 (1.98)	2.313 (58.75)	.828 (21.03)	1.406 (35.71)	1.250 (31.75)	1.625 (41.28)	.177 (4.50)	1-3/16-18UNEF-2A	.375 (9.52)
CA3100KE24-†	1-1/2-18UNEF-2A	.625 (15.88)	.078 (1.98)	2.313 (58.75)	.828 (21.03)	1.625 (41.28)	1.375 (34.92)	1.750 (44.45)	.177 (4.50)	1-7/16-18UNEF-2A	.375 (9.52)
CA3100KE28-†	1-3/4-18UNS-2A	.625 (15.88)	.078 (1.98)	2.688 (68.28)	.891 (22.63)	1.781 (45.24)	1.562 (39.67)	2.000 (50.80)	.177 (4.50)	1-7/16-18UNS-2A	.375 (9.52)
CA3100KE32-†	2-18UNS-2A	.625 (15.88)	.078 (1.98)	2.375 (60.32)	.891 (22.63)	2.031 (51.59)	1.750 (44.45)	2.250 (57.15)	.209 (5.31)	1-3/4-18UNS-2A	.437 (11.10)
CA3100KE36-†	2-1/4-16UNS-2A	.625 (15.88)	.094 (2.39)	2.438 (61.93)	.891 (22.63)	2.281 (57.94)	1.938 (49.23)	2.500 (63.50)	.209 (5.31)	2-18UNS-2A	.500 (12.70)

• Receptacles in size 10SL are available with pin inserts only.

* Add contact arrangements. See page A-127.

† Add contact type: P - pin; S - socket

Straight Plug

CA3106KE

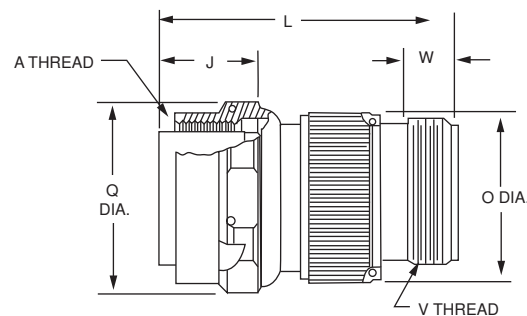
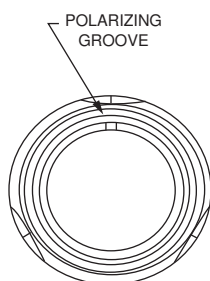

Part Number	A Thread	J	L	O	Q	V Thread	W
CA3106KE8S-†	1/2-28UNEF-2B	.531 (13.49)	2.000 (50.80)	.531 (13.49)	.828 (21.03)	1/2-28UNEF-2A	.375 (9.52)
CA3106KE10S-†	5/8-24UNEF-2B	.531 (13.49)	2.000 (50.80)	.687 (17.45)	.969 (24.62)	1/2-24UNEF-2A	.375 (9.52)
• CA3106KE10S-†	5/8-24UNEF-2B	.531 (13.49)	2.000 (50.80)	.781 (19.84)	.969 (24.62)	5/8-24UNEF-2A	.375 (9.52)
CA3106KE12S-†	3/4-20UNEF-2B	.531 (13.49)	2.000 (50.80)	.781 (19.84)	1.047 (26.59)	5/8-20UNEF-2A	.375 (9.52)
CA3106KE14S-†	7/8-20UNEF-2B	.531 (13.49)	2.000 (50.80)	.906 (23.01)	1.125 (28.58)	3/4-20UNEF-2A	.375 (9.52)
CA3106KE16S-†	1-20UNEF-2B	.531 (13.49)	2.000 (50.80)	1.031 (26.19)	1.250 (31.75)	7/8-20UNEF-2A	.375 (9.52)
CA3106KE16-†	1-20UNEF-2B	.719 (18.26)	2.188 (55.58)	1.031 (26.19)	1.250 (31.75)	7/8-20UNEF-2A	.375 (9.52)
CA3106KE18-†	1-1/8-18UNEF-2B	.719 (18.26)	2.250 (57.15)	1.156 (29.36)	1.344 (34.14)	1-20UNEF-2A	.375 (9.52)
CA3106KE20-†	1-1/4-18UNEF-2B	.719 (18.26)	2.313 (58.75)	1.344 (34.14)	1.484 (37.69)	1-3/16-18UNEF-2A	.375 (9.52)
CA3106KE22-†	1-3/8-18UNEF-2B	.719 (18.26)	2.313 (58.75)	1.406 (35.71)	1.609 (40.87)	1-3/16-18UNEF-2A	.375 (9.52)
CA3106KE24-†	1-1/2-18UNEF-2B	.719 (18.26)	2.313 (58.75)	1.625 (41.28)	1.734 (44.04)	1-7/16-18UNEF-2A	.375 (9.52)
CA3106KE28-†	1-3/4-18UNS-2B	.719 (18.26)	2.688 (68.28)	1.781 (45.24)	1.984 (50.39)	1-7/16-18UNEF-2A	.375 (9.52)
CA3106KE32-†	2-18UNS-2B	.719 (18.26)	2.375 (60.32)	2.031 (51.59)	2.234 (56.74)	1-3/4-18UNS-2A	.437 (11.10)
CA3106KE36-†	2-1/4-16UNS-2B	.719 (18.26)	2.438 (61.93)	2.281 (57.94)	2.484 (63.09)	2-18UNS-2A	.500 (12.70)

• Plugs in size 10SL are available with socket inserts only.

* Add contact arrangements. See page A-127.

† Add contact type: P - pin; S - socket

NOTE: Coupling nut has hex configuration on sizes 8S, 10S, 10SL, 12 and 24; knurled configuration on all others.



Dimensions shown in inches (mm)
Specifications and dimensions subject to change

www.ittcannon.com

Assembly Instructions

1. Disassemble the connector. See Figure 1 for component parts relationship for reassembly after wiring.
2. Remove ceramic retaining ring from contact by sliding the retaining ring back, compressing the bushing until the ring can be slipped away from the contact (Figure 2).
3. Crimp pin or socket contact to wire.
4. Slip endbell or ferrule retaining nut (whichever is used) over wire bundle (see Figure 3).
5. Slip ferrule over wire bundle (see Figure 3).
6. Push contact (pin or socket) thru rear of grommet and rear insulator. (Note that the contact is inserted into the end of the grommet that shows the layout identification.) Contact should extend sufficiently to

- accomplish Step 7.
7. After the wired contacts have been inserted thru the rear insulator and grommet, install the ceramic contact retaining ring (Figure 2). Slip on the small diameter of the contact (diameter B). Push the ceramic ring up and onto the larger diameter of the contact (diameter A). The ceramic ring should then be in place. The rubber bushing (which is already on the contact) compresses to allow this assembly, and also keeps the ceramic ring in place after assembly.
8. Set each contact individually in rear insulator (see Figure 4), pulling rear insulator so it is tight against the grommet.
9. Assemble front insulator onto engaging end of contacts.
10. Slide ferrule down wire bundle over grommet, making sure that grommet is lubricated per assembly drawing (see Figure 4).
11. Insert this assembly into shell or barrel (whichever is applicable) being careful to polarize correctly.
12. Slide endbell or ferrule retaining nut down wire bundle and screw onto shell/barrel. When properly assembled the layout identification will be visible.

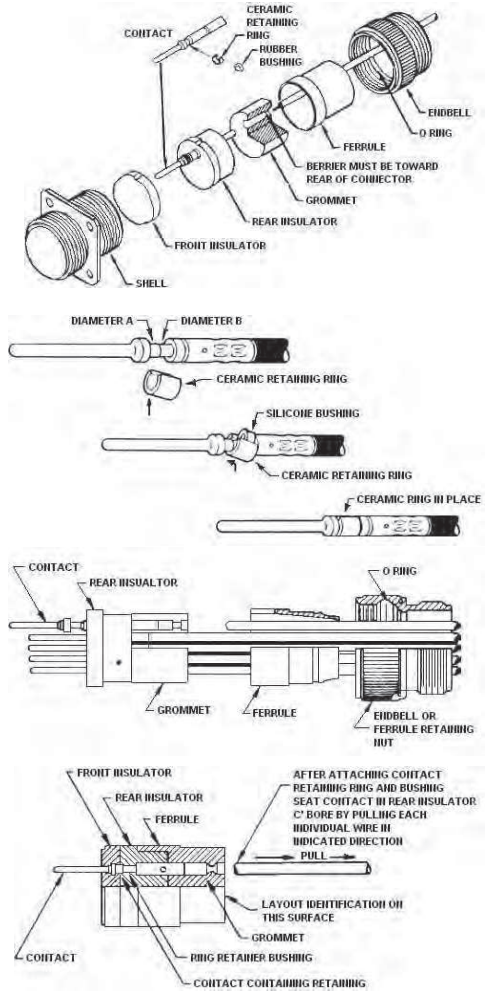

*Note: for CA-KE Assembly it is not necessary to remove the ceramic retaining ring used on size 16 and 12 contacts for CA-KE providing that the crimp tool M22520/1-01 is used with the TH118 turret. However, the formica ring must be removed if using the crimping tools.

When using the MS3191-1 (or CCT-1612) crimp tool with property locator, both the ceramic or formica retaining ring for sizes 16 and 12 contacts must be removed. For sizes 8, 4, and 0 contacts, the ceramic or formica retaining rings must be removed before crimping.

Contacts, Crimp Tools, Contact Part Numbers

Contacts and Crimp Tools

Contact Size	Part Number	Wire Accomm.	Crimp Tool	Locator	Crimp Head*	Contact Size	Kit Part Number
16 Pin/8S-16S	030-1133-000	16-18-20	M22520/1-01 or MS3191-1	TH118 Turret/L16-3191-2	—	16 Pin/8S-16S	038586-0000
16 Pin/12-36	030-1082-000	16-18-20	M22520/1-01 or MS3191-1	TH118 Turret/L16-3191-9	—	16 Pin/12-36	038588-0000
16 Socket/8S-16S	031-0731-000	16-18-20	M22520/1-01 or MS3191-1	TH118 Turret/L16-3191-2	—	16 Socket/8S-16S	038587-0000
16 Socket/12-36	031-0706-000	16-18-20	M22520/1-01 or MS3191-1	TH118 Turret/L16-3191-11	—	16 Socket/12-36	038589-0000
12 Pin	030-1134-000	12-14	M22520/1-01 or MS3191-1	TH118 Turret/L12-3191-5	—	12 Pin	038590-0000
12 Socket	031-0732-000	12-14	M22520/1-01 or MS3191-1	TH118 Turret/L12-3191-1	—	12 Socket	038591-0000
8 Pin	030-1135-000	8	CBT600B or CBT600	CCHP8-7	CCH8-1	8 Pin	038592-0000
8 Socket	031-0733-000	8	CBT600B or CBT600	CCHP8-7	CCH8-1	8 Socket	038593-0000
4 Pin	030-1212-000	4	CBT600B or CBT600	CCHP4-7	CCH4-1	4 Pin	038594-0000
4 Socket	031-0770-000	4	CBT600B or CBT600	CCHP4-7	CCH4-1	4 Socket	038595-0000
0 Pin	030-1734-000	0	6BT600B	CCHP0-7	CCH0-1	0 Pin	031-1176-000
0 Socket	031-0975-000	0	6BT600B	CCHP0-7	CCH0-1	0 Socket	031-1177-000

* Applicable for contact sizes 8, 4, and 0.

Dimensions shown in inches (mm)
Specifications and dimensions subject to change