



Chipsmall Limited consists of a professional team with an average of over 10 year of expertise in the distribution of electronic components. Based in Hongkong, we have already established firm and mutual-benefit business relationships with customers from,Europe,America and south Asia,supplying obsolete and hard-to-find components to meet their specific needs.

With the principle of "Quality Parts,Customers Priority,Honest Operation,and Considerate Service",our business mainly focus on the distribution of electronic components. Line cards we deal with include Microchip,ALPS,ROHM,Xilinx,Pulse,ON,Everlight and Freescale. Main products comprise IC,Modules,Potentiometer,IC Socket,Relay,Connector.Our parts cover such applications as commercial,industrial, and automotives areas.

We are looking forward to setting up business relationship with you and hope to provide you with the best service and solution. Let us make a better world for our industry!



Contact us

Tel: +86-755-8981 8866 Fax: +86-755-8427 6832

Email & Skype: info@chipsmall.com Web: www.chipsmall.com

Address: A1208, Overseas Decoration Building, #122 Zhenhua RD., Futian, Shenzhen, China



NOTES:

1. MATERIALS AND FINISHES:
 BODY, LOCK RING, LOCK WASHER &
 HEX-NUT - BRASS, NICKEL PLATING
 INSULATOR - PTFE, NATURAL
 CONTACTS - BeCu, GOLD PLATING
2. ELECTRICAL:
 A. IMPEDANCE: 75 OHM
 B. FREQUENCY RANGE: DC-12 GHz
 C. RETURN LOSS: -20 dB MAX. @ DC-6 GHz
 -15 dB MAX. @ 6-12 GHz
 D. DWV: 1500 VRMS

3. MECHANICAL:
 A. DURABILITY: 500 CYCLES MIN.
 B. TEMPERATURE RANGE: -65°C TO +165°C
 C. RECOMMENDED TORQUE: 30 IN-LBS
4. PACKAGING:
 A. QUANTITY: SINGLE PACK
 B. MARKING: BAG TO BE MARKED
 "AMPHENOL RF, 31-220N-75-12G AND DATE CODE"

THIRD ANGLE PROJ.

REVISIONS

REV	DESCRIPTION	DATE	ECN	APPR
A	RELEASE TO MFG.	04-May-18	8023	BMG

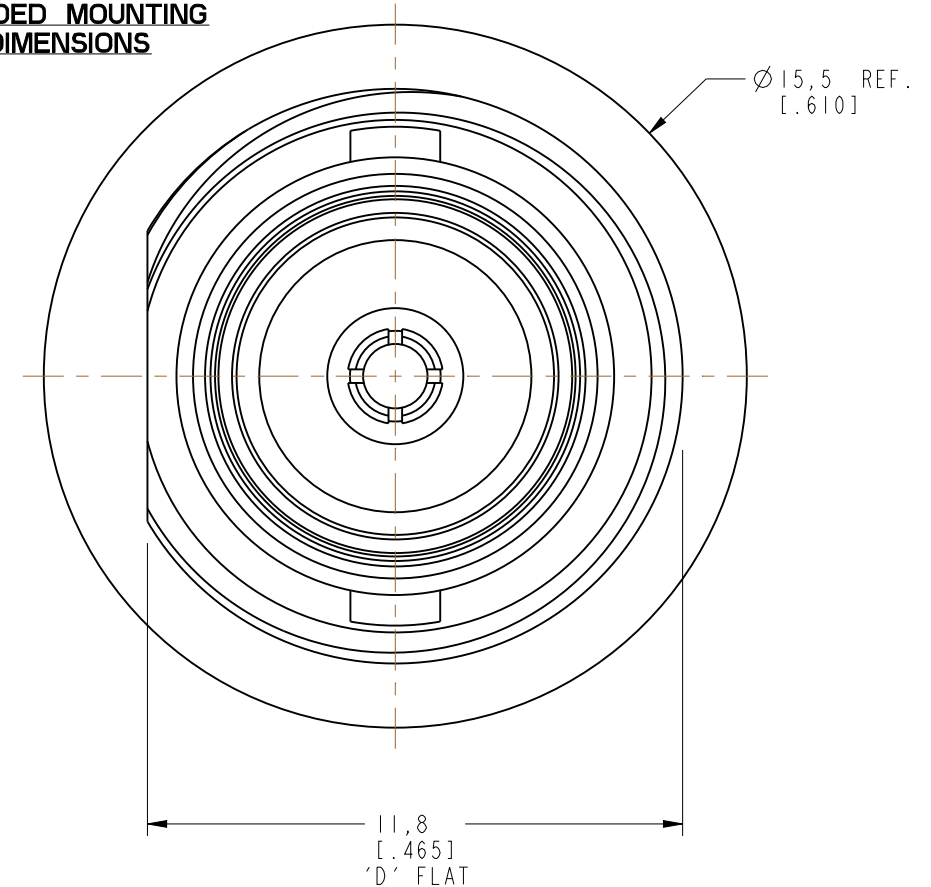
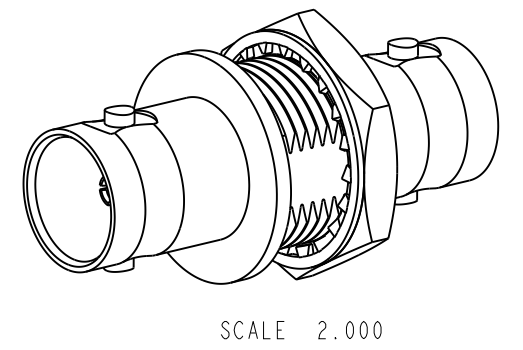
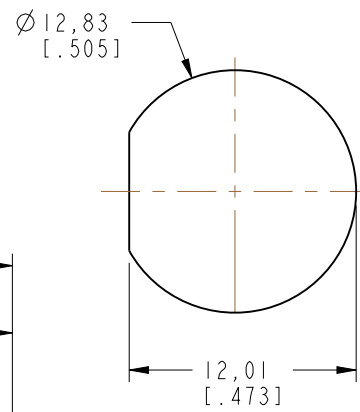
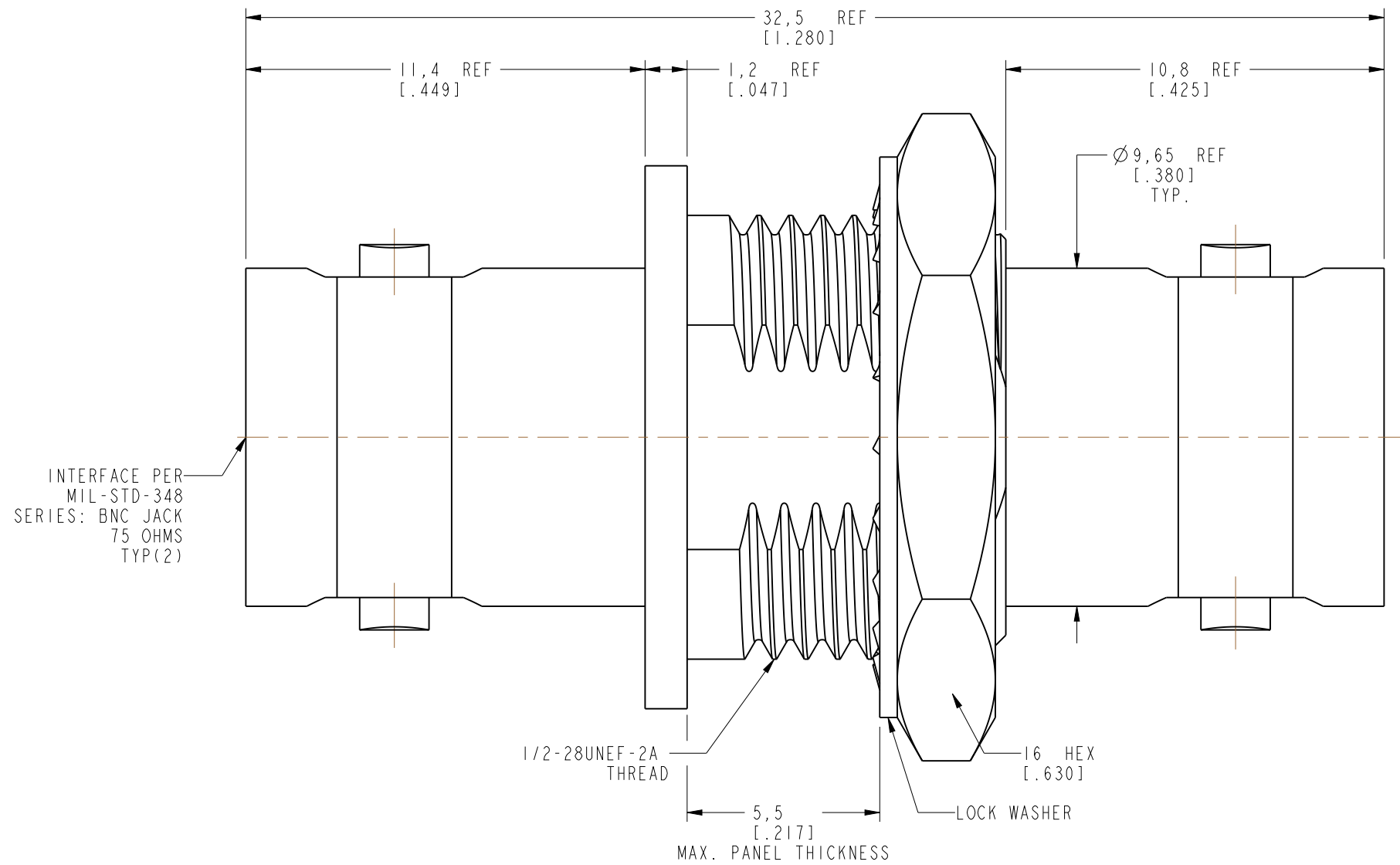

CUSTOMER OUTLINE DRAWING
 ALL OTHER SHEETS ARE FOR INTERNAL USE ONLY

UNLESS OTHERWISE SPECIFIED, DIMENSIONS ARE IN METRIC AND TOLERANCES ARE:
 <0.5mm ±0.05mm 0.5 - 6mm ±0.1mm 6 - 30mm ±0.2mm 30 - 120mm ±0.3mm ANGLES ±1°

NOTICE - These drawings, specifications, or other data (1) are, and remain the property of Amphenol corp. (2) must be returned upon request; and (3) are confidential and not to be disclosed to any person other than those to whom they are given by Amphenol Corp. the furnishing of these drawings, specifications, or other data by Amphenol Corp., or to any other person to anyone for any purpose is not to be regarded by implication or otherwise in any manner licensing, granting rights to permitting such holder or any other person to manufacture, use or sell any product, process or design, patented or otherwise, that may in any way be related to or disclosed by said drawings, specifications, or other data.

MATERIAL SEE NOTES	DRAWN LOKESH P	DATE 12-Sep-17
REFERENCE EAR# 7824	ENGINEER ANANDH G	DATE 12-Sep-17
REF:	APPROVED K. CAPOZZI	DATE 04-May-18
CONFIGURATION LEVEL: In Work	CAD FILE	
FINISH		

TITLE 75 OHM BNC STR BHD JACK TO JACK ADAPTER	SCALE: 6.0:1.0	SHEET 2 OF 2
DWG SIZE B	REV A	

Amphenol RF
www.amphenolrf.com
DRAWING NO. 31-220N-75-12G
ITEM NO. 31-220N-75-12G
PART NO. 31-220N-75-12G