



Chipsmall Limited consists of a professional team with an average of over 10 year of expertise in the distribution of electronic components. Based in Hongkong, we have already established firm and mutual-benefit business relationships with customers from,Europe,America and south Asia,supplying obsolete and hard-to-find components to meet their specific needs.

With the principle of “Quality Parts,Customers Priority,Honest Operation,and Considerate Service”,our business mainly focus on the distribution of electronic components. Line cards we deal with include Microchip,ALPS,ROHM,Xilinx,Pulse,ON,Everlight and Freescale. Main products comprise IC,Modules,Potentiometer,IC Socket,Relay,Connector.Our parts cover such applications as commercial,industrial, and automotives areas.

We are looking forward to setting up business relationship with you and hope to provide you with the best service and solution. Let us make a better world for our industry!



## Contact us

Tel: +86-755-8981 8866 Fax: +86-755-8427 6832

Email & Skype: info@chipsmall.com Web: www.chipsmall.com

Address: A1208, Overseas Decoration Building, #122 Zhenhua RD., Futian, Shenzhen, China



NOTES:

1. MATERIALS AND FINISHES:  
 BODY - ZINC DIE CAST, NICKEL PLATING  
 CONTACT - PHOSPHOR BRONZE, GOLD PLATING (.000003 THICK)  
 @ CONTACT AREA ONLY, TIN PLATING AT TAIL, NICKEL PLATED OVERALL  
 INSULATOR - POLYPROPYLENE  
 ROUND PIN - BRASS, TIN PLATING  
 GROUNDING TERMINAL - STEEL, TIN PLATING
2. ELECTRICAL:  
 A. IMPEDANCE: 50 OHM  
 B. FREQUENCY RANGE: DC - 1 GHz  
 C. DIELECTRIC WITHSTANDING VOLTAGE: 1500 VRMS, MIN.
3. MECHANICAL:  
 A. DURABILITY: 500 CYCLES MIN.  
 B. TEMPERATURE RANGE: -55° C TO 85° C
4. PACKAGING:  
 A. PACKAGED IN PACKING TRAYS  
 B. QUANTITY PER TRAY: 40
5. SEPERATELY SUPPLIED MOUNTING HARDWARE TO BE TIGHTENED TO 10 IN-LBS MIN/15 IN-LBS MAX WHEN ASSEMBLING TO PANEL

THIRD ANGLE PROJ.

REVISIONS				
REV	DESCRIPTION	DATE	ECO	APPR
A	RELEASE TO MFG	11/27/91	38657	DL/DR
L	SEE SHEET I	4/26/96	41291	CPM
M	SEE SHEET I	11/18/96	41643	CPM
N	PIN CHANGED	2/3/05	45258	CPM
P	UPDATED FORMAT AND NOMINAL ENVELOPE DIMENSIONS	9/10/12	49195	EW

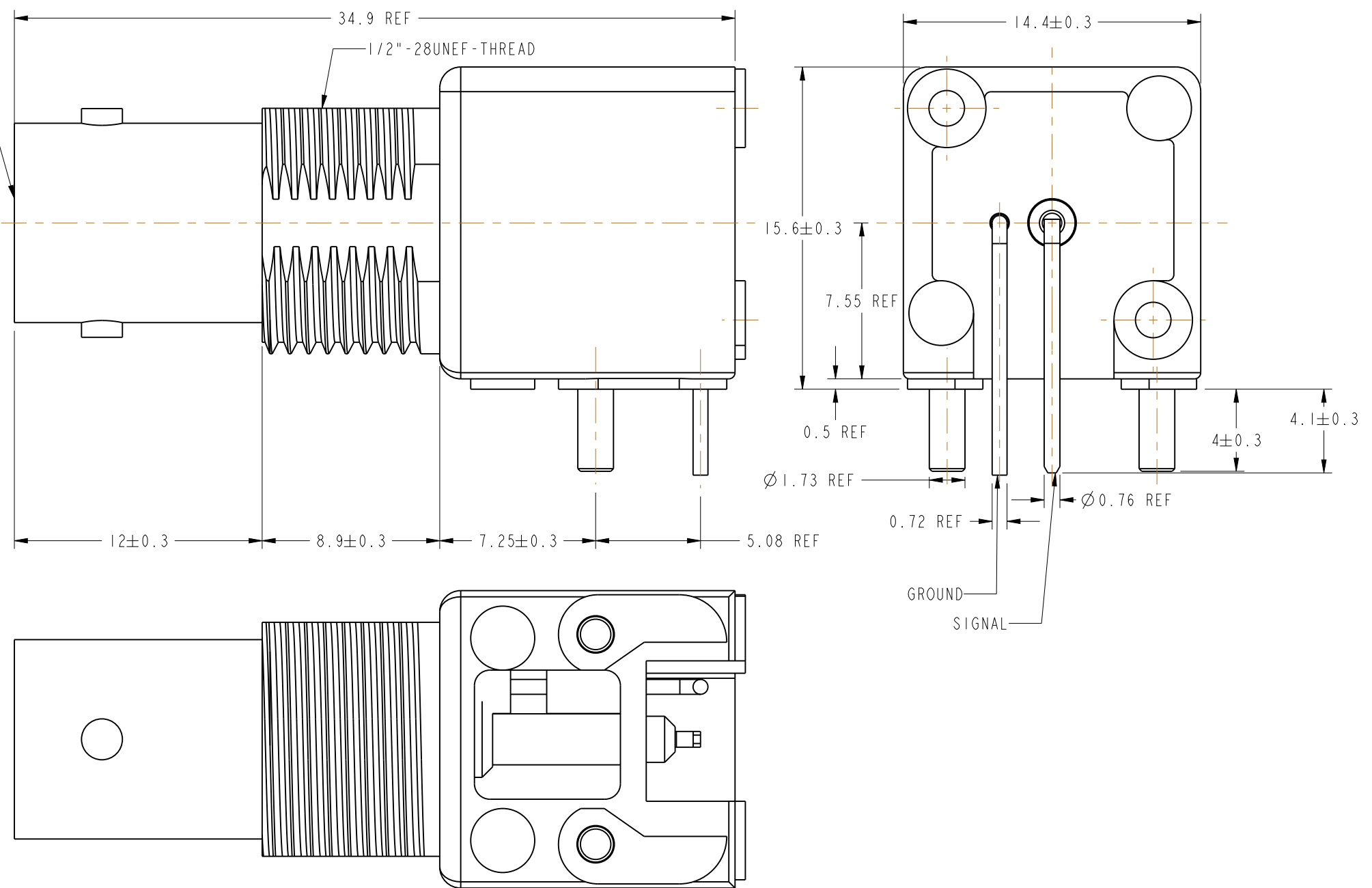
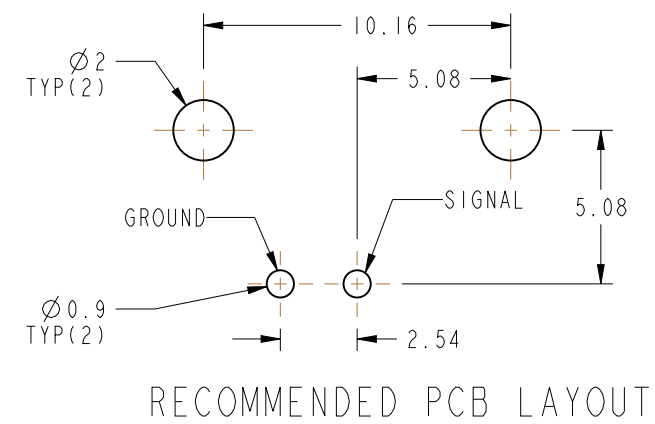
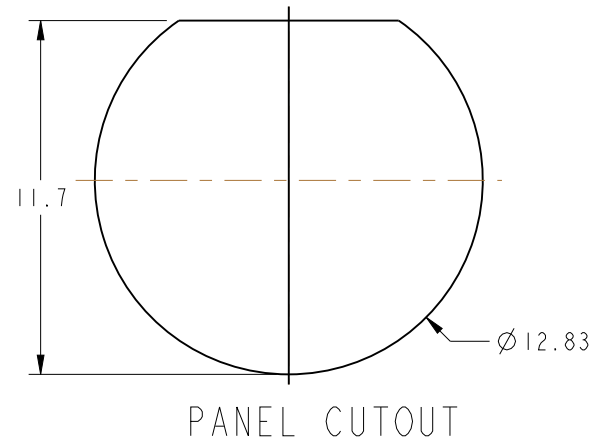
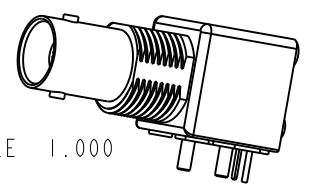

**CUSTOMER OUTLINE DRAWING**  
 ALL OTHER SHEETS ARE FOR INTERNAL USE ONLY

UNLESS OTHERWISE SPECIFIED, DIMENSIONS ARE IN METRIC AND TOLERANCES ARE: <0.5mm ± 0.05mm    0.5 - 6mm ± 0.1mm    6 - 30mm ± 0.2mm    30 - 120mm ± 0.3mm    ANGLES ± 1°	MATERIAL	DRAWN	DATE	TITLE 50 OHM BNC R/A JACK		Amphenol RF www.amphenolrf.com
		ERIC WANKOFF	27-Jun-12			
	REFERENCE	ENGINEER	DATE	SCALE: 4.0:1.0    SHEET 2 OF 2		DRAWING NO. 31-5640
	CONFIGURATION LEVEL:	D ROYCE	2/6/92			ITEM NO. 31-5640
FINISH	APPROVED	DATE	DWG SIZE	REV	PART NO. 31-5640	
	D ROYCE	2/6/92	B	I		
NOTICE - These drawings, specifications, or other data (1) are, and remain the property of Amphenol corp. (2) must be returned upon request; and (3) are confidential and not to be disclosed to any person other than those to whom they are given by Amphenol Corp. the finishing of these drawings, specifications, or other data by Amphenol Corp., or to any other person to anyone for any purpose is not to be regarded by implication or otherwise in any manner licensing, granting rights to permitting such holder or any other sperson to manufacture, use or sell any product, process or design, patented or otherwise, that may in any way be related to or disclosed by said drawings, specifications, or other data.		CAD FILE				