



Chipsmall Limited consists of a professional team with an average of over 10 year of expertise in the distribution of electronic components. Based in Hongkong, we have already established firm and mutual-benefit business relationships with customers from,Europe,America and south Asia,supplying obsolete and hard-to-find components to meet their specific needs.

With the principle of "Quality Parts,Customers Priority,Honest Operation,and Considerate Service",our business mainly focus on the distribution of electronic components. Line cards we deal with include Microchip,ALPS,ROHM,Xilinx,Pulse,ON,Everlight and Freescale. Main products comprise IC,Modules,Potentiometer,IC Socket,Relay,Connector.Our parts cover such applications as commercial,industrial, and automotives areas.

We are looking forward to setting up business relationship with you and hope to provide you with the best service and solution. Let us make a better world for our industry!



## Contact us

Tel: +86-755-8981 8866 Fax: +86-755-8427 6832

Email & Skype: info@chipsmall.com Web: www.chipsmall.com

Address: A1208, Overseas Decoration Building, #122 Zhenhua RD., Futian, Shenzhen, China



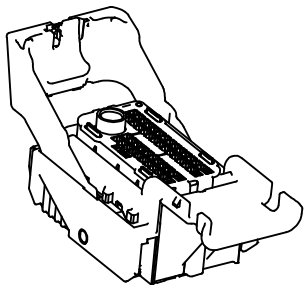

49 CKT  
SCALE 1.5:1

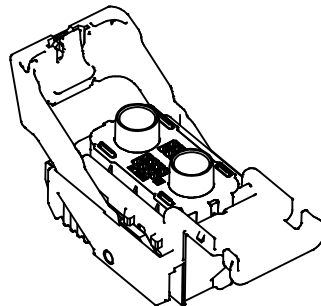
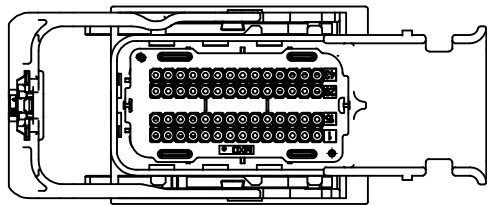

18 CKT  
SCALE 1.5:1

NOTES: UNLESS OTHERWISE SPECIFIED

1. MATERIAL:

- A. RESIN: SEE COMPONENT DRAWINGS
- B. COLOR: SEE TABLE
- C. MOLEX EDP #: SEE TABLE
- D. PART VOLUME: SEE COMPONENT DRAWINGS

2. DESIGN - GENERAL:

- A. THIS IS A 100% CAD GENERATED PART. THE CAD MATHEMATICAL DATA IS THE MASTER FOR THIS PART. FOR DIMENSIONAL OR ANY INFORMATION NOT SHOWN ON THIS DRAWING, ANALYZE THE CAD MODEL.
- B. TOLERANCES:
  - a. LINEAR XX ± 0.30  
XXX ± 0.10  
XXXX ± 0.10
  - b. ANGULAR X° ± 3.0°
- C. CORNERS SHOWN AS SHARP TO BE R 0.2 MAX.
- D. FOLLOWING PRODUCTION CODES TO BE PERMANENTLY MARKED & HUMAN READABLE TO A LETTER HEIGHT < 3mm.  
LINE #1: MATERIAL #: XXXXX-XXXX  
LINE #2: DATE CODE: JJYY (JULIAN DAY, LAST DIGIT OF YEAR)  
LINE #3: INSPECTION MACHINE CODE + SERIAL #: X\_XXXXX
- E-1. PARTS MUST BE FREE OF DISCOLORATION, SALT RESIDUE AND OTHER IMPERFECTIONS THAT AFFECT FIT OR FUNCTION.
- E-2. SCRATCHES OR DENTS NOT TO EXCEED 0.15mm IN DEPTH.
- F. CHANGES IN DESIGN FROM PART PREVIOUSLY APPROVED REQUIRES PRIOR ENGINEERING APPROVAL. THIS INCLUDES BUT IS NOT LIMITED TO DRAFT, MATERIAL OR PROCESSING.
- G. SHALL CONFORM TO THE FOLLOWING PACKAGING SPECIFICATION: PK-31300-019

3. DESIGN - MANUFACTURING:

- A. DRAFT TO BE WITHIN TOLERANCE.
- B. ALLOWABLE FLASH 0.2 MAX HIGH X 0.13 MAX THICK.
- C. ALLOWABLE PARTING LINE MISMATCH 0.2 MAX.
- D. EJECTOR PINS MARK TO BE FLUSH TO 0.25 MAX DEPRESSED.
- E. ALLOWABLE GATE VESTIGE TO BE FLUSH TO 0.25 MAX PROTRUSION.

4. SYSTEM REQUIREMENTS:

- WHEN TESTED TO SAE/USCAR-2 REV: 3, APRIL 2001, AND GMW #3191, AUGUST 22, 2000 (DRAFT).
- A. TPA (WITHOUT TERMINALS)
  - a. INSERTION FORCE FROM PRE-SET TO LOCK: >20
  - b. REMOVAL FORCE FROM PRE-SET: >20
- B. CPA
  - a. INSERTION FORCE FROM PRE-SET TO LOCK WITH CONNECTOR UN-MATED: >60N
  - b. REMOVAL FORCE FROM PRE-SET: >30N
- C. GROMMET CAP
  - a. REMOVAL FORCE FROM HOUSING WITH ENGAGED LATCHES: >110N
- D. MATE ASSIST LEVER
  - a. INADVERTENT ACTUATION FORCE DURING SHIPPING, HANDLING OR PRE-ASSEMBLY: >190N

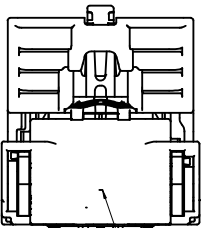

RECOMMENDED LOCATION FOR NOTE 2D

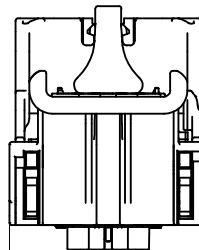
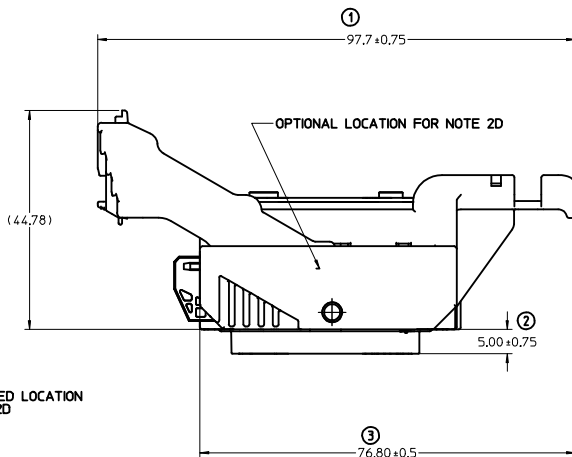

40.40 ± 0.50

BALLOONS ADDED ① ② ③ ④

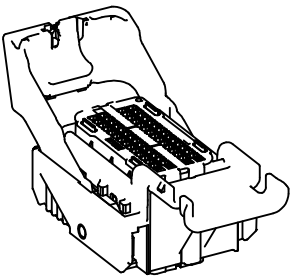

56 CKT  
SCALE 1.5:1

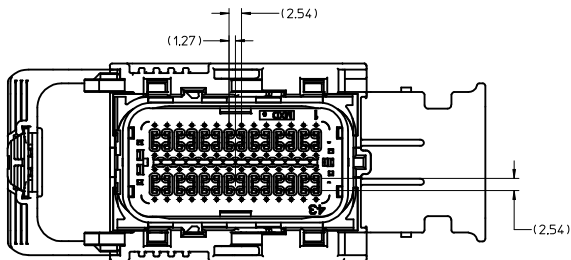

F38	ADDED NEW PART NO. 34576-7193
F37	ADDED NEW PART NO. 34576-7183
F36	RELEASE 18CKT FOR PV TOOL BUILD
F35	CHANGED PART NUMBER TO AVAILABLE
F34	ADDED NEW PART NO. 34576-7173
F33	ADDED NEW PART NO. 34576-7163
F32	ADDED NEW PART NO. 34576-7153 REVISE 34576-7123 PIN-OUT CONFIGURATION
F31	ADDED NEW PART NO. 34576-7133 34576-7143
F30	ADDED NEW PART NO. 34576-7123
F29	ADDED NEW PART NO. 34576-7113
F28	ADDED NEW PART NO. 34576-7103
F27	ADDED NEW PART NO. 34576-6993 34576-7003 34576-7013 34576-7023 34576-7033 34576-7043 34576-7053 34576-7063 34576-7073 34576-7083 34576-7093
F26	ADDED NEW PART NO. 34576-6983
F25	ADDED NEW PART NO. 34576-6973
F24	ADDED NEW PART NO. 34576-6963
F23	ADDED NEW PART NO. 34576-6953
F22	CHANGE WIRE DRESS OPTION FROM 0 TO 9 FOR PART NO. 34576-6943
F21	ADDED NEW PART NO. 34576-6943
F20	ADDED NEW PART NO. 34576-6933
F19	ADDED 18CKT FULLY PLUGGED PIN CONFIG PART NUMBERS
F18	ADDED 18CKT KEY G AND KEY H
F17	NEW PIN CONFIGURATION
F16	NEW PIN CONFIGURATION
F15	NEW PIN CONFIGURATION
F14	NEW PIN CONFIGURATION
F13	NEW PIN CONFIGURATION
F12	NEW PIN CONFIGURATION
REV	DESCRIPTION

ENTER DESCRIPTION DEC NO: UAU2013-1350 DRAWN BY: CHYD: APPR: KOSHY TJS REV	QUALITY SYMBOLS	GENERAL TOLERANCES (UNLESS SPECIFIED)	DIMENSION STYLE	SCALE	DESIGN UNITS	THIRD ANGLE PROJECTION
	▽=0	mm	MM ONLY	2:1	METRIC	☉
	▽=0	INCH				
	▽=0	ANGULAR ±				
	4 PLACES + --- + ---	DRAFT WHERE APPLICABLE MUST REMAIN WITHIN DIMENSIONS	DRAWN BY: SKRAJENDRANA 2011/01/25	TITLE	MX123 18/49/56 CKT HRNS CONN ASSY <b>molex</b>	
	3 PLACES + --- + ---		CHECKED BY: DATE		MATERIAL NO. SEE BOM TABLE DOCUMENT NO. SD-34576-001	
	2 PLACES + --- + ---		APPROVED BY: DATE		SHEET NO. 1 OF 15	
	1 PLACE + --- + ---				THIS DRAWING CONTAINS INFORMATION THAT IS PROPRIETARY TO MOLEX INCORPORATED AND SHOULD NOT BE USED WITHOUT WRITTEN PERMISSION	
	0 PLACE + --- + ---					

56 CKT

WIRE DRESS OPTION 0

HOUSING ONLY, SHOWN FOR CLARITY

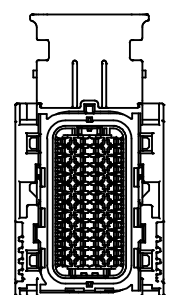
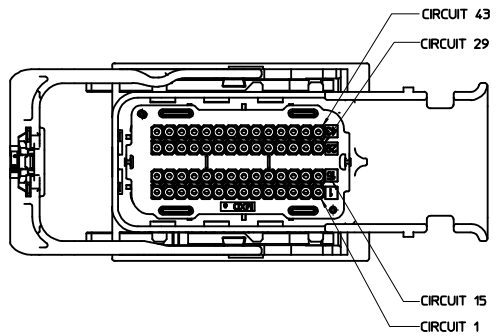

KEY G

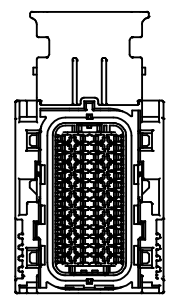

KEY H

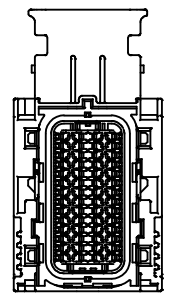

KEY J

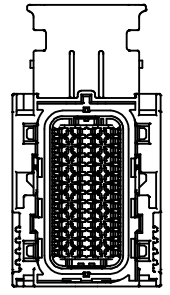

KEY K

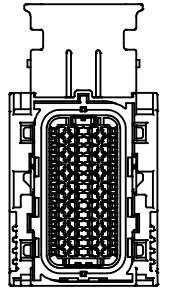

KEY L

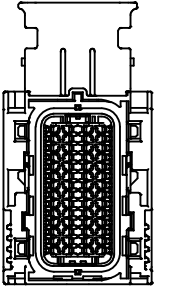

KEY M

WIRE DRESS OPTION 9

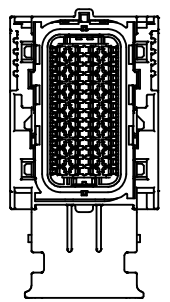
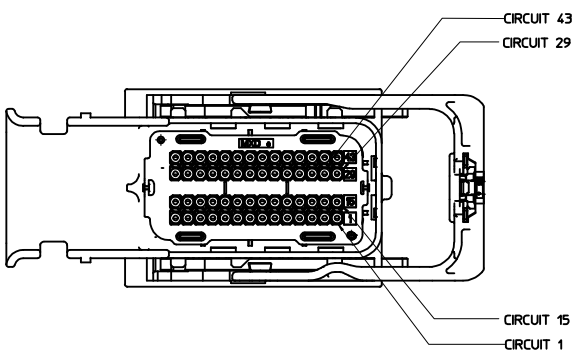

KEY G

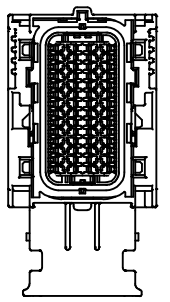

KEY H

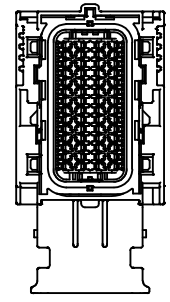

KEY J

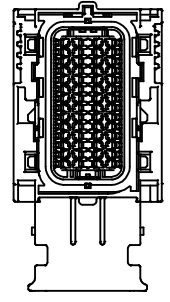

KEY K

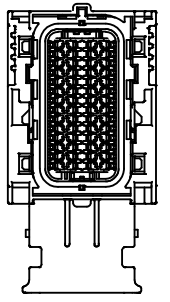

KEY L

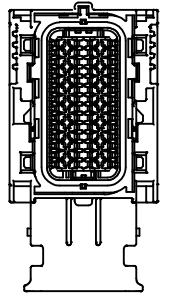

KEY M

ENTER DESCRIPTION EC NO: UAU2013-1350 DRAWN BY: TJJ CHKD: TJS APPR: IKOSHY 2013/02/26 2013/02/28	QUALITY SYMBOLS	GENERAL TOLERANCES (UNLESS SPECIFIED)		DIMENSION STYLE	SCALE	DESIGN UNITS	THIRD ANGLE PROJECTION
	▽=0	mm	INCH	MM ONLY	1:1	METRIC	
	▽=0	4 PLACES	+	+			
	▽=0	3 PLACES	+	+			
		ANGULAR ±---°		DRAWN BY: SKRAJENDRANA 2011/01/25		TITLE	
		DRAFT WHERE APPLICABLE MUST REMAIN WITHIN DIMENSIONS		CHECKED BY: DATE		MX123 18/49/56 CKT HRNS CONN ASSY	
				APPROVED BY: DATE		moLEX	
				MATERIAL NO.		DOCUMENT NO.	
				SEE BOM TABLE		SD-34576-001	
				SIZE D		THIS DRAWING CONTAINS INFORMATION THAT IS PROPRIETARY TO MOLEX INCORPORATED AND SHOULD NOT BE USED WITHOUT WRITTEN PERMISSION	
						SHEET NO. 2 OF 15	

49 CKT

WIRE DRESS OPTION 0

HOUSING ONLY, SHOWN FOR CLARITY

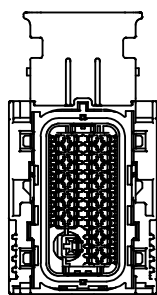
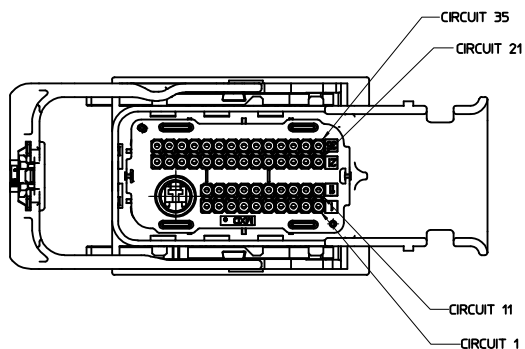

KEY A

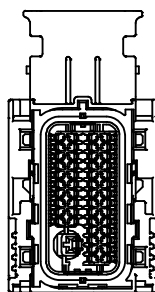

KEY B

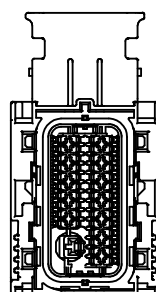

KEY C

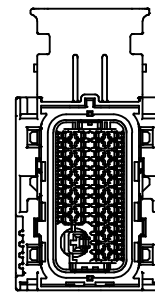

KEY D

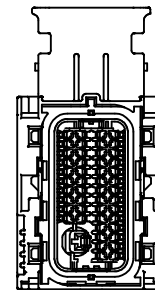

KEY E

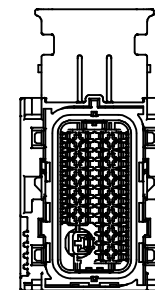

KEY F

WIRE DRESS OPTION 9

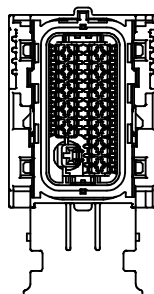
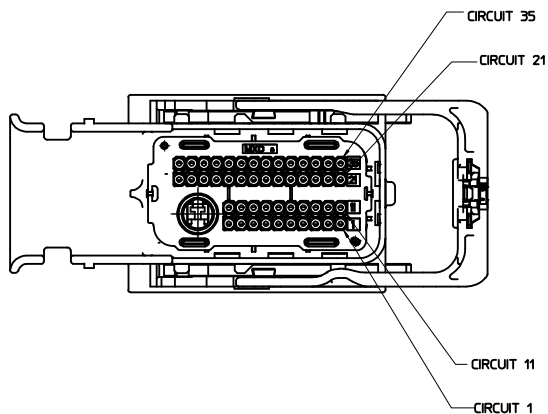

KEY A

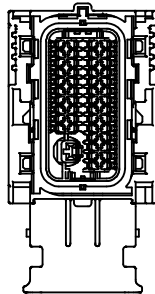

KEY B

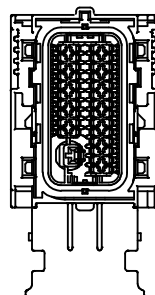

KEY C

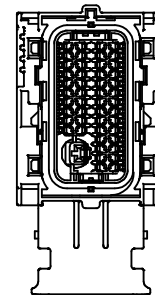

KEY D

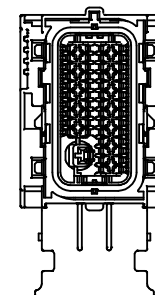

KEY E

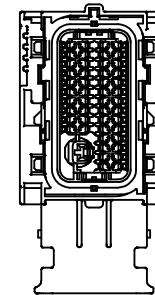

KEY F

ENTER DESCRIPTION EC NO: UAU2013-1350 DRAWN BY: DRINKATE CHKD: TJSB APPR: IKOSHY REV: 2013/02/26	QUALITY SYMBOLS	GENERAL TOLERANCES (UNLESS SPECIFIED)	DIMENSION STYLE	SCALE	DESIGN UNITS	THIRD ANGLE PROJECTION
	▽=0	mm INCH	MM ONLY	1.5:1	METRIC	
	▽=0	4 PLACES +---+---	DRAWN BY: SKRAJENDRANA	DATE: 2011/01/25	TITLE	MX123
	▽=0	3 PLACES +---+---	CHECKED BY:	DATE:	18/49/56 CKT	HRNS CONN ASSY
	2 PLACES +---+---	ANGULAR ±---°	APPROVED BY:	DATE:		
	1 PLACE +---+---	DRAFT WHERE APPLICABLE MUST REMAIN WITHIN DIMENSIONS	MATERIAL NO.	DOCUMENT NO.		
	0 PLACE +---+---		SEE BOM TABLE	SD-34576-001		SHEET NO. 3 OF 45
			THIS DRAWING CONTAINS INFORMATION THAT IS PROPRIETARY TO MOLEX INCORPORATED AND SHOULD NOT BE USED WITHOUT WRITTEN PERMISSION			

18 CKT

WIRE DRESS OPTION 0

HOUSING ONLY, SHOWN FOR CLARITY

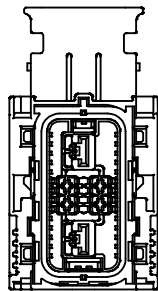
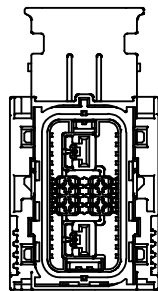
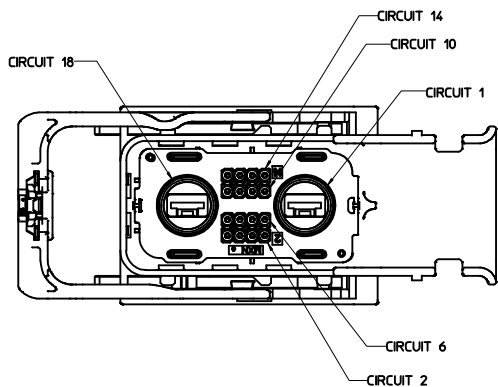

KEY G

KEY H

WIRE DRESS OPTION 9

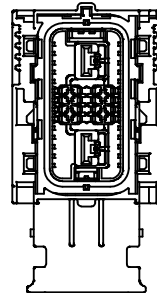
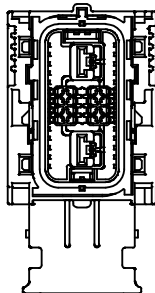
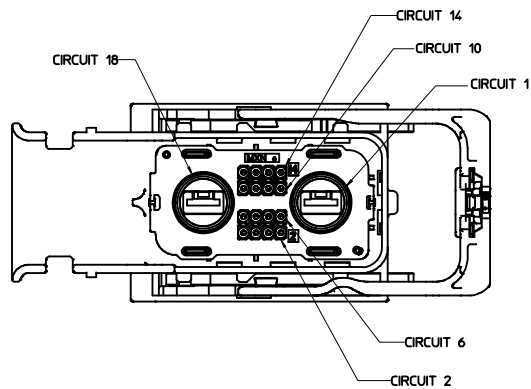

KEY G

KEY H

ENTER DESCRIPTION EC NO: UAU2013-1350 DRAWN BY: 2013/02/26 CHKD: APPR: IKOSHY T38 REV: 2013/02/28	QUALITY SYMBOLS	GENERAL TOLERANCES (UNLESS SPECIFIED)	DIMENSION STYLE	SCALE	DESIGN UNITS	THIRD ANGLE PROJECTION
	▽=0	4 PLACES ±---+---	mm INCH	2:1	METRIC	
	▽=0	3 PLACES ±---+---				
	▽=0	2 PLACES ±---+---				
		1 PLACE ±---+---				
		0 PLACE ±---+---				
		ANGULAR ±---°				
		DRAFT WHERE APPLICABLE MUST REMAIN WITHIN DIMENSIONS				
			SEE BOM TABLE			

MX123  
18/49/56 CKT  
HRNS CONN ASSY

**molex**

SD-34576-001

SHEET NO.  
4 OF 15

THIS DRAWING CONTAINS INFORMATION THAT IS PROPRIETARY TO MOLEX INCORPORATED AND SHOULD NOT BE USED WITHOUT WRITTEN PERMISSION



CKT SIZE	STATUS	MATERIAL #	PART / MATERIAL REVISION	WIRE DRESS OPTION	KEY OPTION	COLOR (TPA)	NUMBERS INDICATE CAVITIES OPEN FOR CIRCUITS																			
							1	2	3	4	5	6	7	8	9	10	11	12	13	14	15	16	17	18	19	20
49 CKT	ACTIVE	34576-0103	F	0	A	BLACK																				
	NOT TOOLED	34576-0203	F	0	B	ST GRY	48	47	46	45	44	43	42	41	40	39	38	37	36	35						
	NOT TOOLED	34576-0303	F	0	C	BLUE	34	33	32	31	30	29	28	27	26	25	24	23	22	21						
	NOT TOOLED	34576-0403	F	0	D	BROWN	49																			
	NOT TOOLED	34576-0503	F	0	E	GREEN																				
	NOT TOOLED	34576-0603	F	0	F	NATURAL	10	9	8	7	6	5	4	3	2	1										
56 CKT	AVAILABLE	34576-0703	F	0	G	BLUE																				
	ACTIVE	34576-0803	F	0	H	ST GRY	56	55	54	53	52	51	50	49	48	47	46	45	44	43						
	ACTIVE	34576-0903	F	0	J	BLACK	42	41	40	39	38	37	36	35	34	33	32	31	30	29						
	ACTIVE	34576-1003	F	0	K	BROWN	28	27	26	25	24	23	22	21	20	19	18	17	16	15						
	ACTIVE	34576-1103	F	0	L	GREEN	14	13	12	11	10	9	8	7	6	5	4	3	2	1						
	ACTIVE	34576-1203	F	0	M	NATURAL																				
49 CKT	ACTIVE	34576-1303	F	9	A	BLACK																				
	NOT TOOLED	34576-1403	F	9	B	ST GRY	48	47	46	45	44	43	42	41	40	39	38	37	36	35						
	NOT TOOLED	34576-1503	F	9	C	BLUE	34	33	32	31	30	29	28	27	26	25	24	23	22	21						
	NOT TOOLED	34576-1603	F	9	D	BROWN	49																			
	NOT TOOLED	34576-1703	F	9	E	GREEN																				
	NOT TOOLED	34576-1803	F	9	F	NATURAL	10	9	8	7	6	5	4	3	2	1										
56 CKT	AVAILABLE	34576-1903	F	9	G	BLUE																				
	ACTIVE	34576-2003	F	9	H	ST GRY	56	55	54	53	52	51	50	49	48	47	46	45	44	43						
	ACTIVE	34576-2103	F	9	J	BLACK	42	41	40	39	38	37	36	35	34	33	32	31	30	29						
	ACTIVE	34576-2203	F	9	K	BROWN	28	27	26	25	24	23	22	21	20	19	18	17	16	15						
	ACTIVE	34576-2303	F	9	L	GREEN	14	13	12	11	10	9	8	7	6	5	4	3	2	1						
	ACTIVE	34576-2403	F	9	M	NATURAL																				
18 CKT	PV TOOL REL.	34851-0007	A	0	G	BLUE	18																			
	PV TOOL REL.	34851-0008	A	0	H	ST GRY																				
18 CKT	PV TOOL REL.	34851-0019	A	9	G	BLUE	18																			
	PV TOOL REL.	34851-0020	A	9	H	ST GRY																				
	AVAILABLE	34576-2503	F	0	G	BLUE	56	55	54	53					49	48	47			44						
	AVAILABLE	34576-2603	F	0	G	BLUE					40				37	36	35	34	33							
	AVAILABLE	34576-2703	F	0	G	BLUE	13	12							9	7	6									

SEE NEXT PAGE FOR ADDITIONAL NUMBERS

ENTER DESCRIPTION ECC NO: UAU2013-1350 DRAWN BY: TJ DRW/NTYE 2013/02/26 CHKD: 2013/02/28 APPR: IKOSHY 2013/02/28		QUALITY SYMBOLS ∇=0 ∇=0 ∇=0	GENERAL TOLERANCES (UNLESS SPECIFIED) mm INCH 4 PLACES ± --- ± --- 3 PLACES ± --- ± --- 2 PLACES ± --- ± --- 1 PLACE ± --- ± --- 0 PLACE ± --- ± ---	DIMENSION STYLE MM ONLY	SCALE 2:1	DESIGN UNITS METRIC	THIRD ANGLE PROJECTION
DRAWN BY: SKRAJENDRANA 2011/01/25 CHECKED BY: DATE APPROVED BY: DATE				TITLE MX123 18/49/56 CKT HRNS CONN ASSY			
MATERIAL NO. SIZE				DOCUMENT NO. SHEET NO.			
SEE BOM TABLE				SD-34576-001 5 OF 15			

THIS DRAWING CONTAINS INFORMATION THAT IS PROPRIETARY TO MOLEX INCORPORATED AND SHOULD NOT BE USED WITHOUT WRITTEN PERMISSION

STATUS	GM PART #	MATERIAL #	PART/MATERIAL REVISION	WIRE DRESS OPTION	KEY OPTION	COLOR (TPA)	NUMBERS INDICATE CAVITIES OPEN FOR CIRCUITS																																												
AVAILABLE	NOT APPLICABLE	34576-2803	F	0	G	BLUE	<table border="1"> <tr><td>55</td><td>54</td><td>53</td><td>51</td><td>49</td><td>48</td><td>47</td><td>44</td></tr> <tr><td>40</td><td></td><td></td><td>37</td><td>36</td><td>35</td><td>34</td><td>33</td></tr> <tr><td>26</td><td></td><td></td><td></td><td></td><td></td><td>20</td><td>19 18</td></tr> <tr><td>13</td><td>12</td><td></td><td>9</td><td>7</td><td></td><td></td><td></td></tr> </table>	55	54	53	51	49	48	47	44	40			37	36	35	34	33	26						20	19 18	13	12		9	7															
55	54	53	51	49	48	47	44																																												
40			37	36	35	34	33																																												
26						20	19 18																																												
13	12		9	7																																															
AVAILABLE	NOT APPLICABLE	34576-2903	F	0	G	BLUE	<table border="1"> <tr><td>56</td><td>55</td><td>53</td><td></td><td>49</td><td>48</td><td>47</td><td>46</td><td>45</td><td>44</td></tr> <tr><td>40</td><td>39</td><td></td><td>37</td><td>36</td><td>35</td><td>34</td><td>33</td><td></td><td>30</td></tr> <tr><td></td><td>25</td><td></td><td></td><td></td><td></td><td>20</td><td>19</td><td>18</td><td></td></tr> <tr><td>13</td><td>12</td><td></td><td>9</td><td>7</td><td></td><td></td><td></td><td></td><td></td></tr> </table>	56	55	53		49	48	47	46	45	44	40	39		37	36	35	34	33		30		25					20	19	18		13	12		9	7									
56	55	53		49	48	47	46	45	44																																										
40	39		37	36	35	34	33		30																																										
	25					20	19	18																																											
13	12		9	7																																															
AVAILABLE	NOT APPLICABLE	34576-3003	F	0	G	BLUE	<table border="1"> <tr><td>56</td><td>55</td><td>54</td><td>53</td><td></td><td>49</td><td>48</td><td>47</td><td></td><td>44</td></tr> <tr><td></td><td>40</td><td></td><td></td><td>37</td><td>36</td><td>35</td><td>34</td><td>33</td><td>29</td></tr> <tr><td></td><td></td><td></td><td></td><td></td><td></td><td></td><td>20</td><td>19</td><td>18</td></tr> <tr><td>13</td><td>12</td><td></td><td>9</td><td>7</td><td>6</td><td></td><td></td><td></td><td>2</td></tr> </table>	56	55	54	53		49	48	47		44		40			37	36	35	34	33	29								20	19	18	13	12		9	7	6				2				
56	55	54	53		49	48	47		44																																										
	40			37	36	35	34	33	29																																										
							20	19	18																																										
13	12		9	7	6				2																																										
AVAILABLE	NOT APPLICABLE	34576-3103	F	0	G	BLUE	<table border="1"> <tr><td>56</td><td>55</td><td>54</td><td>53</td><td></td><td>49</td><td>48</td><td>47</td><td>46</td><td>45</td><td>44</td></tr> <tr><td></td><td>40</td><td>39</td><td></td><td>37</td><td>36</td><td>35</td><td>34</td><td>33</td><td></td><td></td></tr> <tr><td></td><td></td><td></td><td></td><td></td><td></td><td></td><td>20</td><td>19</td><td>18</td><td></td></tr> <tr><td>13</td><td>12</td><td></td><td>9</td><td>7</td><td></td><td></td><td></td><td></td><td></td><td></td></tr> </table>	56	55	54	53		49	48	47	46	45	44		40	39		37	36	35	34	33										20	19	18		13	12		9	7						
56	55	54	53		49	48	47	46	45	44																																									
	40	39		37	36	35	34	33																																											
							20	19	18																																										
13	12		9	7																																															
AVAILABLE	NOT APPLICABLE	34576-3203	F	0	G	BLUE	<table border="1"> <tr><td>55</td><td>54</td><td>53</td><td></td><td>49</td><td>48</td><td>47</td><td>46</td><td>44</td><td></td></tr> <tr><td></td><td>40</td><td></td><td></td><td>37</td><td>36</td><td>35</td><td>34</td><td>33</td><td>32</td><td>31</td></tr> <tr><td></td><td>26</td><td></td><td></td><td></td><td></td><td></td><td>20</td><td>19</td><td>18</td><td></td></tr> <tr><td>13</td><td>12</td><td></td><td>9</td><td>7</td><td></td><td></td><td></td><td></td><td></td><td></td></tr> </table>	55	54	53		49	48	47	46	44			40			37	36	35	34	33	32	31		26						20	19	18		13	12		9	7							
55	54	53		49	48	47	46	44																																											
	40			37	36	35	34	33	32	31																																									
	26						20	19	18																																										
13	12		9	7																																															
AVAILABLE	NOT APPLICABLE	34576-3303	F	0	G	BLUE	<table border="1"> <tr><td>56</td><td>55</td><td>54</td><td></td><td>49</td><td>48</td><td>47</td><td></td><td>44</td><td></td></tr> <tr><td></td><td>40</td><td></td><td></td><td>37</td><td>36</td><td>35</td><td>34</td><td>33</td><td></td></tr> <tr><td></td><td></td><td></td><td></td><td></td><td></td><td></td><td>20</td><td>19</td><td>18</td></tr> <tr><td>13</td><td>12</td><td></td><td>9</td><td>7</td><td>6</td><td></td><td></td><td></td><td></td></tr> </table>	56	55	54		49	48	47		44			40			37	36	35	34	33									20	19	18	13	12		9	7	6								
56	55	54		49	48	47		44																																											
	40			37	36	35	34	33																																											
							20	19	18																																										
13	12		9	7	6																																														
AVAILABLE	NOT APPLICABLE	34576-3403	F	0	G	BLUE	<table border="1"> <tr><td>55</td><td>54</td><td>53</td><td></td><td>49</td><td>48</td><td>47</td><td></td><td>44</td><td></td></tr> <tr><td></td><td>40</td><td>39</td><td></td><td>37</td><td>36</td><td>35</td><td>34</td><td>33</td><td></td></tr> <tr><td></td><td>26</td><td></td><td></td><td></td><td></td><td></td><td>20</td><td>19</td><td>18</td></tr> <tr><td>13</td><td>12</td><td></td><td>9</td><td>7</td><td></td><td></td><td></td><td></td><td></td></tr> </table>	55	54	53		49	48	47		44			40	39		37	36	35	34	33			26						20	19	18	13	12		9	7									
55	54	53		49	48	47		44																																											
	40	39		37	36	35	34	33																																											
	26						20	19	18																																										
13	12		9	7																																															
AVAILABLE	NOT APPLICABLE	34576-3503	F	0	G	BLUE	<table border="1"> <tr><td>56</td><td>55</td><td>53</td><td></td><td>49</td><td>48</td><td>47</td><td></td><td>44</td><td></td></tr> <tr><td></td><td>40</td><td></td><td></td><td>37</td><td>36</td><td>35</td><td>34</td><td>33</td><td></td></tr> <tr><td></td><td></td><td></td><td></td><td></td><td></td><td></td><td>20</td><td>19</td><td>18</td></tr> <tr><td>13</td><td>12</td><td></td><td>9</td><td>7</td><td>6</td><td></td><td></td><td></td><td>2</td></tr> </table>	56	55	53		49	48	47		44			40			37	36	35	34	33									20	19	18	13	12		9	7	6				2				
56	55	53		49	48	47		44																																											
	40			37	36	35	34	33																																											
							20	19	18																																										
13	12		9	7	6				2																																										

SEE NEXT PAGE FOR ADDITIONAL NUMBERS

<b>ENTER DESCRIPTION</b> EC NO: UAU2013-1350 DRAWN BY: T38 CHKD: T38 APPR: VKOSHY 2013/02/26 2013/02/28	QUALITY SYMBOLS ▽=0 ▽=0 ▽=0	GENERAL TOLERANCES (UNLESS SPECIFIED) mm INCH 4 PLACES ± --- ± --- 3 PLACES ± --- ± --- 2 PLACES ± --- ± --- 1 PLACE ± --- ± --- 0 PLACE ± --- ± ---	DIMENSION STYLE <b>MM ONLY</b>	SCALE <b>1:1</b>	DESIGN UNITS <b>METRIC</b>	THIRD ANGLE PROJECTION
	DRAWN BY: SKRAJENDRANA 2011/01/25 CHECKED BY: DATE		MATERIAL NO.		DOCUMENT NO.	
	APPROVED BY: DATE		SEE BOM TABLE		SD-34576-001	
	ANGULAR ± --- ° DRAFT WHERE APPLICABLE MUST REMAIN WITHIN DIMENSIONS		SHEET NO. 6 OF 45		TITLE MX123 18/49/56 CKT HRNS CONN ASSY <b>molex</b>	

STATUS	GM PART #	MATERIAL #	PART/MATERIAL REVISION	WIRE DRESS OPTION	KEY OPTION	COLOR (TPA)	NUMBERS INDICATE CAVITIES OPEN FOR CIRCUITS																																								
AVAILABLE	NOT APPLICABLE	34576-3603	F	0	G	BLUE	<table border="1"> <tr><td>55</td><td>54</td><td>53</td><td></td><td></td><td>49</td><td>48</td><td>47</td><td></td><td>44</td></tr> <tr><td>40</td><td></td><td></td><td>37</td><td>36</td><td>35</td><td>34</td><td>33</td><td></td><td></td></tr> <tr><td></td><td>26</td><td></td><td></td><td></td><td></td><td>20</td><td>19</td><td>18</td><td></td></tr> <tr><td>13</td><td>12</td><td></td><td>9</td><td>7</td><td></td><td></td><td></td><td></td><td></td></tr> </table>	55	54	53			49	48	47		44	40			37	36	35	34	33				26					20	19	18		13	12		9	7					
55	54	53			49	48	47		44																																						
40			37	36	35	34	33																																								
	26					20	19	18																																							
13	12		9	7																																											
AVAILABLE	NOT APPLICABLE	34576-3703	F	0	G	BLUE	<table border="1"> <tr><td>56</td><td>55</td><td>54</td><td>53</td><td>51</td><td>49</td><td>48</td><td>47</td><td></td><td>44</td></tr> <tr><td></td><td>40</td><td></td><td></td><td>37</td><td>36</td><td>35</td><td>34</td><td>33</td><td>29</td></tr> <tr><td></td><td></td><td></td><td></td><td></td><td></td><td>20</td><td>19</td><td>18</td><td>16</td></tr> <tr><td>13</td><td>12</td><td></td><td>9</td><td>7</td><td>6</td><td></td><td></td><td></td><td>2</td></tr> </table>	56	55	54	53	51	49	48	47		44		40			37	36	35	34	33	29							20	19	18	16	13	12		9	7	6				2
56	55	54	53	51	49	48	47		44																																						
	40			37	36	35	34	33	29																																						
						20	19	18	16																																						
13	12		9	7	6				2																																						
AVAILABLE	NOT APPLICABLE	34576-3803	F	0	G	BLUE	<table border="1"> <tr><td>56</td><td>54</td><td>53</td><td></td><td></td><td>49</td><td>47</td><td>46</td><td>44</td><td></td></tr> <tr><td></td><td>40</td><td>39</td><td>37</td><td>36</td><td>35</td><td>33</td><td>32</td><td>31</td><td>29</td></tr> <tr><td></td><td></td><td>25</td><td></td><td></td><td></td><td>20</td><td>19</td><td>18</td><td>15</td></tr> <tr><td>13</td><td>12</td><td></td><td>9</td><td>7</td><td></td><td></td><td></td><td></td><td>2</td></tr> </table>	56	54	53			49	47	46	44			40	39	37	36	35	33	32	31	29			25				20	19	18	15	13	12		9	7					2
56	54	53			49	47	46	44																																							
	40	39	37	36	35	33	32	31	29																																						
		25				20	19	18	15																																						
13	12		9	7					2																																						
AVAILABLE	NOT APPLICABLE	34576-3903	F	0	G	BLUE	<table border="1"> <tr><td>56</td><td>54</td><td>53</td><td></td><td></td><td>49</td><td>47</td><td></td><td>44</td><td></td></tr> <tr><td></td><td>40</td><td>39</td><td>37</td><td>36</td><td>35</td><td>33</td><td></td><td></td><td>29</td></tr> <tr><td></td><td></td><td>25</td><td></td><td></td><td></td><td>20</td><td>19</td><td>18</td><td>15</td></tr> <tr><td>13</td><td>12</td><td></td><td>9</td><td>7</td><td></td><td></td><td></td><td></td><td></td></tr> </table>	56	54	53			49	47		44			40	39	37	36	35	33			29			25				20	19	18	15	13	12		9	7					
56	54	53			49	47		44																																							
	40	39	37	36	35	33			29																																						
		25				20	19	18	15																																						
13	12		9	7																																											
AVAILABLE	NOT APPLICABLE	34576-4003	F	0	G	BLUE	<table border="1"> <tr><td>56</td><td>55</td><td>54</td><td>53</td><td></td><td>49</td><td>48</td><td>47</td><td>45</td><td>44</td></tr> <tr><td></td><td>40</td><td>39</td><td>37</td><td>36</td><td>35</td><td>34</td><td>33</td><td></td><td>29</td></tr> <tr><td></td><td></td><td>25</td><td></td><td></td><td></td><td>20</td><td>19</td><td>18</td><td>16</td></tr> <tr><td>13</td><td>12</td><td></td><td>9</td><td>7</td><td>6</td><td></td><td></td><td></td><td>1</td></tr> </table>	56	55	54	53		49	48	47	45	44		40	39	37	36	35	34	33		29			25				20	19	18	16	13	12		9	7	6				1
56	55	54	53		49	48	47	45	44																																						
	40	39	37	36	35	34	33		29																																						
		25				20	19	18	16																																						
13	12		9	7	6				1																																						
AVAILABLE	NOT APPLICABLE	34576-4103	F	0	G	BLUE	<table border="1"> <tr><td>56</td><td>55</td><td>54</td><td>53</td><td></td><td>49</td><td>48</td><td>47</td><td>46</td><td>44</td></tr> <tr><td></td><td>40</td><td>39</td><td>38</td><td>37</td><td>36</td><td>35</td><td>34</td><td>33</td><td>32</td></tr> <tr><td></td><td></td><td>25</td><td></td><td></td><td></td><td>20</td><td>19</td><td>18</td><td>16</td></tr> <tr><td>13</td><td>12</td><td></td><td>9</td><td>7</td><td></td><td></td><td></td><td></td><td></td></tr> </table>	56	55	54	53		49	48	47	46	44		40	39	38	37	36	35	34	33	32			25				20	19	18	16	13	12		9	7					
56	55	54	53		49	48	47	46	44																																						
	40	39	38	37	36	35	34	33	32																																						
		25				20	19	18	16																																						
13	12		9	7																																											
AVAILABLE	NOT APPLICABLE	34576-4203	F	0	G	BLUE	<table border="1"> <tr><td>56</td><td>55</td><td>54</td><td>53</td><td></td><td>49</td><td>48</td><td>47</td><td>45</td><td>44</td></tr> <tr><td></td><td>40</td><td>39</td><td>37</td><td>36</td><td>35</td><td>34</td><td>33</td><td></td><td></td></tr> <tr><td></td><td></td><td></td><td></td><td></td><td></td><td>20</td><td>19</td><td>18</td><td></td></tr> <tr><td>13</td><td>12</td><td></td><td>9</td><td>7</td><td></td><td></td><td></td><td></td><td></td></tr> </table>	56	55	54	53		49	48	47	45	44		40	39	37	36	35	34	33									20	19	18		13	12		9	7					
56	55	54	53		49	48	47	45	44																																						
	40	39	37	36	35	34	33																																								
						20	19	18																																							
13	12		9	7																																											
AVAILABLE	NOT APPLICABLE	34576-4303	F	0	G	BLUE	<table border="1"> <tr><td>56</td><td>55</td><td>54</td><td>53</td><td>51</td><td>49</td><td>48</td><td>47</td><td>45</td><td>44</td></tr> <tr><td>41</td><td>40</td><td>38</td><td>37</td><td>36</td><td>35</td><td>34</td><td>33</td><td></td><td>30</td></tr> <tr><td></td><td>26</td><td>25</td><td>24</td><td>22</td><td>21</td><td>20</td><td>19</td><td>17</td><td></td></tr> <tr><td>13</td><td>12</td><td></td><td>9</td><td>7</td><td></td><td></td><td>4</td><td>3</td><td>1</td></tr> </table>	56	55	54	53	51	49	48	47	45	44	41	40	38	37	36	35	34	33		30		26	25	24	22	21	20	19	17		13	12		9	7			4	3	1
56	55	54	53	51	49	48	47	45	44																																						
41	40	38	37	36	35	34	33		30																																						
	26	25	24	22	21	20	19	17																																							
13	12		9	7			4	3	1																																						

SEE NEXT PAGE FOR ADDITIONAL NUMBERS

<b>ENTER DESCRIPTION</b> EC NO: UAU2013-1350 DRAWN BY: CHYK APPR: IKOSHY 2013/02/26 2013/02/28 <b>FJ38</b>	QUALITY SYMBOLS ▽=0 ▽=0 ▽=0	GENERAL TOLERANCES (UNLESS SPECIFIED) <table border="1"> <tr><th></th><th>mm</th><th>INCH</th></tr> <tr><td>4 PLACES</td><td>±---</td><td>±---</td></tr> <tr><td>3 PLACES</td><td>±---</td><td>±---</td></tr> <tr><td>2 PLACES</td><td>±---</td><td>±---</td></tr> <tr><td>1 PLACE</td><td>±---</td><td>±---</td></tr> <tr><td>0 PLACE</td><td>±---</td><td>±---</td></tr> </table>		mm	INCH	4 PLACES	±---	±---	3 PLACES	±---	±---	2 PLACES	±---	±---	1 PLACE	±---	±---	0 PLACE	±---	±---	DIMENSION STYLE <b>MM ONLY</b>	SCALE <b>1:1</b>	DESIGN UNITS <b>METRIC</b>	THIRD ANGLE PROJECTION
		mm	INCH																					
	4 PLACES	±---	±---																					
	3 PLACES	±---	±---																					
2 PLACES	±---	±---																						
1 PLACE	±---	±---																						
0 PLACE	±---	±---																						
DRAWN BY: SKRAJENDRANA DATE: 2011/01/25	CHECKED BY:	DATE:	TITLE <b>MX123 18/49/56 CKT HRNS CONN ASSY</b>	MATERIAL NO.	DOCUMENT NO.	SHEET NO.																		
APPROVED BY:	DATE:	ANGULAR ±---°	SEE BOM TABLE	SD-34576-001	7 OF 15																			
THIS DRAWING CONTAINS INFORMATION THAT IS PROPRIETARY TO MOLEX INCORPORATED AND SHOULD NOT BE USED WITHOUT WRITTEN PERMISSION																								



34576

STATUS	GM PART #	MATERIAL #	PART / MATERIAL REVISION	WIRE DRESS OPTION	KEY OPTION	COLOR (TPA)	NUMBERS INDICATE CAVITIES OPEN FOR CIRCUITS																																																
AVAILABLE	NOT APPLICABLE	34576-4403	F	0	G	BLUE	<table border="1"> <tr><td>56</td><td>55</td><td>54</td><td>53</td><td></td><td></td><td>49</td><td>48</td><td>47</td><td>46</td><td>44</td></tr> <tr><td></td><td></td><td>40</td><td>39</td><td>37</td><td>36</td><td>35</td><td>34</td><td>33</td><td>32</td><td>31</td><td>29</td></tr> <tr><td></td><td></td><td></td><td>25</td><td></td><td></td><td></td><td>20</td><td>19</td><td>18</td><td>16</td><td></td></tr> <tr><td></td><td></td><td>12</td><td></td><td></td><td>9</td><td>7</td><td></td><td></td><td></td><td></td><td></td></tr> </table>	56	55	54	53			49	48	47	46	44			40	39	37	36	35	34	33	32	31	29				25				20	19	18	16				12			9	7						
56	55	54	53			49	48	47	46	44																																													
		40	39	37	36	35	34	33	32	31	29																																												
			25				20	19	18	16																																													
		12			9	7																																																	
AVAILABLE	NOT APPLICABLE	34576-4503	F	0	G	BLUE	<table border="1"> <tr><td>56</td><td>55</td><td>54</td><td>53</td><td></td><td></td><td>49</td><td>48</td><td>47</td><td>46</td><td>44</td></tr> <tr><td></td><td></td><td>40</td><td>39</td><td>37</td><td>36</td><td>35</td><td>34</td><td>33</td><td>32</td><td>31</td><td>30</td></tr> <tr><td></td><td></td><td></td><td>25</td><td>24</td><td></td><td>22</td><td>21</td><td>20</td><td>19</td><td>18</td><td>16</td></tr> <tr><td></td><td></td><td>13</td><td>12</td><td></td><td>9</td><td>7</td><td></td><td></td><td>4</td><td>2</td><td>1</td></tr> </table>	56	55	54	53			49	48	47	46	44			40	39	37	36	35	34	33	32	31	30				25	24		22	21	20	19	18	16			13	12		9	7			4	2	1	
56	55	54	53			49	48	47	46	44																																													
		40	39	37	36	35	34	33	32	31	30																																												
			25	24		22	21	20	19	18	16																																												
		13	12		9	7			4	2	1																																												
AVAILABLE	NOT APPLICABLE	34576-4603	F	0	G	BLUE	<table border="1"> <tr><td>56</td><td>55</td><td>54</td><td>53</td><td></td><td></td><td>49</td><td>48</td><td>47</td><td>46</td><td>44</td></tr> <tr><td></td><td></td><td>40</td><td>39</td><td>37</td><td>36</td><td>35</td><td>34</td><td>33</td><td>32</td><td>31</td><td>29</td></tr> <tr><td></td><td></td><td></td><td>25</td><td></td><td></td><td></td><td>20</td><td>19</td><td>18</td><td>16</td><td></td></tr> <tr><td></td><td></td><td>13</td><td>12</td><td></td><td>9</td><td>7</td><td></td><td></td><td></td><td></td><td></td></tr> </table>	56	55	54	53			49	48	47	46	44			40	39	37	36	35	34	33	32	31	29				25				20	19	18	16				13	12		9	7						
56	55	54	53			49	48	47	46	44																																													
		40	39	37	36	35	34	33	32	31	29																																												
			25				20	19	18	16																																													
		13	12		9	7																																																	
AVAILABLE	NOT APPLICABLE	34576-4703	F	0	G	BLUE	<table border="1"> <tr><td>56</td><td>55</td><td>54</td><td>53</td><td>51</td><td></td><td>49</td><td>48</td><td>47</td><td></td><td>44</td></tr> <tr><td></td><td></td><td>40</td><td>39</td><td>37</td><td>36</td><td>35</td><td>34</td><td>33</td><td></td><td>30</td></tr> <tr><td></td><td></td><td></td><td>25</td><td></td><td>22</td><td>21</td><td>20</td><td>19</td><td>18</td><td>16</td><td>15</td></tr> <tr><td></td><td></td><td>13</td><td>12</td><td></td><td>9</td><td>7</td><td></td><td></td><td>4</td><td>2</td><td>1</td></tr> </table>	56	55	54	53	51		49	48	47		44			40	39	37	36	35	34	33		30				25		22	21	20	19	18	16	15			13	12		9	7			4	2	1		
56	55	54	53	51		49	48	47		44																																													
		40	39	37	36	35	34	33		30																																													
			25		22	21	20	19	18	16	15																																												
		13	12		9	7			4	2	1																																												
AVAILABLE	NOT APPLICABLE	34576-4803	F	0	G	BLUE	<table border="1"> <tr><td></td><td>55</td><td>54</td><td>53</td><td>51</td><td></td><td>49</td><td>48</td><td>47</td><td></td><td>44</td></tr> <tr><td></td><td></td><td>40</td><td>39</td><td>37</td><td>36</td><td>35</td><td>34</td><td>33</td><td></td><td>29</td></tr> <tr><td></td><td></td><td></td><td>26</td><td></td><td></td><td></td><td>20</td><td>19</td><td>18</td><td>16</td><td>15</td></tr> <tr><td></td><td></td><td>13</td><td>12</td><td></td><td>9</td><td>7</td><td></td><td></td><td>4</td><td>2</td><td></td></tr> </table>		55	54	53	51		49	48	47		44			40	39	37	36	35	34	33		29				26				20	19	18	16	15			13	12		9	7			4	2			
	55	54	53	51		49	48	47		44																																													
		40	39	37	36	35	34	33		29																																													
			26				20	19	18	16	15																																												
		13	12		9	7			4	2																																													
ACTIVE	NOT APPLICABLE	34576-4903	F	9	G	BLUE	<table border="1"> <tr><td></td><td>55</td><td>54</td><td>53</td><td></td><td></td><td>49</td><td>48</td><td>47</td><td>46</td><td>44</td></tr> <tr><td></td><td></td><td>40</td><td></td><td></td><td>37</td><td>36</td><td>35</td><td>34</td><td>33</td><td>32</td><td>31</td></tr> <tr><td></td><td></td><td></td><td>26</td><td></td><td></td><td></td><td>20</td><td>19</td><td>18</td><td></td><td></td></tr> <tr><td></td><td></td><td>13</td><td>12</td><td></td><td>9</td><td>7</td><td></td><td></td><td></td><td></td><td></td></tr> </table>		55	54	53			49	48	47	46	44			40			37	36	35	34	33	32	31				26				20	19	18					13	12		9	7						
	55	54	53			49	48	47	46	44																																													
		40			37	36	35	34	33	32	31																																												
			26				20	19	18																																														
		13	12		9	7																																																	
AVAILABLE	NOT APPLICABLE	34576-5003	F	0	G	BLUE	<table border="1"> <tr><td></td><td>55</td><td>54</td><td>53</td><td></td><td></td><td>49</td><td>48</td><td>47</td><td></td><td>45</td><td>44</td></tr> <tr><td></td><td></td><td>40</td><td></td><td></td><td>37</td><td>36</td><td>35</td><td>34</td><td>33</td><td></td><td></td></tr> <tr><td></td><td></td><td></td><td>26</td><td></td><td></td><td></td><td>20</td><td>19</td><td>18</td><td></td><td></td></tr> <tr><td></td><td></td><td>13</td><td>12</td><td></td><td>9</td><td>7</td><td></td><td></td><td></td><td></td><td></td></tr> </table>		55	54	53			49	48	47		45	44			40			37	36	35	34	33						26				20	19	18					13	12		9	7					
	55	54	53			49	48	47		45	44																																												
		40			37	36	35	34	33																																														
			26				20	19	18																																														
		13	12		9	7																																																	
AVAILABLE	NOT APPLICABLE	34576-5103	F	0	G	BLUE	<table border="1"> <tr><td></td><td>55</td><td>54</td><td>53</td><td>51</td><td></td><td>49</td><td>48</td><td>47</td><td></td><td>44</td></tr> <tr><td></td><td></td><td>40</td><td></td><td>37</td><td>36</td><td>35</td><td>34</td><td>33</td><td></td><td>29</td></tr> <tr><td></td><td></td><td></td><td>26</td><td>24</td><td></td><td></td><td>20</td><td>19</td><td>18</td><td>16</td><td>15</td></tr> <tr><td></td><td></td><td>13</td><td>12</td><td></td><td>9</td><td>7</td><td></td><td></td><td>4</td><td>2</td><td></td></tr> </table>		55	54	53	51		49	48	47		44			40		37	36	35	34	33		29				26	24			20	19	18	16	15			13	12		9	7			4	2			
	55	54	53	51		49	48	47		44																																													
		40		37	36	35	34	33		29																																													
			26	24			20	19	18	16	15																																												
		13	12		9	7			4	2																																													

ENTER DESCRIPTION EC NO: VAAU2013-1350 DRAWN BY: 2013/02/26 CHKD: APPR: VIOSHY 2013/02/28 REV:	QUALITY SYMBOLS	GENERAL TOLERANCES (UNLESS SPECIFIED)	DIMENSION STYLE	SCALE	DESIGN UNITS	THIRD ANGLE PROJECTION	
	∇=0 ∇=0 ∇=0	4 PLACES +---+ 3 PLACES +---+ 2 PLACES +---+ 1 PLACE +---+ 0 PLACE +---+	mm    INCH +---+    +---+ +---+    +---+ +---+    +---+ +---+    +---+ +---+    +---+	MM ONLY DRAWN BY: SKRAJENDRANA 2011/01/25 CHECKED BY: DATE APPROVED BY: DATE	1:1	METRIC	MX123 18/49/56 CKT HRNS CONN ASSY <b>molex</b>
	ANGULAR ± DRAFT WHERE APPLICABLE MUST REMAIN WITHIN DIMENSIONS	SEE BOM TABLE SIZE D	MATERIAL NO.	DOCUMENT NO.	SHEET NO.		
				SD-34576-001	8 OF 15	THIS DRAWING CONTAINS INFORMATION THAT IS PROPRIETARY TO MOLEX INCORPORATED AND SHOULD NOT BE USED WITHOUT WRITTEN PERMISSION	

STATUS	GM PART #	MATERIAL #	PART/MATERIAL REVISION	WIRE DRESS OPTION	KEY OPTION	COLOR (TPA)	NUMBERS INDICATE CAVITIES OPEN FOR CIRCUITS																																																												
AVAILABLE	NOT APPLICABLE	34576-5203	F	0	G	BLUE	<table border="1"> <tr><td>56</td><td>55</td><td>54</td><td>53</td><td></td><td></td><td>49</td><td>48</td><td>47</td><td></td><td>44</td></tr> <tr><td></td><td>40</td><td>39</td><td></td><td>37</td><td>36</td><td>35</td><td>34</td><td>33</td><td></td><td>29</td></tr> <tr><td></td><td></td><td></td><td></td><td></td><td></td><td></td><td>20</td><td>19</td><td>18</td><td>15</td></tr> <tr><td></td><td>13</td><td>12</td><td></td><td></td><td>9</td><td>7</td><td></td><td></td><td></td><td></td></tr> </table>	56	55	54	53			49	48	47		44		40	39		37	36	35	34	33		29								20	19	18	15		13	12			9	7																				
56	55	54	53			49	48	47		44																																																									
	40	39		37	36	35	34	33		29																																																									
							20	19	18	15																																																									
	13	12			9	7																																																													
AVAILABLE	NOT APPLICABLE	34576-5403	F	0	G	BLUE	<table border="1"> <tr><td></td><td>55</td><td></td><td>53</td><td></td><td>51</td><td>49</td><td>48</td><td>47</td><td></td><td>44</td></tr> <tr><td></td><td></td><td>40</td><td>39</td><td></td><td>37</td><td>36</td><td>35</td><td>34</td><td>33</td><td>30</td></tr> <tr><td></td><td></td><td>26</td><td>25</td><td></td><td></td><td>22</td><td>21</td><td>20</td><td>19</td><td>18</td></tr> <tr><td></td><td>13</td><td>12</td><td></td><td></td><td>9</td><td>7</td><td></td><td>4</td><td></td><td>2</td></tr> </table>		55		53		51	49	48	47		44			40	39		37	36	35	34	33	30			26	25			22	21	20	19	18		13	12			9	7		4		2																
	55		53		51	49	48	47		44																																																									
		40	39		37	36	35	34	33	30																																																									
		26	25			22	21	20	19	18																																																									
	13	12			9	7		4		2																																																									
AVAILABLE	NOT APPLICABLE	34576-5503	F	0	G	BLUE	<table border="1"> <tr><td>56</td><td>55</td><td></td><td>53</td><td></td><td>51</td><td>49</td><td>48</td><td>47</td><td></td><td>44</td></tr> <tr><td></td><td></td><td>40</td><td>39</td><td></td><td>37</td><td>36</td><td>35</td><td>34</td><td>33</td><td>30</td></tr> <tr><td></td><td></td><td></td><td>25</td><td></td><td></td><td>22</td><td>21</td><td>20</td><td>19</td><td>18</td></tr> <tr><td></td><td>13</td><td>12</td><td></td><td></td><td>9</td><td>7</td><td></td><td></td><td>4</td><td>2</td></tr> </table>	56	55		53		51	49	48	47		44			40	39		37	36	35	34	33	30				25			22	21	20	19	18		13	12			9	7			4	2																
56	55		53		51	49	48	47		44																																																									
		40	39		37	36	35	34	33	30																																																									
			25			22	21	20	19	18																																																									
	13	12			9	7			4	2																																																									
AVAILABLE	NOT APPLICABLE	34576-5603	F	0	G	BLUE	<table border="1"> <tr><td>56</td><td>55</td><td></td><td>53</td><td></td><td></td><td>49</td><td>48</td><td>47</td><td>46</td><td>44</td></tr> <tr><td></td><td></td><td>40</td><td>39</td><td></td><td>37</td><td>36</td><td>35</td><td>34</td><td>33</td><td>31</td></tr> <tr><td></td><td></td><td></td><td>25</td><td></td><td></td><td>22</td><td>21</td><td>20</td><td>19</td><td>18</td></tr> <tr><td></td><td>13</td><td>12</td><td></td><td></td><td>9</td><td>7</td><td></td><td></td><td>4</td><td>2</td></tr> </table>	56	55		53			49	48	47	46	44			40	39		37	36	35	34	33	31				25			22	21	20	19	18		13	12			9	7			4	2																
56	55		53			49	48	47	46	44																																																									
		40	39		37	36	35	34	33	31																																																									
			25			22	21	20	19	18																																																									
	13	12			9	7			4	2																																																									
AVAILABLE	NOT APPLICABLE	34576-5703	F	0	G	BLUE	<table border="1"> <tr><td></td><td>55</td><td></td><td>53</td><td></td><td></td><td>49</td><td>48</td><td>47</td><td>46</td><td>44</td></tr> <tr><td></td><td></td><td>40</td><td>39</td><td></td><td>37</td><td>36</td><td>35</td><td>34</td><td>33</td><td>31</td></tr> <tr><td></td><td></td><td>26</td><td>25</td><td></td><td></td><td>22</td><td>21</td><td>20</td><td>19</td><td>18</td></tr> <tr><td></td><td>13</td><td>12</td><td></td><td></td><td>9</td><td>7</td><td></td><td></td><td>4</td><td>2</td></tr> </table>		55		53			49	48	47	46	44			40	39		37	36	35	34	33	31			26	25			22	21	20	19	18		13	12			9	7			4	2																
	55		53			49	48	47	46	44																																																									
		40	39		37	36	35	34	33	31																																																									
		26	25			22	21	20	19	18																																																									
	13	12			9	7			4	2																																																									
AVAILABLE	NOT APPLICABLE	34576-5803	F	0	G	BLUE	<table border="1"> <tr><td></td><td>55</td><td></td><td>53</td><td></td><td></td><td>49</td><td>48</td><td>47</td><td>46</td><td>45</td><td>44</td></tr> <tr><td></td><td></td><td>40</td><td>39</td><td></td><td>37</td><td>36</td><td>35</td><td>34</td><td>33</td><td></td><td></td></tr> <tr><td></td><td></td><td>26</td><td>25</td><td></td><td></td><td></td><td>20</td><td>19</td><td>18</td><td></td><td></td></tr> <tr><td></td><td>13</td><td>12</td><td></td><td></td><td>9</td><td>7</td><td></td><td></td><td></td><td></td><td></td></tr> </table>		55		53			49	48	47	46	45	44			40	39		37	36	35	34	33					26	25				20	19	18				13	12			9	7																	
	55		53			49	48	47	46	45	44																																																								
		40	39		37	36	35	34	33																																																										
		26	25				20	19	18																																																										
	13	12			9	7																																																													
AVAILABLE	NOT APPLICABLE	34576-5903	F	0	G	BLUE	<table border="1"> <tr><td>56</td><td></td><td></td><td>53</td><td>52</td><td></td><td></td><td></td><td>47</td><td>45</td><td>43</td></tr> <tr><td></td><td>41</td><td>40</td><td>39</td><td>38</td><td></td><td></td><td></td><td>34</td><td>33</td><td>31</td></tr> <tr><td></td><td>28</td><td>27</td><td>26</td><td>25</td><td>24</td><td></td><td></td><td>20</td><td>19</td><td>18</td></tr> <tr><td></td><td>13</td><td>12</td><td>11</td><td>10</td><td></td><td></td><td></td><td></td><td></td><td>3</td></tr> <tr><td></td><td></td><td></td><td></td><td></td><td></td><td></td><td></td><td></td><td></td><td>2</td></tr> </table>	56			53	52				47	45	43		41	40	39	38				34	33	31		28	27	26	25	24			20	19	18		13	12	11	10						3											2					
56			53	52				47	45	43																																																									
	41	40	39	38				34	33	31																																																									
	28	27	26	25	24			20	19	18																																																									
	13	12	11	10						3																																																									
										2																																																									
AVAILABLE	NOT APPLICABLE	34576-6003	F	0	G	BLUE	<table border="1"> <tr><td>56</td><td></td><td></td><td>53</td><td>52</td><td></td><td>50</td><td></td><td></td><td>47</td><td>45</td><td>43</td></tr> <tr><td></td><td></td><td>40</td><td>39</td><td>38</td><td></td><td></td><td></td><td>34</td><td>33</td><td>31</td><td>30</td></tr> <tr><td></td><td>28</td><td>27</td><td>26</td><td>25</td><td>24</td><td></td><td></td><td>20</td><td>19</td><td>18</td><td>16</td></tr> <tr><td></td><td>14</td><td>13</td><td>12</td><td>11</td><td>10</td><td></td><td></td><td></td><td>5</td><td>4</td><td>3</td></tr> <tr><td></td><td></td><td></td><td></td><td></td><td></td><td></td><td></td><td></td><td></td><td></td><td>2</td></tr> </table>	56			53	52		50			47	45	43			40	39	38				34	33	31	30		28	27	26	25	24			20	19	18	16		14	13	12	11	10				5	4	3												2
56			53	52		50			47	45	43																																																								
		40	39	38				34	33	31	30																																																								
	28	27	26	25	24			20	19	18	16																																																								
	14	13	12	11	10				5	4	3																																																								
											2																																																								
AVAILABLE	NOT APPLICABLE	34576-6103	F	0	G	BLUE	<table border="1"> <tr><td>56</td><td>55</td><td>54</td><td>53</td><td></td><td>51</td><td>49</td><td>48</td><td>47</td><td></td><td>44</td></tr> <tr><td></td><td></td><td>40</td><td>39</td><td></td><td>37</td><td>36</td><td>35</td><td>34</td><td>33</td><td>29</td></tr> <tr><td></td><td></td><td></td><td></td><td></td><td></td><td></td><td></td><td>20</td><td>19</td><td>18</td></tr> <tr><td></td><td>13</td><td>12</td><td></td><td></td><td>9</td><td>7</td><td></td><td></td><td>4</td><td>2</td></tr> </table>	56	55	54	53		51	49	48	47		44			40	39		37	36	35	34	33	29									20	19	18		13	12			9	7			4	2																
56	55	54	53		51	49	48	47		44																																																									
		40	39		37	36	35	34	33	29																																																									
								20	19	18																																																									
	13	12			9	7			4	2																																																									

<b>ENTER DESCRIPTION</b> EC NO: UAU2013-1350 DRAWN BY: 2013/02/26 CHKD: 2013/02/28 APPR: VIOSHY REV:	QUALITY SYMBOLS ∇=0 ∇=0 ∇=0	GENERAL TOLERANCES (UNLESS SPECIFIED) <table border="1"> <tr><th></th><th>mm</th><th>INCH</th></tr> <tr><td>4 PLACES</td><td>±</td><td>---</td></tr> <tr><td>3 PLACES</td><td>±</td><td>---</td></tr> <tr><td>2 PLACES</td><td>±</td><td>---</td></tr> <tr><td>1 PLACE</td><td>±</td><td>---</td></tr> <tr><td>0 PLACE</td><td>±</td><td>---</td></tr> </table>		mm	INCH	4 PLACES	±	---	3 PLACES	±	---	2 PLACES	±	---	1 PLACE	±	---	0 PLACE	±	---	DIMENSION STYLE <b>MM ONLY</b>	SCALE <b>2:1</b>	DESIGN UNITS <b>METRIC</b>	THIRD ANGLE PROJECTION 
		mm	INCH																					
	4 PLACES	±	---																					
	3 PLACES	±	---																					
2 PLACES	±	---																						
1 PLACE	±	---																						
0 PLACE	±	---																						
DRAWN BY: SKRAJENDRANA DATE: 2011/01/25 CHECKED BY: _____ DATE: _____ APPROVED BY: _____ DATE: _____	TITLE <b>MX123 18/49/56 CKT HRNS CONN ASSY</b>			MATERIAL NO. _____ DOCUMENT NO. <b>SD-34576-001</b>		SHEET NO. 9 OF 15																		
ANGULAR ± _____ DRAFT WHERE APPLICABLE MUST REMAIN WITHIN DIMENSIONS		SEE BOM TABLE		THIS DRAWING CONTAINS INFORMATION THAT IS PROPRIETARY TO MOLEX INCORPORATED AND SHOULD NOT BE USED WITHOUT WRITTEN PERMISSION																				
SIZE D																								

STATUS	GM PART #	MATERIAL #	PART/MATERIAL REVISION	WIRE DRESS OPTION	KEY OPTION	COLOR (TFA)	NUMBERS INDICATE CAVITIES OPEN FOR CIRCUITS																																																							
AVAILABLE	NOT APPLICABLE	34576-6203	G	0	G	BLUE	<table border="1"> <tr><td>55</td><td>54</td><td>53</td><td></td><td></td><td>49</td><td>48</td><td>47</td><td>46</td><td>45</td><td>44</td></tr> <tr><td></td><td>40</td><td></td><td>37</td><td>36</td><td>35</td><td>34</td><td>33</td><td></td><td></td><td></td></tr> <tr><td></td><td>26</td><td></td><td></td><td></td><td></td><td>20</td><td>19</td><td>18</td><td></td><td></td></tr> <tr><td>13</td><td>12</td><td></td><td>9</td><td>7</td><td></td><td></td><td></td><td></td><td></td><td></td></tr> </table>	55	54	53			49	48	47	46	45	44		40		37	36	35	34	33					26					20	19	18			13	12		9	7																	
55	54	53			49	48	47	46	45	44																																																				
	40		37	36	35	34	33																																																							
	26					20	19	18																																																						
13	12		9	7																																																										
AVAILABLE	NOT APPLICABLE	34576-6303	G	0	G	BLUE	<table border="1"> <tr><td>55</td><td>54</td><td>53</td><td>51</td><td>49</td><td>48</td><td>47</td><td></td><td></td><td>44</td><td></td></tr> <tr><td></td><td>40</td><td></td><td>37</td><td>36</td><td>35</td><td>34</td><td>33</td><td></td><td></td><td>29</td></tr> <tr><td></td><td>26</td><td></td><td></td><td></td><td></td><td>20</td><td>19</td><td>18</td><td>16</td><td>15</td></tr> <tr><td>13</td><td>12</td><td></td><td>9</td><td>7</td><td></td><td></td><td>4</td><td>2</td><td></td><td></td></tr> </table>	55	54	53	51	49	48	47			44			40		37	36	35	34	33			29		26					20	19	18	16	15	13	12		9	7			4	2													
55	54	53	51	49	48	47			44																																																					
	40		37	36	35	34	33			29																																																				
	26					20	19	18	16	15																																																				
13	12		9	7			4	2																																																						
AVAILABLE	NOT APPLICABLE	34576-6403	G	0	G	BLUE	<table border="1"> <tr><td>55</td><td>54</td><td></td><td></td><td>49</td><td>48</td><td>47</td><td></td><td></td><td>44</td><td></td></tr> <tr><td></td><td>41</td><td>40</td><td></td><td>37</td><td>36</td><td>35</td><td>34</td><td>33</td><td></td><td></td></tr> <tr><td></td><td></td><td></td><td></td><td></td><td></td><td></td><td>20</td><td>19</td><td>18</td><td></td></tr> <tr><td>13</td><td>12</td><td></td><td>9</td><td>8</td><td>7</td><td></td><td></td><td></td><td>3</td><td></td></tr> </table>	55	54			49	48	47			44			41	40		37	36	35	34	33										20	19	18		13	12		9	8	7				3												
55	54			49	48	47			44																																																					
	41	40		37	36	35	34	33																																																						
							20	19	18																																																					
13	12		9	8	7				3																																																					
AVAILABLE	NOT APPLICABLE	34576-6503	G	0	G	BLUE	<table border="1"> <tr><td></td><td>54</td><td></td><td></td><td></td><td></td><td>47</td><td>46</td><td>45</td><td></td><td>43</td></tr> <tr><td></td><td>41</td><td>40</td><td>39</td><td>38</td><td>37</td><td></td><td>33</td><td>32</td><td>31</td><td>30</td></tr> <tr><td>28</td><td>27</td><td>26</td><td>25</td><td>24</td><td>23</td><td></td><td>20</td><td>19</td><td>18</td><td>16</td></tr> <tr><td>13</td><td>12</td><td>11</td><td>10</td><td>9</td><td></td><td></td><td></td><td></td><td>3</td><td>2</td></tr> </table>		54					47	46	45		43		41	40	39	38	37		33	32	31	30	28	27	26	25	24	23		20	19	18	16	13	12	11	10	9					3	2											
	54					47	46	45		43																																																				
	41	40	39	38	37		33	32	31	30																																																				
28	27	26	25	24	23		20	19	18	16																																																				
13	12	11	10	9					3	2																																																				
AVAILABLE	NOT APPLICABLE	34576-6603	G	0	G	BLUE	<table border="1"> <tr><td></td><td>54</td><td></td><td></td><td></td><td></td><td>47</td><td>46</td><td>45</td><td></td><td>43</td></tr> <tr><td></td><td>41</td><td>40</td><td>39</td><td>38</td><td>37</td><td></td><td>34</td><td>33</td><td>32</td><td>31</td></tr> <tr><td>28</td><td>27</td><td>26</td><td>25</td><td>24</td><td>23</td><td></td><td>20</td><td>19</td><td>18</td><td>16</td></tr> <tr><td>13</td><td>12</td><td>11</td><td>10</td><td>9</td><td></td><td></td><td></td><td></td><td>3</td><td>2</td></tr> </table>		54					47	46	45		43		41	40	39	38	37		34	33	32	31	28	27	26	25	24	23		20	19	18	16	13	12	11	10	9					3	2											
	54					47	46	45		43																																																				
	41	40	39	38	37		34	33	32	31																																																				
28	27	26	25	24	23		20	19	18	16																																																				
13	12	11	10	9					3	2																																																				
AVAILABLE	NOT APPLICABLE	34576-6703	G	0	G	BLUE	<table border="1"> <tr><td>55</td><td></td><td></td><td>52</td><td>51</td><td></td><td>48</td><td></td><td>46</td><td>45</td><td>43</td></tr> <tr><td></td><td>41</td><td>40</td><td>39</td><td>38</td><td></td><td></td><td></td><td>33</td><td>32</td><td>31</td></tr> <tr><td>28</td><td></td><td>26</td><td>25</td><td>24</td><td></td><td></td><td></td><td>20</td><td>19</td><td>18</td></tr> <tr><td>13</td><td>12</td><td>11</td><td>10</td><td></td><td></td><td></td><td></td><td></td><td>3</td><td>2</td></tr> <tr><td></td><td></td><td></td><td></td><td></td><td></td><td></td><td></td><td></td><td></td><td>1</td></tr> </table>	55			52	51		48		46	45	43		41	40	39	38				33	32	31	28		26	25	24				20	19	18	13	12	11	10						3	2											1
55			52	51		48		46	45	43																																																				
	41	40	39	38				33	32	31																																																				
28		26	25	24				20	19	18																																																				
13	12	11	10						3	2																																																				
										1																																																				
AVAILABLE	NOT APPLICABLE	34576-6803	G	0	G	BLUE	<table border="1"> <tr><td></td><td></td><td></td><td>52</td><td></td><td></td><td>48</td><td></td><td>46</td><td>45</td><td>43</td></tr> <tr><td></td><td>41</td><td>40</td><td>39</td><td>38</td><td></td><td></td><td></td><td>33</td><td>32</td><td>31</td></tr> <tr><td>28</td><td></td><td>26</td><td>25</td><td>24</td><td></td><td></td><td></td><td>20</td><td>19</td><td>18</td></tr> <tr><td>13</td><td>12</td><td>11</td><td>10</td><td></td><td></td><td></td><td></td><td></td><td>3</td><td>2</td></tr> <tr><td></td><td></td><td></td><td></td><td></td><td></td><td></td><td></td><td></td><td></td><td>1</td></tr> </table>				52			48		46	45	43		41	40	39	38				33	32	31	28		26	25	24				20	19	18	13	12	11	10						3	2											1
			52			48		46	45	43																																																				
	41	40	39	38				33	32	31																																																				
28		26	25	24				20	19	18																																																				
13	12	11	10						3	2																																																				
										1																																																				
AVAILABLE	NOT APPLICABLE	34576-6813	G	0	G	BLUE	<table border="1"> <tr><td>56</td><td>55</td><td>54</td><td>53</td><td>51</td><td>50</td><td>49</td><td></td><td>47</td><td></td><td>44</td></tr> <tr><td></td><td></td><td></td><td>39</td><td>37</td><td>36</td><td>35</td><td>34</td><td></td><td></td><td></td></tr> <tr><td>42</td><td></td><td>27</td><td>25</td><td>23</td><td>22</td><td>21</td><td></td><td></td><td>17</td><td></td></tr> <tr><td>14</td><td></td><td></td><td>11</td><td>9</td><td>8</td><td>7</td><td>6</td><td>5</td><td>4</td><td></td></tr> </table>	56	55	54	53	51	50	49		47		44				39	37	36	35	34				42		27	25	23	22	21			17		14			11	9	8	7	6	5	4												
56	55	54	53	51	50	49		47		44																																																				
			39	37	36	35	34																																																							
42		27	25	23	22	21			17																																																					
14			11	9	8	7	6	5	4																																																					
AVAILABLE	NOT APPLICABLE	34576-6823	G	0	G	BLUE	<table border="1"> <tr><td>56</td><td>54</td><td>53</td><td></td><td>50</td><td>49</td><td>47</td><td></td><td></td><td>44</td><td></td></tr> <tr><td>42</td><td></td><td></td><td></td><td>39</td><td>37</td><td>36</td><td>35</td><td>34</td><td></td><td></td></tr> <tr><td></td><td>27</td><td>25</td><td></td><td>23</td><td>22</td><td>21</td><td></td><td></td><td>17</td><td></td></tr> <tr><td>14</td><td></td><td></td><td>11</td><td>9</td><td>8</td><td>7</td><td>6</td><td>5</td><td>4</td><td></td></tr> </table>	56	54	53		50	49	47			44		42				39	37	36	35	34				27	25		23	22	21			17		14			11	9	8	7	6	5	4												
56	54	53		50	49	47			44																																																					
42				39	37	36	35	34																																																						
	27	25		23	22	21			17																																																					
14			11	9	8	7	6	5	4																																																					

<b>ENTER DESCRIPTION</b> EC NO: UAU2013-1350 DRAWN BY: TJJ CHKD: T38 APPR: IKOSHY 2013/02/28	QUALITY SYMBOLS ∇=0 ∇=0 ∇=0	GENERAL TOLERANCES (UNLESS SPECIFIED) <table border="1"> <tr><th></th><th>mm</th><th>INCH</th></tr> <tr><td>4 PLACES</td><td>±---</td><td>±---</td></tr> <tr><td>3 PLACES</td><td>±---</td><td>±---</td></tr> <tr><td>2 PLACES</td><td>±---</td><td>±---</td></tr> <tr><td>1 PLACE</td><td>±---</td><td>±---</td></tr> <tr><td>0 PLACE</td><td>±---</td><td>±---</td></tr> </table>		mm	INCH	4 PLACES	±---	±---	3 PLACES	±---	±---	2 PLACES	±---	±---	1 PLACE	±---	±---	0 PLACE	±---	±---	DIMENSION STYLE <b>MM ONLY</b>	SCALE <b>1.5:1</b>	DESIGN UNITS <b>METRIC</b>	THIRD ANGLE PROJECTION
		mm	INCH																					
	4 PLACES	±---	±---																					
	3 PLACES	±---	±---																					
2 PLACES	±---	±---																						
1 PLACE	±---	±---																						
0 PLACE	±---	±---																						
DRAFT WHERE APPLICABLE MUST REMAIN WITHIN DIMENSIONS	MATERIAL NO.	DOCUMENT NO.	DRAWN BY: SKRAJENDRANA DATE: 2011/01/25	CHECKED BY:	DATE:	APPROVED BY:	DATE:																	
ANGULAR ±---°	SEE BOM TABLE	SD-34576-001	TITLE <b>MX123</b> <b>18/49/56 CKT</b> <b>HRNS CONN ASSY</b> <b>molex</b>	SHEET NO. 10 OF 45	SIZE <b>D</b>	THIS DRAWING CONTAINS INFORMATION THAT IS PROPRIETARY TO MOLEX INCORPORATED AND SHOULD NOT BE USED WITHOUT WRITTEN PERMISSION																		

20 19 18 17 16 15 14 13 12 11 10 9 8 7 6 5 4 3 2 1

STATUS	GM PART #	MATERIAL #	PART/MATERIAL REVISION	WIRE DRESS OPTION	KEY OPTION	COLOR (TPA)	NUMBERS INDICATE CAVITIES OPEN FOR CIRCUITS																																																										
AVAILABLE	NOT APPLICABLE	34576-6833	G	0	G	BLUE	<table border="1"> <tr><td>56</td><td>54</td><td>53</td><td></td><td></td><td></td><td>50</td><td>49</td><td></td><td>47</td><td></td><td></td><td></td><td></td></tr> <tr><td></td><td></td><td></td><td></td><td></td><td></td><td></td><td>21</td><td></td><td></td><td></td><td>17</td><td></td><td></td></tr> <tr><td>14</td><td></td><td>11</td><td>9</td><td>8</td><td>7</td><td>6</td><td>5</td><td>4</td><td></td><td></td><td></td><td></td><td></td></tr> </table>	56	54	53				50	49		47												21				17			14		11	9	8	7	6	5	4																					
56	54	53				50	49		47																																																								
							21				17																																																						
14		11	9	8	7	6	5	4																																																									
AVAILABLE	NOT APPLICABLE	34576-6843	G	0	G	BLUE	<table border="1"> <tr><td>56</td><td>54</td><td>53</td><td>52</td><td></td><td></td><td></td><td></td><td></td><td>47</td><td>46</td><td>45</td><td>43</td><td></td></tr> <tr><td>41</td><td>40</td><td>39</td><td>38</td><td>37</td><td></td><td></td><td></td><td></td><td>33</td><td>32</td><td>31</td><td>30</td><td>29</td></tr> <tr><td>28</td><td>27</td><td>26</td><td>25</td><td>24</td><td>23</td><td></td><td></td><td>20</td><td>19</td><td>18</td><td></td><td>16</td><td></td></tr> <tr><td>13</td><td>12</td><td>11</td><td>10</td><td>9</td><td></td><td></td><td></td><td></td><td></td><td></td><td>3</td><td>2</td><td></td></tr> </table>	56	54	53	52						47	46	45	43		41	40	39	38	37					33	32	31	30	29	28	27	26	25	24	23			20	19	18		16		13	12	11	10	9							3	2			
56	54	53	52						47	46	45	43																																																					
41	40	39	38	37					33	32	31	30	29																																																				
28	27	26	25	24	23			20	19	18		16																																																					
13	12	11	10	9							3	2																																																					
AVAILABLE	NOT APPLICABLE	34576-6853	G	0	G	BLUE	<table border="1"> <tr><td>56</td><td>54</td><td>53</td><td>52</td><td></td><td></td><td></td><td></td><td></td><td>47</td><td>46</td><td>45</td><td>43</td><td></td></tr> <tr><td>41</td><td>40</td><td>39</td><td>38</td><td>37</td><td></td><td></td><td></td><td>34</td><td>33</td><td>32</td><td>31</td><td>30</td><td>29</td></tr> <tr><td>28</td><td>27</td><td>26</td><td>25</td><td>24</td><td>23</td><td></td><td></td><td>20</td><td>19</td><td>18</td><td></td><td>16</td><td></td></tr> <tr><td>13</td><td>12</td><td>11</td><td>10</td><td>9</td><td></td><td></td><td></td><td></td><td></td><td></td><td>3</td><td>2</td><td></td></tr> </table>	56	54	53	52						47	46	45	43		41	40	39	38	37				34	33	32	31	30	29	28	27	26	25	24	23			20	19	18		16		13	12	11	10	9							3	2			
56	54	53	52						47	46	45	43																																																					
41	40	39	38	37				34	33	32	31	30	29																																																				
28	27	26	25	24	23			20	19	18		16																																																					
13	12	11	10	9							3	2																																																					
AVAILABLE	NOT APPLICABLE	34576-6863	G	0	G	BLUE	<table border="1"> <tr><td></td><td>55</td><td></td><td>52</td><td>51</td><td></td><td></td><td></td><td>48</td><td>46</td><td>45</td><td>43</td><td></td><td></td></tr> <tr><td>41</td><td>40</td><td></td><td>38</td><td></td><td></td><td></td><td></td><td>33</td><td>32</td><td>31</td><td>30</td><td>29</td><td></td></tr> <tr><td>28</td><td></td><td>26</td><td>24</td><td></td><td></td><td></td><td></td><td>20</td><td>19</td><td>18</td><td></td><td>16</td><td>15</td></tr> <tr><td>13</td><td>12</td><td></td><td>10</td><td></td><td></td><td></td><td></td><td></td><td></td><td></td><td>3</td><td>2</td><td>1</td></tr> </table>		55		52	51				48	46	45	43			41	40		38					33	32	31	30	29		28		26	24					20	19	18		16	15	13	12		10								3	2	1		
	55		52	51				48	46	45	43																																																						
41	40		38					33	32	31	30	29																																																					
28		26	24					20	19	18		16	15																																																				
13	12		10								3	2	1																																																				
AVAILABLE	NOT APPLICABLE	34576-6873	G	0	G	BLUE	<table border="1"> <tr><td></td><td></td><td></td><td>52</td><td></td><td></td><td></td><td></td><td>48</td><td>46</td><td>45</td><td>43</td><td></td><td></td></tr> <tr><td>41</td><td>40</td><td></td><td>38</td><td></td><td></td><td></td><td></td><td>33</td><td>32</td><td>31</td><td>30</td><td>29</td><td></td></tr> <tr><td>28</td><td></td><td>26</td><td>24</td><td></td><td></td><td></td><td></td><td>20</td><td>19</td><td>18</td><td></td><td>16</td><td>15</td></tr> <tr><td>13</td><td>12</td><td></td><td>10</td><td></td><td></td><td></td><td></td><td></td><td></td><td></td><td>3</td><td>2</td><td>1</td></tr> </table>				52					48	46	45	43			41	40		38					33	32	31	30	29		28		26	24					20	19	18		16	15	13	12		10								3	2	1		
			52					48	46	45	43																																																						
41	40		38					33	32	31	30	29																																																					
28		26	24					20	19	18		16	15																																																				
13	12		10								3	2	1																																																				
AVAILABLE	NOT APPLICABLE	34576-6883	G	0	G	BLUE	<table border="1"> <tr><td>56</td><td>54</td><td></td><td>52</td><td></td><td></td><td></td><td></td><td></td><td>47</td><td>46</td><td>45</td><td>43</td><td></td></tr> <tr><td>41</td><td>40</td><td>39</td><td>38</td><td>37</td><td></td><td></td><td></td><td></td><td>34</td><td>33</td><td>32</td><td>31</td><td>30</td><td>29</td></tr> <tr><td>28</td><td>27</td><td>26</td><td>25</td><td>24</td><td>23</td><td></td><td></td><td></td><td>20</td><td>19</td><td>18</td><td></td><td>16</td><td></td></tr> <tr><td>13</td><td>12</td><td>11</td><td>10</td><td>9</td><td></td><td></td><td></td><td></td><td></td><td></td><td>3</td><td>2</td><td></td></tr> </table>	56	54		52						47	46	45	43		41	40	39	38	37					34	33	32	31	30	29	28	27	26	25	24	23				20	19	18		16		13	12	11	10	9							3	2	
56	54		52						47	46	45	43																																																					
41	40	39	38	37					34	33	32	31	30	29																																																			
28	27	26	25	24	23				20	19	18		16																																																				
13	12	11	10	9							3	2																																																					
AVAILABLE	NOT APPLICABLE	34576-6893	G	0	G	BLUE	<table border="1"> <tr><td></td><td>54</td><td>53</td><td></td><td></td><td></td><td></td><td></td><td></td><td>47</td><td>46</td><td>45</td><td></td><td></td></tr> <tr><td>41</td><td>40</td><td></td><td>38</td><td></td><td></td><td></td><td></td><td></td><td>33</td><td>32</td><td>31</td><td>30</td><td>29</td></tr> <tr><td>28</td><td>27</td><td>26</td><td>25</td><td>24</td><td></td><td></td><td></td><td></td><td>20</td><td>19</td><td>18</td><td></td><td>16</td></tr> <tr><td>13</td><td>12</td><td>11</td><td>10</td><td></td><td></td><td></td><td>8</td><td></td><td></td><td></td><td>3</td><td>2</td><td></td></tr> </table>		54	53							47	46	45			41	40		38						33	32	31	30	29	28	27	26	25	24					20	19	18		16	13	12	11	10				8				3	2			
	54	53							47	46	45																																																						
41	40		38						33	32	31	30	29																																																				
28	27	26	25	24					20	19	18		16																																																				
13	12	11	10				8				3	2																																																					
ACTIVE	NOT APPLICABLE	34576-6913	F	9	G	BLUE	<table border="1"> <tr><td></td><td>54</td><td>53</td><td></td><td></td><td></td><td></td><td></td><td></td><td>47</td><td>46</td><td>45</td><td>43</td><td></td></tr> <tr><td>41</td><td>40</td><td></td><td>38</td><td></td><td></td><td></td><td></td><td></td><td>33</td><td>32</td><td>31</td><td>30</td><td>29</td></tr> <tr><td>28</td><td>27</td><td>26</td><td>25</td><td>24</td><td></td><td></td><td></td><td></td><td>20</td><td>19</td><td>18</td><td></td><td>16</td></tr> <tr><td>13</td><td>12</td><td>11</td><td>10</td><td></td><td></td><td></td><td>8</td><td></td><td></td><td></td><td>3</td><td>2</td><td></td></tr> </table>		54	53							47	46	45	43		41	40		38						33	32	31	30	29	28	27	26	25	24					20	19	18		16	13	12	11	10				8				3	2			
	54	53							47	46	45	43																																																					
41	40		38						33	32	31	30	29																																																				
28	27	26	25	24					20	19	18		16																																																				
13	12	11	10				8				3	2																																																					
ACTIVE	NOT APPLICABLE	34576-6923	F	9	G	BLUE	<table border="1"> <tr><td></td><td>54</td><td>53</td><td></td><td></td><td></td><td></td><td></td><td></td><td>47</td><td>46</td><td>45</td><td>43</td><td></td></tr> <tr><td>41</td><td>40</td><td>39</td><td>38</td><td></td><td></td><td></td><td></td><td></td><td>33</td><td>32</td><td>31</td><td>30</td><td>29</td></tr> <tr><td>28</td><td>27</td><td>26</td><td>25</td><td>24</td><td>23</td><td></td><td></td><td></td><td>20</td><td>19</td><td>18</td><td></td><td>16</td></tr> <tr><td>13</td><td>12</td><td>11</td><td>10</td><td>9</td><td>8</td><td></td><td></td><td></td><td></td><td></td><td>3</td><td>2</td><td></td></tr> </table>		54	53							47	46	45	43		41	40	39	38						33	32	31	30	29	28	27	26	25	24	23				20	19	18		16	13	12	11	10	9	8						3	2			
	54	53							47	46	45	43																																																					
41	40	39	38						33	32	31	30	29																																																				
28	27	26	25	24	23				20	19	18		16																																																				
13	12	11	10	9	8						3	2																																																					

<b>ENTER DESCRIPTION</b> EC NO: UAU2013-1350 DRAWN BY: SKRAJENDRANA CHKD: SKRAJENDRANA APPR: IKOSHY REV: 1 DESCRIPTION: 2013/02/26 DATE: 2013/02/26	<b>QUALITY SYMBOLS</b> ∇=0 ∇=0 ∇=0	<b>GENERAL TOLERANCES (UNLESS SPECIFIED)</b> <table border="1"> <tr><td></td><td>mm</td><td>INCH</td></tr> <tr><td>4 PLACES</td><td>±----</td><td>±----</td></tr> <tr><td>3 PLACES</td><td>±----</td><td>±----</td></tr> <tr><td>2 PLACES</td><td>±----</td><td>±----</td></tr> <tr><td>1 PLACE</td><td>±----</td><td>±----</td></tr> <tr><td>0 PLACE</td><td>±----</td><td>±----</td></tr> </table>		mm	INCH	4 PLACES	±----	±----	3 PLACES	±----	±----	2 PLACES	±----	±----	1 PLACE	±----	±----	0 PLACE	±----	±----	<b>DIMENSION STYLE</b> <b>MM ONLY</b>	<b>SCALE</b> <b>1:1</b>	<b>DESIGN UNITS</b> <b>METRIC</b>	<b>THIRD ANGLE PROJECTION</b>
		mm	INCH																					
	4 PLACES	±----	±----																					
	3 PLACES	±----	±----																					
2 PLACES	±----	±----																						
1 PLACE	±----	±----																						
0 PLACE	±----	±----																						
<b>DATE</b> 2011/01/25	<b>DATE</b> 2011/01/25	<b>DATE</b> 2011/01/25	<b>MATERIAL NO.</b> <b>SEE BOM TABLE</b>	<b>DOCUMENT NO.</b> <b>SD-34576-001</b>	<b>TITLE</b> <b>MX123</b> <b>18/49/56 CKT</b> <b>HRNS CONN ASSY</b> <b>molex</b>	<b>SHEET NO.</b> <b>11 OF 45</b>																		
<b>ANGULAR ±----</b> <b>DRAFT WHERE APPLICABLE</b> <b>MUST REMAIN WITHIN DIMENSIONS</b>			<b>THIS DRAWING CONTAINS INFORMATION THAT IS PROPRIETARY TO MOLEX INCORPORATED AND SHOULD NOT BE USED WITHOUT WRITTEN PERMISSION</b>																					
<b>SIZE D</b>																								

19 18 17 16 15 14 13 12 11 10 9 8 7 6 5 4 3 2 1

STATUS	GM PART #	MATERIAL #	PART/MATERIAL REVISION	WIRE DRESS OPTION	KEY OPTION	COLOR (TPA)	NUMBERS INDICATE CAVITIES OPEN FOR CIRCUITS																																																																	
TOOL DES. REL.	NOT APPLICABLE	34851-0025	A	0	G	BLUE																																																																		
TOOL DES. REL.	NOT APPLICABLE	34851-0026	A	0	H	ST GRY																																																																		
AVAILABLE	NOT APPLICABLE	34576-6933	G	0	G	BLUE	<table border="1"> <tr><td>55</td><td>54</td><td>53</td><td></td><td></td><td></td><td>49</td><td>48</td><td>47</td><td>46</td><td>45</td><td>44</td></tr> <tr><td></td><td>40</td><td></td><td></td><td></td><td></td><td>37</td><td>36</td><td>35</td><td>34</td><td>33</td><td></td></tr> <tr><td></td><td></td><td>26</td><td></td><td></td><td></td><td></td><td></td><td>20</td><td>19</td><td>18</td><td></td></tr> <tr><td></td><td></td><td></td><td></td><td></td><td></td><td>9</td><td>7</td><td></td><td></td><td></td><td></td></tr> </table>	55	54	53				49	48	47	46	45	44		40					37	36	35	34	33				26						20	19	18								9	7																					
55	54	53				49	48	47	46	45	44																																																													
	40					37	36	35	34	33																																																														
		26						20	19	18																																																														
						9	7																																																																	
AVAILABLE	NOT APPLICABLE	34576-6943	G	9	G	BLUE	<table border="1"> <tr><td></td><td>54</td><td>53</td><td></td><td></td><td></td><td></td><td></td><td>47</td><td>46</td><td>45</td><td>43</td></tr> <tr><td></td><td>41</td><td>40</td><td>38</td><td></td><td></td><td></td><td></td><td>33</td><td>32</td><td>31</td><td>30</td></tr> <tr><td>28</td><td>27</td><td>26</td><td>25</td><td>24</td><td></td><td></td><td></td><td>20</td><td>19</td><td>18</td><td>16</td></tr> <tr><td></td><td></td><td></td><td></td><td></td><td></td><td>8</td><td></td><td></td><td></td><td></td><td>3</td></tr> <tr><td>13</td><td>12</td><td>11</td><td>10</td><td></td><td></td><td></td><td></td><td></td><td></td><td></td><td>2</td></tr> </table>		54	53						47	46	45	43		41	40	38					33	32	31	30	28	27	26	25	24				20	19	18	16							8					3	13	12	11	10								2					
	54	53						47	46	45	43																																																													
	41	40	38					33	32	31	30																																																													
28	27	26	25	24				20	19	18	16																																																													
						8					3																																																													
13	12	11	10								2																																																													
AVAILABLE	NOT APPLICABLE	34576-6953	G	0	G	BLUE	<table border="1"> <tr><td></td><td>54</td><td>53</td><td></td><td></td><td></td><td></td><td></td><td>47</td><td>46</td><td>45</td><td>43</td></tr> <tr><td></td><td>41</td><td>40</td><td>39</td><td>38</td><td></td><td></td><td></td><td>33</td><td>32</td><td>31</td><td>30</td></tr> <tr><td>28</td><td>27</td><td>26</td><td>25</td><td>24</td><td>23</td><td></td><td></td><td>20</td><td>19</td><td>18</td><td>16</td></tr> <tr><td></td><td></td><td></td><td></td><td></td><td></td><td>9</td><td>8</td><td></td><td></td><td></td><td>3</td></tr> <tr><td>13</td><td>12</td><td>11</td><td>10</td><td></td><td></td><td></td><td></td><td></td><td></td><td></td><td>2</td></tr> </table>		54	53						47	46	45	43		41	40	39	38				33	32	31	30	28	27	26	25	24	23			20	19	18	16							9	8				3	13	12	11	10								2					
	54	53						47	46	45	43																																																													
	41	40	39	38				33	32	31	30																																																													
28	27	26	25	24	23			20	19	18	16																																																													
						9	8				3																																																													
13	12	11	10								2																																																													
AVAILABLE	NOT APPLICABLE	34576-6963	G	0	G	BLUE	<table border="1"> <tr><td>56</td><td>54</td><td>53</td><td>52</td><td></td><td></td><td></td><td></td><td>47</td><td>46</td><td>45</td><td>43</td></tr> <tr><td></td><td>41</td><td>40</td><td>39</td><td>38</td><td></td><td></td><td></td><td>34</td><td>33</td><td>32</td><td>31</td></tr> <tr><td>28</td><td>27</td><td>26</td><td>25</td><td>24</td><td>23</td><td></td><td></td><td>20</td><td>19</td><td>18</td><td>16</td></tr> <tr><td></td><td></td><td></td><td></td><td></td><td></td><td>9</td><td>8</td><td></td><td></td><td></td><td>3</td></tr> <tr><td>13</td><td>12</td><td>11</td><td>10</td><td></td><td></td><td></td><td></td><td></td><td></td><td></td><td>2</td></tr> </table>	56	54	53	52					47	46	45	43		41	40	39	38				34	33	32	31	28	27	26	25	24	23			20	19	18	16							9	8				3	13	12	11	10								2					
56	54	53	52					47	46	45	43																																																													
	41	40	39	38				34	33	32	31																																																													
28	27	26	25	24	23			20	19	18	16																																																													
						9	8				3																																																													
13	12	11	10								2																																																													
AVAILABLE	NOT APPLICABLE	34576-6973	G	0	G	BLUE	<table border="1"> <tr><td>56</td><td></td><td></td><td>52</td><td>51</td><td>50</td><td></td><td></td><td></td><td></td><td></td><td>43</td></tr> <tr><td>42</td><td>41</td><td>39</td><td>38</td><td></td><td></td><td></td><td></td><td></td><td></td><td>32</td><td>31</td></tr> <tr><td>28</td><td>27</td><td>25</td><td>24</td><td>23</td><td>22</td><td>21</td><td></td><td></td><td></td><td>17</td><td>16</td></tr> <tr><td></td><td></td><td></td><td></td><td></td><td></td><td></td><td>8</td><td>6</td><td>5</td><td>4</td><td>3</td></tr> <tr><td>14</td><td></td><td></td><td>11</td><td>10</td><td></td><td></td><td></td><td></td><td></td><td></td><td>2</td></tr> </table>	56			52	51	50						43	42	41	39	38							32	31	28	27	25	24	23	22	21				17	16								8	6	5	4	3	14			11	10							2					
56			52	51	50						43																																																													
42	41	39	38							32	31																																																													
28	27	25	24	23	22	21				17	16																																																													
							8	6	5	4	3																																																													
14			11	10							2																																																													
AVAILABLE	NOT APPLICABLE	34576-6983	G	0	G	BLUE	<table border="1"> <tr><td></td><td>54</td><td>53</td><td></td><td></td><td></td><td></td><td></td><td></td><td>46</td><td>44</td><td></td></tr> <tr><td></td><td>40</td><td>39</td><td>38</td><td>37</td><td>36</td><td></td><td></td><td></td><td>32</td><td>31</td><td>30</td></tr> <tr><td></td><td></td><td>25</td><td>24</td><td>23</td><td>22</td><td>21</td><td>20</td><td>19</td><td></td><td></td><td></td></tr> <tr><td></td><td></td><td></td><td>11</td><td>10</td><td>9</td><td>8</td><td>7</td><td>6</td><td>5</td><td>4</td><td>2</td></tr> </table>		54	53							46	44			40	39	38	37	36				32	31	30			25	24	23	22	21	20	19							11	10	9	8	7	6	5	4	2																	
	54	53							46	44																																																														
	40	39	38	37	36				32	31	30																																																													
		25	24	23	22	21	20	19																																																																
			11	10	9	8	7	6	5	4	2																																																													
AVAILABLE	NOT APPLICABLE	34576-6993	G	0	G	BLUE	<table border="1"> <tr><td>56</td><td>55</td><td>54</td><td>53</td><td>52</td><td>51</td><td></td><td></td><td></td><td>47</td><td>46</td><td>45</td><td>43</td></tr> <tr><td></td><td>41</td><td>40</td><td>38</td><td></td><td></td><td></td><td></td><td></td><td>33</td><td>32</td><td>31</td><td>30</td></tr> <tr><td>28</td><td>27</td><td>26</td><td>25</td><td>24</td><td></td><td></td><td></td><td></td><td>20</td><td>19</td><td>18</td><td>16</td></tr> <tr><td></td><td></td><td></td><td></td><td></td><td></td><td></td><td></td><td></td><td></td><td></td><td></td><td>3</td></tr> <tr><td>13</td><td>12</td><td>11</td><td>10</td><td></td><td></td><td></td><td></td><td></td><td></td><td></td><td></td><td>2</td></tr> </table>	56	55	54	53	52	51				47	46	45	43		41	40	38						33	32	31	30	28	27	26	25	24					20	19	18	16													3	13	12	11	10									2
56	55	54	53	52	51				47	46	45	43																																																												
	41	40	38						33	32	31	30																																																												
28	27	26	25	24					20	19	18	16																																																												
												3																																																												
13	12	11	10									2																																																												

<b>ENTER DESCRIPTION</b> EC NO. UAU2013-1350 DRAWN BY TJB CHKD: APPR: WKSHY 2013/02/26 2013/02/28	QUALITY SYMBOLS	GENERAL TOLERANCES (UNLESS SPECIFIED)	DIMENSION STYLE	SCALE	DESIGN UNITS	THIRD ANGLE PROJECTION
	▽=0	4 PLACES ±--- ±---	MM ONLY	1:1	METRIC	
	▽=0	3 PLACES ±--- ±---	mm INCH			
	▽=0	2 PLACES ±--- ±---				
	1 PLACE ±--- ±---	ANGULAR ±---				
	0 PLACE ±--- ±---	DRAFT WHERE APPLICABLE MUST REMAIN WITHIN DIMENSIONS				
			DRAWN BY SKRAJENDRANA	DATE 2011/01/25	TITLE	
			CHECKED BY	DATE	MX123 18/49/56 CKT HRNS CONN ASSY	
			APPROVED BY	DATE	molex	
			MATERIAL NO.	DOCUMENT NO.	SD-34576-001	
			SIZE D	THIS DRAWING CONTAINS INFORMATION THAT IS PROPRIETARY TO MOLEX INCORPORATED AND SHOULD NOT BE USED WITHOUT WRITTEN PERMISSION		
					SHEET NO. 12 OF 15	

STATUS	GM PART #	MATERIAL #	PART/MATERIAL REVISION	WIRE DRESS OPTION	KEY OPTION	COLOR (TPA)	NUMBERS INDICATE CAVITIES OPEN FOR CIRCUITS																																																						
AVAILABLE	NOT APPLICABLE	34576-7003	G	0	G	BLUE	<table border="1"> <tr><td>56</td><td>55</td><td>54</td><td>52</td><td>51</td><td></td><td></td><td>47</td><td>46</td><td>45</td><td>43</td></tr> <tr><td>41</td><td>40</td><td>38</td><td></td><td></td><td></td><td></td><td>33</td><td>32</td><td>31</td><td>30</td><td>29</td></tr> <tr><td>28</td><td>27</td><td>26</td><td>25</td><td>24</td><td></td><td></td><td>20</td><td>19</td><td>18</td><td>16</td><td></td></tr> <tr><td>13</td><td>12</td><td>11</td><td>10</td><td>8</td><td></td><td></td><td></td><td></td><td>3</td><td>2</td><td></td></tr> </table>	56	55	54	52	51			47	46	45	43	41	40	38					33	32	31	30	29	28	27	26	25	24			20	19	18	16		13	12	11	10	8					3	2								
56	55	54	52	51			47	46	45	43																																																			
41	40	38					33	32	31	30	29																																																		
28	27	26	25	24			20	19	18	16																																																			
13	12	11	10	8					3	2																																																			
AVAILABLE	NOT APPLICABLE	34576-7013	G	0	G	BLUE	<table border="1"> <tr><td>56</td><td>55</td><td>54</td><td>53</td><td>52</td><td>51</td><td></td><td></td><td>47</td><td>46</td><td>45</td><td>43</td></tr> <tr><td>41</td><td>40</td><td>38</td><td></td><td></td><td></td><td></td><td>34</td><td>33</td><td>32</td><td>31</td><td>30</td><td>29</td></tr> <tr><td>28</td><td>27</td><td>26</td><td>25</td><td>24</td><td></td><td></td><td>20</td><td>19</td><td>18</td><td>16</td><td></td><td></td></tr> <tr><td>13</td><td>11</td><td>10</td><td></td><td></td><td>8</td><td></td><td></td><td></td><td></td><td>3</td><td>2</td><td></td></tr> </table>	56	55	54	53	52	51			47	46	45	43	41	40	38					34	33	32	31	30	29	28	27	26	25	24			20	19	18	16			13	11	10			8					3	2				
56	55	54	53	52	51			47	46	45	43																																																		
41	40	38					34	33	32	31	30	29																																																	
28	27	26	25	24			20	19	18	16																																																			
13	11	10			8					3	2																																																		
AVAILABLE	NOT APPLICABLE	34576-7023	G	0	G	BLUE	<table border="1"> <tr><td>56</td><td>55</td><td>54</td><td>52</td><td>51</td><td></td><td></td><td></td><td>47</td><td>46</td><td>45</td><td>43</td></tr> <tr><td>41</td><td>40</td><td>38</td><td></td><td></td><td></td><td></td><td>34</td><td>33</td><td>32</td><td>31</td><td>30</td><td>29</td></tr> <tr><td>28</td><td>27</td><td>26</td><td>25</td><td>24</td><td></td><td></td><td>20</td><td>19</td><td>18</td><td>16</td><td></td><td></td></tr> <tr><td>13</td><td>12</td><td>11</td><td>10</td><td>8</td><td></td><td></td><td></td><td></td><td></td><td>3</td><td>2</td><td></td></tr> </table>	56	55	54	52	51				47	46	45	43	41	40	38					34	33	32	31	30	29	28	27	26	25	24			20	19	18	16			13	12	11	10	8						3	2				
56	55	54	52	51				47	46	45	43																																																		
41	40	38					34	33	32	31	30	29																																																	
28	27	26	25	24			20	19	18	16																																																			
13	12	11	10	8						3	2																																																		
AVAILABLE	NOT APPLICABLE	34576-7033	G	0	G	BLUE	<table border="1"> <tr><td>56</td><td>54</td><td>53</td><td>52</td><td></td><td></td><td></td><td></td><td>47</td><td>46</td><td>45</td><td>43</td></tr> <tr><td>41</td><td>40</td><td>38</td><td></td><td></td><td></td><td></td><td></td><td>33</td><td>32</td><td>31</td><td>30</td><td>29</td></tr> <tr><td>28</td><td>27</td><td>26</td><td>25</td><td>24</td><td></td><td></td><td></td><td>20</td><td>19</td><td>18</td><td>16</td><td></td></tr> <tr><td>13</td><td>12</td><td>11</td><td>10</td><td>8</td><td></td><td></td><td></td><td></td><td></td><td>3</td><td>2</td><td></td></tr> </table>	56	54	53	52					47	46	45	43	41	40	38						33	32	31	30	29	28	27	26	25	24				20	19	18	16		13	12	11	10	8						3	2				
56	54	53	52					47	46	45	43																																																		
41	40	38						33	32	31	30	29																																																	
28	27	26	25	24				20	19	18	16																																																		
13	12	11	10	8						3	2																																																		
AVAILABLE	NOT APPLICABLE	34576-7043	G	0	G	BLUE	<table border="1"> <tr><td>56</td><td>54</td><td>52</td><td></td><td></td><td></td><td></td><td></td><td>47</td><td>46</td><td>45</td><td>43</td></tr> <tr><td>41</td><td>40</td><td>38</td><td></td><td></td><td></td><td></td><td></td><td>33</td><td>32</td><td>31</td><td>30</td><td>29</td></tr> <tr><td>28</td><td>27</td><td>26</td><td>25</td><td>24</td><td></td><td></td><td></td><td>20</td><td>19</td><td>18</td><td>16</td><td></td></tr> <tr><td>13</td><td>12</td><td>11</td><td>10</td><td>8</td><td></td><td></td><td></td><td></td><td></td><td>3</td><td>2</td><td></td></tr> </table>	56	54	52						47	46	45	43	41	40	38						33	32	31	30	29	28	27	26	25	24				20	19	18	16		13	12	11	10	8						3	2				
56	54	52						47	46	45	43																																																		
41	40	38						33	32	31	30	29																																																	
28	27	26	25	24				20	19	18	16																																																		
13	12	11	10	8						3	2																																																		
AVAILABLE	NOT APPLICABLE	34576-7053	G	0	G	BLUE	<table border="1"> <tr><td>56</td><td>54</td><td>53</td><td>52</td><td></td><td></td><td></td><td></td><td>47</td><td>46</td><td>45</td><td>43</td></tr> <tr><td>41</td><td>40</td><td>38</td><td></td><td></td><td></td><td></td><td></td><td>34</td><td>33</td><td>32</td><td>31</td><td>30</td><td>29</td></tr> <tr><td>28</td><td>27</td><td>26</td><td>25</td><td>24</td><td></td><td></td><td></td><td>20</td><td>19</td><td>18</td><td>16</td><td></td><td></td></tr> <tr><td>13</td><td>12</td><td>11</td><td>10</td><td>8</td><td></td><td></td><td></td><td></td><td></td><td>3</td><td>2</td><td></td><td></td></tr> </table>	56	54	53	52					47	46	45	43	41	40	38						34	33	32	31	30	29	28	27	26	25	24				20	19	18	16			13	12	11	10	8						3	2		
56	54	53	52					47	46	45	43																																																		
41	40	38						34	33	32	31	30	29																																																
28	27	26	25	24				20	19	18	16																																																		
13	12	11	10	8						3	2																																																		
AVAILABLE	NOT APPLICABLE	34576-7063	G	0	G	BLUE	<table border="1"> <tr><td>56</td><td>54</td><td>52</td><td></td><td></td><td></td><td></td><td></td><td>47</td><td>46</td><td>45</td><td>43</td></tr> <tr><td>41</td><td>40</td><td>38</td><td></td><td></td><td></td><td></td><td></td><td>34</td><td>33</td><td>32</td><td>31</td><td>30</td><td>29</td></tr> <tr><td>28</td><td>27</td><td>26</td><td>25</td><td>24</td><td></td><td></td><td></td><td>20</td><td>19</td><td>18</td><td>16</td><td></td><td></td></tr> <tr><td>13</td><td>12</td><td>11</td><td>10</td><td>8</td><td></td><td></td><td></td><td></td><td></td><td>3</td><td>2</td><td></td><td></td></tr> </table>	56	54	52						47	46	45	43	41	40	38						34	33	32	31	30	29	28	27	26	25	24				20	19	18	16			13	12	11	10	8						3	2		
56	54	52						47	46	45	43																																																		
41	40	38						34	33	32	31	30	29																																																
28	27	26	25	24				20	19	18	16																																																		
13	12	11	10	8						3	2																																																		
AVAILABLE	NOT APPLICABLE	34576-7073	G	0	G	BLUE	<table border="1"> <tr><td></td><td>54</td><td>53</td><td>52</td><td></td><td></td><td></td><td></td><td>47</td><td>46</td><td>45</td><td>43</td></tr> <tr><td>41</td><td>40</td><td>38</td><td></td><td></td><td></td><td></td><td></td><td>33</td><td>32</td><td>31</td><td>30</td><td>29</td></tr> <tr><td>28</td><td>27</td><td>26</td><td>25</td><td>24</td><td></td><td></td><td></td><td>20</td><td>19</td><td>18</td><td>16</td><td></td><td></td></tr> <tr><td>13</td><td>12</td><td>11</td><td>10</td><td>8</td><td></td><td></td><td></td><td></td><td></td><td>3</td><td>2</td><td></td><td></td></tr> </table>		54	53	52					47	46	45	43	41	40	38						33	32	31	30	29	28	27	26	25	24				20	19	18	16			13	12	11	10	8						3	2			
	54	53	52					47	46	45	43																																																		
41	40	38						33	32	31	30	29																																																	
28	27	26	25	24				20	19	18	16																																																		
13	12	11	10	8						3	2																																																		
AVAILABLE	NOT APPLICABLE	34576-7083	G	0	G	BLUE	<table border="1"> <tr><td></td><td>54</td><td>53</td><td>52</td><td></td><td></td><td></td><td></td><td>47</td><td>46</td><td>45</td><td>43</td></tr> <tr><td>41</td><td>40</td><td>38</td><td></td><td></td><td></td><td></td><td></td><td>34</td><td>33</td><td>32</td><td>31</td><td>30</td><td>29</td></tr> <tr><td>28</td><td>27</td><td>26</td><td>25</td><td>24</td><td></td><td></td><td></td><td>20</td><td>19</td><td>18</td><td>16</td><td></td><td></td></tr> <tr><td>13</td><td>12</td><td>11</td><td>10</td><td>8</td><td></td><td></td><td></td><td></td><td></td><td>3</td><td>2</td><td></td><td></td></tr> </table>		54	53	52					47	46	45	43	41	40	38						34	33	32	31	30	29	28	27	26	25	24				20	19	18	16			13	12	11	10	8						3	2		
	54	53	52					47	46	45	43																																																		
41	40	38						34	33	32	31	30	29																																																
28	27	26	25	24				20	19	18	16																																																		
13	12	11	10	8						3	2																																																		

<b>ENTER DESCRIPTION</b> ELEC NO: UAU2013-1350 DRAWN BY: 2013/02/26 CHKD: APPR: IKOSHY REV: 2013/02/28	QUALITY SYMBOLS ∇=0 ∇=0 ∇=0	GENERAL TOLERANCES (UNLESS SPECIFIED) mm INCH 4 PLACES ± --- ± --- 3 PLACES ± --- ± --- 2 PLACES ± --- ± --- 1 PLACE ± --- ± --- 0 PLACE ± --- ± --- ANGULAR ± ---° DRAFT WHERE APPLICABLE MUST REMAIN WITHIN DIMENSIONS	DIMENSION STYLE <b>MM ONLY</b> DRAWN BY: SKRAJENDRANA 2011/01/25 CHECKED BY: DATE APPROVED BY: DATE	SCALE <b>1:1</b> DESIGN UNITS <b>METRIC</b> THIRD ANGLE PROJECTION	TITLE <b>MX123                  18/49/56 CKT                  HRNS CONN ASSY</b> <b>molex</b>	MATERIAL NO. <b>SEE BOM TABLE</b>	DOCUMENT NO. <b>SD-34576-001</b>	SHEET NO. <b>13 OF 15</b>
	THIS DRAWING CONTAINS INFORMATION THAT IS PROPRIETARY TO MOLEX INCORPORATED AND SHOULD NOT BE USED WITHOUT WRITTEN PERMISSION							

STATUS	GM PART #	MATERIAL #	PART/MATERIAL REVISION	WIRE DRESS OPTION	KEY OPTION ▽	COLOR (TPA) ▽	NUMBERS INDICATE CAVITIES OPEN FOR CIRCUITS ▽																																																							
AVAILABLE	NOT APPLICABLE	34576-7093	G	0	G	BLUE	<table border="1"> <tr><td></td><td>54</td><td>53</td><td></td><td></td><td></td><td></td><td>47</td><td>46</td><td>45</td><td>43</td></tr> <tr><td>41</td><td>40</td><td>38</td><td></td><td></td><td></td><td></td><td>33</td><td>32</td><td>31</td><td>30</td><td>29</td></tr> <tr><td>28</td><td>27</td><td>26</td><td>25</td><td>24</td><td></td><td></td><td>20</td><td>19</td><td>18</td><td>16</td><td></td></tr> <tr><td>13</td><td>12</td><td>11</td><td>10</td><td></td><td>8</td><td></td><td></td><td></td><td>3</td><td>2</td><td></td></tr> </table>		54	53					47	46	45	43	41	40	38					33	32	31	30	29	28	27	26	25	24			20	19	18	16		13	12	11	10		8				3	2									
	54	53					47	46	45	43																																																				
41	40	38					33	32	31	30	29																																																			
28	27	26	25	24			20	19	18	16																																																				
13	12	11	10		8				3	2																																																				
AVAILABLE	NOT APPLICABLE	34576-7103	G	0	G	BLUE	<table border="1"> <tr><td>56</td><td>55</td><td></td><td></td><td>52</td><td>51</td><td>50</td><td>49</td><td>48</td><td>47</td><td>45</td><td>43</td></tr> <tr><td>42</td><td>41</td><td></td><td></td><td></td><td></td><td></td><td>35</td><td>34</td><td>33</td><td></td><td>29</td></tr> <tr><td>28</td><td>27</td><td>26</td><td></td><td></td><td></td><td></td><td></td><td></td><td>18</td><td>17</td><td>16</td><td>15</td></tr> <tr><td>14</td><td>13</td><td>12</td><td></td><td></td><td></td><td></td><td></td><td></td><td></td><td>3</td><td>2</td><td>1</td></tr> </table>	56	55			52	51	50	49	48	47	45	43	42	41						35	34	33		29	28	27	26							18	17	16	15	14	13	12								3	2	1					
56	55			52	51	50	49	48	47	45	43																																																			
42	41						35	34	33		29																																																			
28	27	26							18	17	16	15																																																		
14	13	12								3	2	1																																																		
AVAILABLE	NOT APPLICABLE	34576-7113	G	0	G	BLUE	<table border="1"> <tr><td></td><td>54</td><td></td><td></td><td></td><td></td><td></td><td></td><td></td><td>47</td><td>46</td><td>45</td><td>43</td></tr> <tr><td>41</td><td>40</td><td></td><td>38</td><td></td><td></td><td></td><td></td><td></td><td>33</td><td>32</td><td>31</td><td>30</td><td>29</td></tr> <tr><td>28</td><td>27</td><td>26</td><td>25</td><td>24</td><td></td><td></td><td></td><td>20</td><td>19</td><td>18</td><td>16</td><td></td><td></td></tr> <tr><td>13</td><td>12</td><td>11</td><td>10</td><td></td><td>8</td><td></td><td></td><td></td><td></td><td>3</td><td>2</td><td></td><td></td></tr> </table>		54								47	46	45	43	41	40		38						33	32	31	30	29	28	27	26	25	24				20	19	18	16			13	12	11	10		8					3	2		
	54								47	46	45	43																																																		
41	40		38						33	32	31	30	29																																																	
28	27	26	25	24				20	19	18	16																																																			
13	12	11	10		8					3	2																																																			
AVAILABLE	NOT APPLICABLE	34576-7123	G	0	G	BLUE	<table border="1"> <tr><td>56</td><td>55</td><td></td><td></td><td>52</td><td>51</td><td>50</td><td>49</td><td>48</td><td>47</td><td>45</td><td>43</td></tr> <tr><td>42</td><td>41</td><td></td><td></td><td></td><td></td><td></td><td>35</td><td>34</td><td>33</td><td></td><td>29</td></tr> <tr><td>28</td><td>27</td><td>26</td><td></td><td></td><td></td><td></td><td></td><td></td><td>18</td><td>17</td><td>16</td><td>15</td></tr> <tr><td>14</td><td>13</td><td>12</td><td></td><td></td><td></td><td></td><td></td><td></td><td></td><td>3</td><td>2</td><td>1</td></tr> </table>	56	55			52	51	50	49	48	47	45	43	42	41						35	34	33		29	28	27	26							18	17	16	15	14	13	12								3	2	1					
56	55			52	51	50	49	48	47	45	43																																																			
42	41						35	34	33		29																																																			
28	27	26							18	17	16	15																																																		
14	13	12								3	2	1																																																		
AVAILABLE	NOT APPLICABLE	34576-7133	G	9	G	BLUE	<table border="1"> <tr><td>56</td><td>54</td><td>53</td><td>52</td><td></td><td></td><td></td><td></td><td></td><td>47</td><td>46</td><td>45</td><td>43</td></tr> <tr><td>41</td><td>40</td><td>39</td><td>38</td><td></td><td></td><td></td><td></td><td>34</td><td>33</td><td>32</td><td>31</td><td>30</td><td>29</td></tr> <tr><td>28</td><td>27</td><td>26</td><td>25</td><td>24</td><td>23</td><td></td><td></td><td></td><td>20</td><td>19</td><td>18</td><td>16</td><td></td></tr> <tr><td>13</td><td>12</td><td>11</td><td>10</td><td>9</td><td>8</td><td></td><td></td><td></td><td></td><td></td><td>3</td><td>2</td><td></td></tr> </table>	56	54	53	52						47	46	45	43	41	40	39	38					34	33	32	31	30	29	28	27	26	25	24	23				20	19	18	16		13	12	11	10	9	8						3	2	
56	54	53	52						47	46	45	43																																																		
41	40	39	38					34	33	32	31	30	29																																																	
28	27	26	25	24	23				20	19	18	16																																																		
13	12	11	10	9	8						3	2																																																		
AVAILABLE	NOT APPLICABLE	34576-7143	G	9	G	BLUE	<table border="1"> <tr><td>56</td><td>55</td><td>54</td><td>53</td><td>52</td><td>51</td><td></td><td></td><td></td><td>47</td><td>46</td><td>45</td><td>43</td></tr> <tr><td>41</td><td>40</td><td></td><td>38</td><td></td><td></td><td></td><td></td><td>34</td><td>33</td><td>32</td><td>31</td><td>30</td><td>29</td></tr> <tr><td>28</td><td>27</td><td>26</td><td>25</td><td>24</td><td></td><td></td><td></td><td></td><td>20</td><td>19</td><td>18</td><td>16</td><td></td></tr> <tr><td>13</td><td>12</td><td>11</td><td>10</td><td></td><td>8</td><td></td><td></td><td></td><td></td><td></td><td>3</td><td>2</td><td></td></tr> </table>	56	55	54	53	52	51				47	46	45	43	41	40		38					34	33	32	31	30	29	28	27	26	25	24					20	19	18	16		13	12	11	10		8						3	2	
56	55	54	53	52	51				47	46	45	43																																																		
41	40		38					34	33	32	31	30	29																																																	
28	27	26	25	24					20	19	18	16																																																		
13	12	11	10		8						3	2																																																		
AVAILABLE	NOT APPLICABLE	34576-7153	G	9	G	BLUE	<table border="1"> <tr><td>56</td><td>54</td><td>53</td><td>52</td><td></td><td></td><td>49</td><td>47</td><td>46</td><td>45</td><td>43</td></tr> <tr><td>41</td><td>40</td><td>39</td><td>38</td><td></td><td></td><td></td><td>34</td><td>33</td><td>32</td><td>31</td><td>30</td><td>29</td></tr> <tr><td>28</td><td>27</td><td>26</td><td>25</td><td>24</td><td>23</td><td></td><td></td><td></td><td>20</td><td>19</td><td>18</td><td>16</td><td></td></tr> <tr><td>13</td><td>12</td><td>11</td><td>10</td><td>9</td><td>8</td><td></td><td></td><td></td><td></td><td></td><td>3</td><td>2</td><td></td></tr> </table>	56	54	53	52			49	47	46	45	43	41	40	39	38				34	33	32	31	30	29	28	27	26	25	24	23				20	19	18	16		13	12	11	10	9	8						3	2				
56	54	53	52			49	47	46	45	43																																																				
41	40	39	38				34	33	32	31	30	29																																																		
28	27	26	25	24	23				20	19	18	16																																																		
13	12	11	10	9	8						3	2																																																		
AVAILABLE	NOT APPLICABLE	34576-7163	G	0	G	BLUE	<table border="1"> <tr><td></td><td></td><td></td><td>53</td><td></td><td></td><td>49</td><td>47</td><td>46</td><td>45</td><td>44</td></tr> <tr><td></td><td></td><td>40</td><td></td><td>37</td><td>36</td><td>35</td><td>33</td><td></td><td></td><td></td><td></td><td></td><td></td></tr> <tr><td></td><td></td><td>26</td><td></td><td></td><td></td><td></td><td>20</td><td>19</td><td>18</td><td></td><td></td><td></td><td></td></tr> <tr><td>13</td><td>12</td><td></td><td></td><td>9</td><td>7</td><td></td><td></td><td></td><td></td><td></td><td></td><td></td><td></td></tr> </table>				53			49	47	46	45	44			40		37	36	35	33									26					20	19	18					13	12			9	7										
			53			49	47	46	45	44																																																				
		40		37	36	35	33																																																							
		26					20	19	18																																																					
13	12			9	7																																																									
AVAILABLE	NOT APPLICABLE	34576-7173	G	9	G	BLUE	<table border="1"> <tr><td></td><td>55</td><td></td><td></td><td>52</td><td>51</td><td></td><td></td><td>48</td><td>46</td><td>45</td><td>43</td></tr> <tr><td>41</td><td>40</td><td></td><td>38</td><td></td><td></td><td></td><td></td><td>33</td><td>32</td><td>31</td><td>30</td><td>29</td></tr> <tr><td>28</td><td>26</td><td>24</td><td></td><td></td><td></td><td></td><td></td><td>20</td><td>19</td><td>18</td><td>16</td><td>15</td></tr> <tr><td>13</td><td>12</td><td></td><td>10</td><td></td><td></td><td></td><td></td><td></td><td></td><td>3</td><td>2</td><td>1</td></tr> </table>		55			52	51			48	46	45	43	41	40		38					33	32	31	30	29	28	26	24						20	19	18	16	15	13	12		10							3	2	1				
	55			52	51			48	46	45	43																																																			
41	40		38					33	32	31	30	29																																																		
28	26	24						20	19	18	16	15																																																		
13	12		10							3	2	1																																																		

<b>ENTER DESCRIPTION</b> EC NO: UAU2013-1350 DRAWN BY: CHYO APPR: IKOSHY 2013/02/28 2013/02/28 TJSB	QUALITY SYMBOLS ▽=0 ▽=0 ▽=0	GENERAL TOLERANCES (UNLESS SPECIFIED) mm INCH 4 PLACES ±---+ 3 PLACES ±---+ 2 PLACES ±---+ 1 PLACE ±---+ 0 PLACE ±---+	DIMENSION STYLE <b>MM ONLY</b>	SCALE <b>1:1</b>	DESIGN UNITS <b>METRIC</b>	THIRD ANGLE PROJECTION 	
	DRAWN BY: SKRA JENDRANA DATE: 2011/01/25	CHECKED BY:	DATE:	APPROVED BY:	DATE:	TITLE <b>MX123 18/49/56 CKT HRNS CONN ASSY</b>	MATERIAL NO.
	DRAFT WHERE APPLICABLE MUST REMAIN WITHIN DIMENSIONS	SEE BOM TABLE	DOCUMENT NO. <b>SD-34576-001</b>	SHEET NO. <b>14 OF 15</b>	THIS DRAWING CONTAINS INFORMATION THAT IS PROPRIETARY TO MOLEX INCORPORATED AND SHOULD NOT BE USED WITHOUT WRITTEN PERMISSION		
	MOLEX						



20 19 18 17 16 15 14 13 12 11 10 9 8 7 6 5 4 3 2 1

M  
L  
K  
J  
I  
H  
G  
F  
E  
D  
C  
B  
A

STATUS	GM PART #	MATERIAL #	PART/MATERIAL REVISION	WIRE DRESS OPTION	KEY OPTION	COLOR (TPA)	NUMBERS INDICATE CAVITIES OPEN FOR CIRCUITS																																																												
AVAILABLE	NOT APPLICABLE	34576-7183	G	0	G	BLUE	<table border="1"> <tr><td>56</td><td>55</td><td>53</td><td></td><td>49</td><td>48</td><td>47</td><td>46</td><td>44</td><td></td></tr> <tr><td></td><td></td><td>40</td><td>39</td><td>37</td><td>36</td><td>35</td><td>34</td><td>33</td><td>31</td><td>30</td></tr> <tr><td></td><td></td><td></td><td>25</td><td>24</td><td></td><td>22</td><td>21</td><td>20</td><td>19</td><td>18</td></tr> <tr><td></td><td></td><td></td><td></td><td></td><td></td><td></td><td></td><td></td><td>4</td><td>2</td></tr> <tr><td></td><td></td><td></td><td></td><td></td><td></td><td></td><td></td><td></td><td></td><td>1</td></tr> </table>	56	55	53		49	48	47	46	44				40	39	37	36	35	34	33	31	30				25	24		22	21	20	19	18										4	2											1						
56	55	53		49	48	47	46	44																																																											
		40	39	37	36	35	34	33	31	30																																																									
			25	24		22	21	20	19	18																																																									
									4	2																																																									
										1																																																									
<b>F38</b> AVAILABLE	NOT APPLICABLE	34576-7193	G	9	G	BLUE	<table border="1"> <tr><td>56</td><td>54</td><td>53</td><td>52</td><td></td><td></td><td></td><td></td><td>47</td><td>46</td><td>45</td><td>43</td></tr> <tr><td></td><td>41</td><td>40</td><td></td><td>38</td><td></td><td></td><td></td><td>34</td><td>33</td><td>32</td><td>31</td></tr> <tr><td></td><td>28</td><td>27</td><td>26</td><td></td><td>24</td><td></td><td></td><td></td><td>20</td><td>19</td><td>18</td></tr> <tr><td></td><td></td><td>13</td><td>12</td><td></td><td></td><td>10</td><td></td><td></td><td></td><td></td><td>3</td></tr> <tr><td></td><td></td><td></td><td></td><td></td><td></td><td></td><td></td><td></td><td></td><td></td><td>2</td></tr> </table>	56	54	53	52					47	46	45	43		41	40		38				34	33	32	31		28	27	26		24				20	19	18			13	12			10					3												2
56	54	53	52					47	46	45	43																																																								
	41	40		38				34	33	32	31																																																								
	28	27	26		24				20	19	18																																																								
		13	12			10					3																																																								
											2																																																								

<b>ENTER DESCRIPTION</b> EC NO: UAU2013-1350 DRAWN BY: TUB CHKD: 38 APPR: WOSHY 2013/02/26 2013/02/28 DESCRIPTION	QUALITY SYMBOLS		GENERAL TOLERANCES (UNLESS SPECIFIED)		DIMENSION STYLE		SCALE	DESIGN UNITS	THIRD ANGLE PROJECTION	
	▽=0	4 PLACES	mm	INCH	MM ONLY		1:1	METRIC		
	▽=0	3 PLACES			DRAWN BY SKRA JENDRANA		DATE 2011/01/25	TITLE		
	▽=0	2 PLACES			CHECKED BY		DATE	18/49/56 CKT HRNS CONN ASSY <b>molex</b>		
	1 PLACE			APPROVED BY		DATE	MATERIAL NO. 999999999		DOCUMENT NO. SD-34576-001	SHEET NO. 15 OF 15
	0 PLACE			ANGULAR ±			THIS DRAWING CONTAINS INFORMATION THAT IS PROPRIETARY TO MOLEX INCORPORATED AND SHOULD NOT BE USED WITHOUT WRITTEN PERMISSION			