



Chipsmall Limited consists of a professional team with an average of over 10 year of expertise in the distribution of electronic components. Based in Hongkong, we have already established firm and mutual-benefit business relationships with customers from,Europe,America and south Asia,supplying obsolete and hard-to-find components to meet their specific needs.

With the principle of “Quality Parts,Customers Priority,Honest Operation,and Considerate Service”,our business mainly focus on the distribution of electronic components. Line cards we deal with include Microchip,ALPS,ROHM,Xilinx,Pulse,ON,Everlight and Freescale. Main products comprise IC,Modules,Potentiometer,IC Socket,Relay,Connector.Our parts cover such applications as commercial,industrial, and automotives areas.

We are looking forward to setting up business relationship with you and hope to provide you with the best service and solution. Let us make a better world for our industry!



Contact us

Tel: +86-755-8981 8866 Fax: +86-755-8427 6832

Email & Skype: info@chipsmall.com Web: www.chipsmall.com

Address: A1208, Overseas Decoration Building, #122 Zhenhua RD., Futian, Shenzhen, China



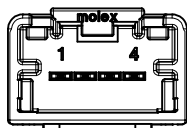

4 CIRCUIT VERTICAL HEADER
POLARIZATION OPTION A

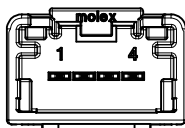

4 CIRCUIT VERTICAL HEADER
POLARIZATION OPTION B

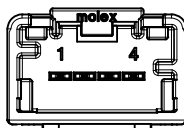

4 CIRCUIT VERTICAL HEADER
POLARIZATION OPTION C

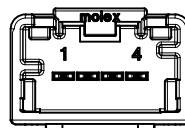

4 CIRCUIT VERTICAL HEADER
POLARIZATION OPTION D

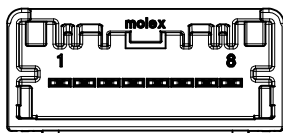

8 CIRCUIT USCAR VERTICAL HEADER
POLARIZATION OPTION A

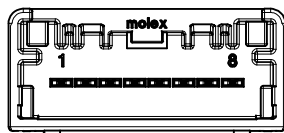

8 CIRCUIT USCAR VERTICAL HEADER
POLARIZATION OPTION B

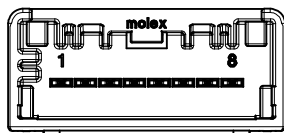

8 CIRCUIT USCAR VERTICAL HEADER
POLARIZATION OPTION C

NOTES: VALID UNLESS OTHERWISE SPECIFIED

1. GENERAL:
 - a. APPLICATION SPECIFICATION SEE: AS-34791-020
 - b. PRODUCT SPECIFICATION SEE: PS-34791-020
 - c. PACKAGING SPECIFICATION PER MOLEX DRAWING: SEE CHART
 - d. SOLDERABILITY PER SMES-152
 - e. PARTS MUST BE IN COMPLIANCE TO MOLEX CHEMICAL SUBSTANCES FOR PRODUCTS AND PACKAGING SPECIFICATION: QEHS-699000-300
 - f. DATA MUST BE SUBMITTED UNDER THE MOLEX PART NUMBER TO IMDS (COMPANY ID#13255)
 - g. FLAMMABILITY REQUIREMENT: PER ISO3795 OR GM3191
 - h. VISUAL DEFECTS SHALL MEET COSMETIC STANDARD PS-45499-002 (Class B)
2. DESIGN - MATERIALS:
 - a. SHROUD (PLASTIC HOUSING): SPS 30% GF, 20% REGRIND MAX PER WEIGHT
 - b. BLADES:
 - BASE METAL: C260 BRASS
 - PLATING REQUIREMENTS:
 - TIN OVER NICKEL:
 - UNDERPLATING:
 - OVERALL NICKEL
 - OVERPLATING:
 - OVERALL TIN
3. DESIGN - GEOMETRY:
 - a. THIS IS A 100% CAD GENERATED PART. THE CAD MATHEMATICAL DATA IS THE MASTER FOR THIS PART. FOR DIMENSIONAL OR ANY INFORMATION NOT SHOWN ON THIS DRAWING, ANALYZE THE CAD MODEL.
 - b. GEOMETRIC DIMENSIONS AND TOLERANCES PER ASME Y14.5M - 2009
 - c. GENERAL TOLERANCES:
 - LINEAR: SEE TITLE BLOCK
 - ANGULAR: +3°
 - d. EDGES AND UNDIMENSIONED DETAILS PER ISO13715
 - e. CORNERS SHOWN AS SHARP TO BE R 0.1 MAX
 - f. LETTERING SHALL BE 0.10 MAX RAISED. THIS INCLUDES RECYCLING CODE, PLANT AND CAVITY ID, VENDOR ID, AND CIRCUIT ID.

MINI50 VERTICAL HEADER ASSEMBLIES

MATERIAL NUMBER			CONFIGURATION	CIRCUIT	POL	COLOR	BLADE PLATING	MATING COMPONENT	
TAPE & REEL PACKAGING PK-47799-0001	TUBE PACKAGING PK-31301-688	TRAY PACKAGING PK-31301-440						UN-BRIDGED	BRIDGED
34792-8040	34792-9040	34792-0040	USCAR	4	A	BLACK	TIN OVER NICKEL	34791-0040	34791-0140
34792-8041	34792-9041	34792-0041	USCAR	4	B	GRAY	TIN OVER NICKEL	34791-0041	34791-0141
34792-8042	34792-9042	34792-0042	USCAR	4	C	DARK GRAY	TIN OVER NICKEL	34791-0042	34791-0142
34792-8043	34792-9043	34792-0043	USCAR	4	D	GREEN	TIN OVER NICKEL	34791-0043	34791-0143
34792-8080	34792-9080	34792-0080	USCAR	8	A	BLACK	TIN OVER NICKEL	34791-0080	34791-0180
34792-8081	34792-9081	34792-0081	USCAR	8	B	GRAY	TIN OVER NICKEL	34791-0081	34791-0181
34792-8082	34792-9082	34792-0082	USCAR	8	C	DARK GRAY	TIN OVER NICKEL	34791-0082	34791-0182
N/A	N/A	34792-2081	USCAR	8	B	GRAY	TIN OVER NICKEL	34791-0082	34791-0182

LAST BALLOON ON DRAWING:
⑬
DELETED BALLOONS:
⑭

DARK GRAY POL C EC NO: UAU2017-1148 DRAWN BY: MACHUGA 2017/03/29 CHYK: APPR: RBALMAN 2017/06/20 REV DESCRIPTION	QUALITY SYMBOLS	GENERAL TOLERANCES (UNLESS SPECIFIED)	DIMENSION STYLE	SCALE	DESIGN UNITS	THIRD ANGLE PROJECTION
	▽=0	mm INCH	MM ONLY	5:1	METRIC	☉
	▽=0	4 PLACES ± --- ± ---	DRAWN BY DATE			
	▽=0	3 PLACES ± --- ± ---	JDUNAJ 2010/06/24			
	2 PLACES ± 0.1 ± ---	CHECKED BY DATE				MINI 50 SINGLE ROW VERTICAL HEADER ASSEMBLY SALES DRAWING
	1 PLACE ± 0.2 ± ---	BDICK 2010/06/24				
	ANGULAR ± ---°	APPROVED BY DATE				MOLEX INCORPORATED
		SMARCEAU 2011/11/21				
	DRAFT WHERE APPLICABLE MUST REMAIN WITHIN DIMENSIONS	MATERIAL NO.	SIZE	DOCUMENT NO.		SHEET NO.
		SEE TABLE	D	SD-34792-001		1 OF 3
		THIS DRAWING CONTAINS INFORMATION THAT IS PROPRIETARY TO MOLEX INCORPORATED AND SHOULD NOT BE USED WITHOUT WRITTEN PERMISSION				

4 CKT VERTICAL HEADER

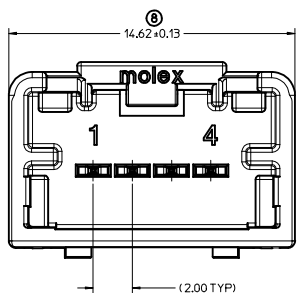
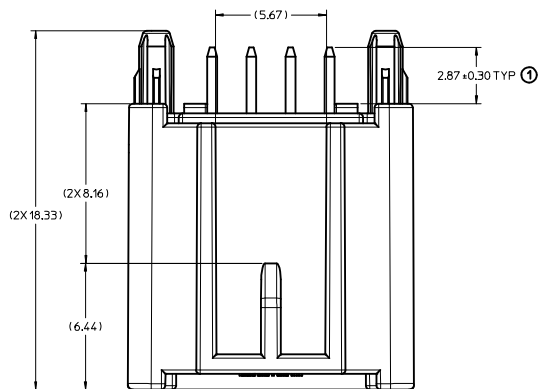

HEADER TO PCB FLUSH MOUNT

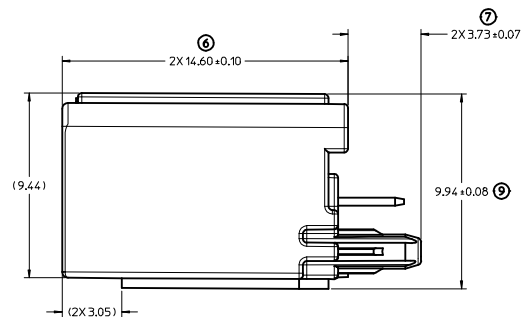
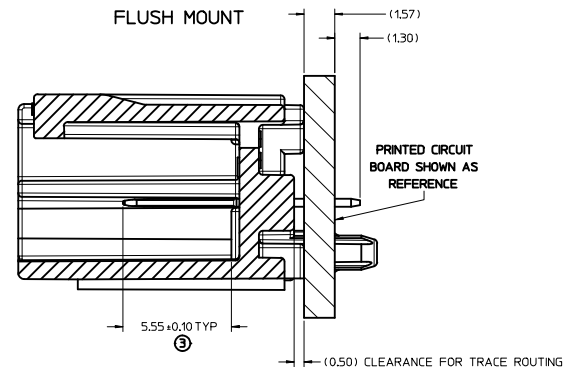

PCB LAYOUT CONNECTOR MATE SIDE

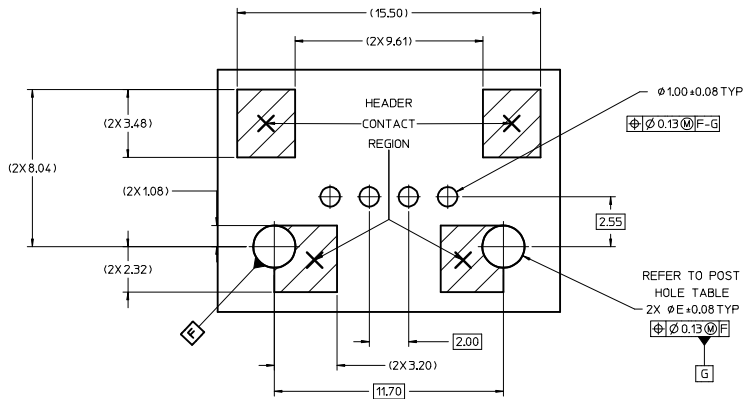

POST HOLE TABLE

	DIM 'E'
PRESS FIT	2.15
DROP IN	2.55

DARK GRAY POL C EC NO: UAU2017-1148 CHKD: WACHUGA APPR: RBAUMAN 2017/03/29 2017/06/20	QUALITY SYMBOLS	GENERAL TOLERANCES (UNLESS SPECIFIED)	DIMENSION STYLE	SCALE	DESIGN UNITS	THIRD ANGLE PROJECTION
	▽=0	mm INCH	MM ONLY	8:1	METRIC	THIRD ANGLE PROJECTION
	▽=0	4 PLACES ± --- ± ---	DRAWN BY	DATE	TITLE	
	▽=0	3 PLACES ± --- ± ---	JDUNA J	2010/06/24	MINI 50 SINGLE ROW VERTICAL HEADER ASSEMBLY SALES DRAWING	
	2 PLACES ± 0.1 ± ---	CHECKED BY	DATE			
	1 PLACE ± 0.2 ± ---	BDICK	2010/06/24			
	ANGULAR ± --- °	APPROVED BY	DATE			
		SMARCEAU	2011/11/21			
	DRAFT WHERE APPLICABLE MUST REMAIN WITHIN DIMENSIONS	MATERIAL NO.	DOCUMENT NO.			
		SEE TABLE	SD-34792-001			
		THIS DRAWING CONTAINS INFORMATION THAT IS PROPRIETARY TO MOLEX INCORPORATED AND SHOULD NOT BE USED WITHOUT WRITTEN PERMISSION				

8 CKT VERTICAL HEADER

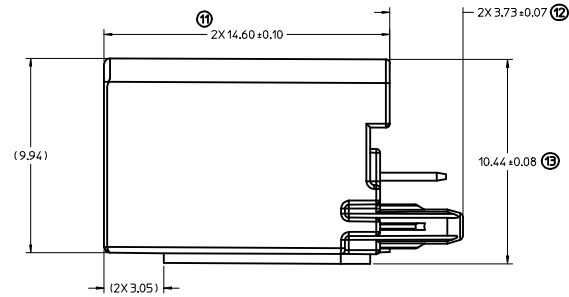
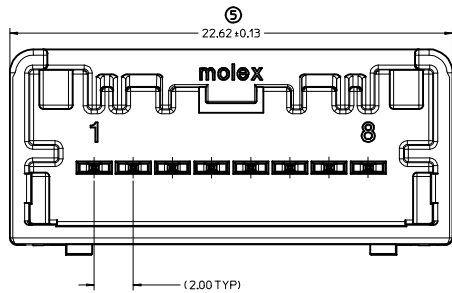
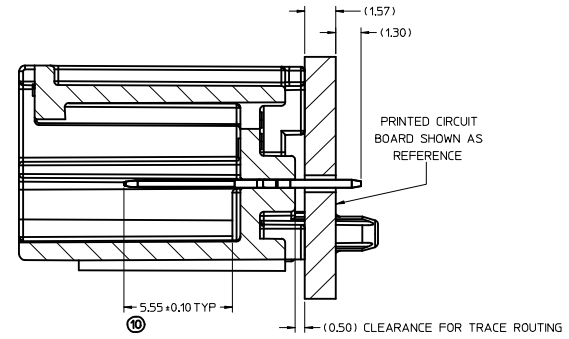
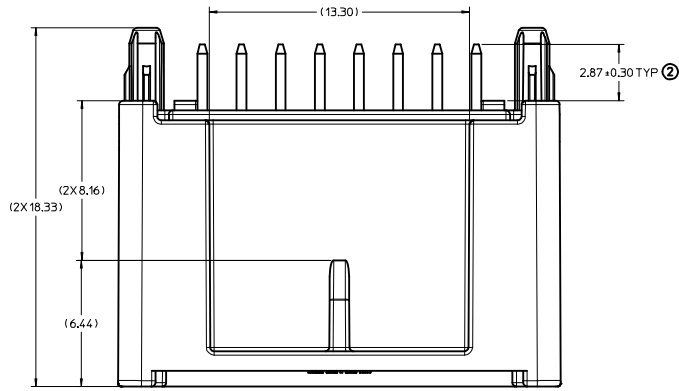

PCB LAYOUT CONNECTOR MATE SIDE

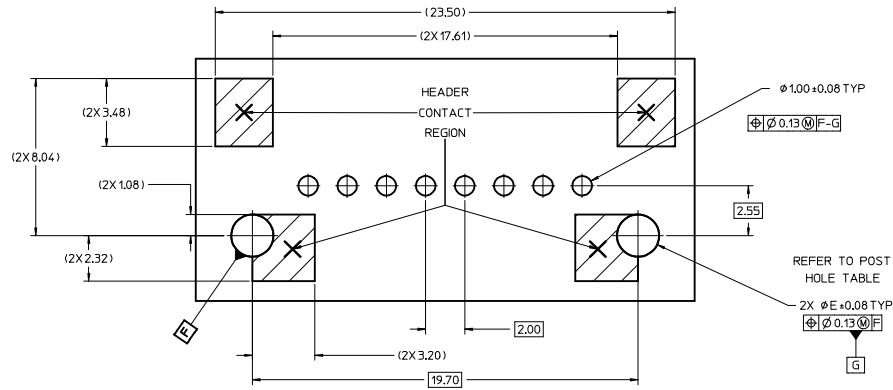

POST HOLE TABLE

	DIM 'E'
PRESS FIT	2.15
DROP IN	2.55

DARK GRAY POL C EC NO: UAU2017-1148 CHKD: DRWIN/TMACHUGA 2017/03/29 APPR: RBAUMAN 2017/06/20	QUALITY SYMBOLS	GENERAL TOLERANCES (UNLESS SPECIFIED)	DIMENSION STYLE	SCALE	DESIGN UNITS	THIRD ANGLE PROJECTION
	▽=0	mm INCH	MM ONLY	8:1	METRIC	
	▽=0	4 PLACES ± --- ± ---	DRAWN BY	DATE	TITLE	
	▽=0	3 PLACES ± --- ± ---	JDUNA J	2010/06/24	MINI 50 SINGLE ROW VERTICAL HEADER ASSEMBLY SALES DRAWING	
	2 PLACES ± 0.1 ± ---	CHECKED BY	DATE			
	1 PLACE ± 0.2 ± ---	BDICK	2010/06/24			
	0 PLACE ± ±	APPROVED BY	DATE			
	ANGULAR ± --- °	SMARCEAU	2011/11/21			
	DRAFT WHERE APPLICABLE MUST REMAIN WITHIN DIMENSIONS	MATERIAL NO.	DOCUMENT NO.	SEE CHART	SD-34792-001	SHEET NO. 3 OF 3
		THIS DRAWING CONTAINS INFORMATION THAT IS PROPRIETARY TO MOLEX INCORPORATED AND SHOULD NOT BE USED WITHOUT WRITTEN PERMISSION				