



Chipsmall Limited consists of a professional team with an average of over 10 year of expertise in the distribution of electronic components. Based in Hongkong, we have already established firm and mutual-benefit business relationships with customers from,Europe,America and south Asia,supplying obsolete and hard-to-find components to meet their specific needs.

With the principle of “Quality Parts,Customers Priority,Honest Operation,and Considerate Service”,our business mainly focus on the distribution of electronic components. Line cards we deal with include Microchip,ALPS,ROHM,Xilinx,Pulse,ON,Everlight and Freescale. Main products comprise IC,Modules,Potentiometer,IC Socket,Relay,Connector.Our parts cover such applications as commercial,industrial, and automotives areas.

We are looking forward to setting up business relationship with you and hope to provide you with the best service and solution. Let us make a better world for our industry!



Contact us

Tel: +86-755-8981 8866 Fax: +86-755-8427 6832

Email & Skype: info@chipsmall.com Web: www.chipsmall.com

Address: A1208, Overseas Decoration Building, #122 Zhenhua RD., Futian, Shenzhen, China



TABLE OF CONTENTS

SHEET NO.	SHEET DESCRIPTION
1	NOTES
2	1x2 RECEPTACLE SEALED ASSEMBLY KEYING CONFIGURATIONS
3	1x3 RECEPTACLE SEALED ASSEMBLY KEYING CONFIGURATIONS
4	RECEPTACLE SEALED ASSEMBLY
5	1x2 RECEPTACLE SEALED ASSEMBLY BOM SHEET 1
6	1x3 RECEPTACLE SEALED ASSEMBLY BOM SHEET 1

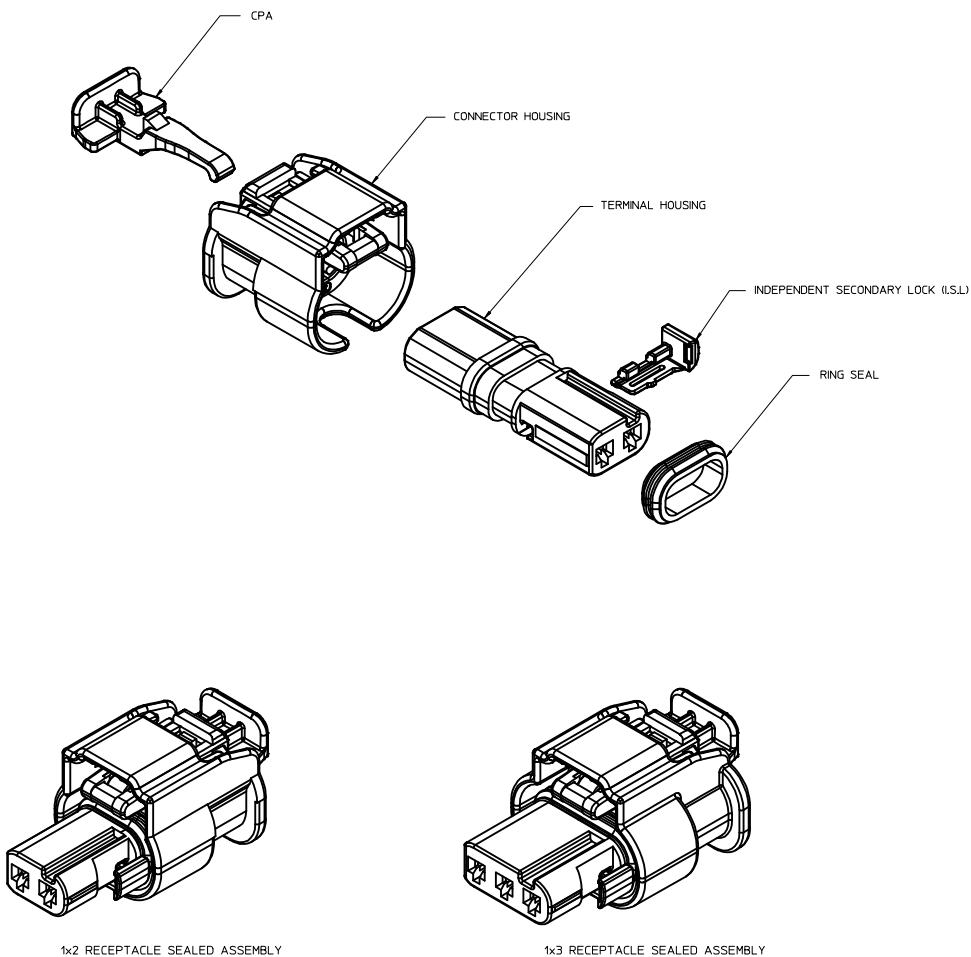

NOTES: VALID UNLESS OTHERWISE SPECIFIED

1. GENERAL:
a. APPLICATION SPECIFICATION SEE: AS-34900-0001
 CONTAINS: PRODUCT INTRODUCTION, PRODUCT SUMMARY, CONNECTOR ASSEMBLY, PACKAGING INFORMATION, CONNECTOR MATING, SERVICE INSTRUCTIONS, ELECTRICAL CONTINUITY CHECKING, CRIMPING, AND TROUBLESHOOTING.
b. PRODUCT SPECIFICATION SEE: PS-34900-0001
 CONTAINS: PRODUCT INTRODUCTION, PRODUCT SUMMARY, RATINGS (CURRENT, TEMPERATURE, SEALING, AND FLAMMABILITY), AND PRODUCT VALIDATION.
c. PACKAGING SPECIFICATION PER MOLEX DRAWING: PK-31301-898
d. PARTS MUST BE IN COMPLIANCE TO MOLEX CHEMICAL SUBSTANCES FOR PRODUCTS AND PACKAGING SPECIFICATION: ES-40000-5016
e. DATA MUST BE SUBMITTED UNDER THE MOLEX PART NUMBER TO IMDS (COMPANY ID#13255)
f. DESIGNED TO MATE WITH DEVICE CONNECTION AS SPECIFIED IN BOM CHART. USCAR DRAWINGS AND MODELS ARE AVAILABLE AT <http://ewcapuscarteams.org/>.

2. DESIGN - MATERIALS:
a. SEE BOM TABLE

3. DESIGN - GEOMETRY:
a. THIS IS A 100% CAD GENERATED PART. THE CAD MATHEMATICAL DATA IS THE MASTER FOR THIS PART. FOR DIMENSIONAL OR ANY INFORMATION NOT SHOWN ON THIS DRAWING, ANALYZE THE CAD MODEL.
b. GEOMETRIC DIMENSIONS AND TOLERANCES PER ASME Y14.5M - 1994
c. EDGES AND UNDIMENSIONED DETAILS PER ISO13715
d. CORNERS SHOWN AS SHARP TO BE R 0.2 MAX.
e. LETTERING SHALL BE 0.15 MAX RAISED IN 0.25 MAX RECESS PAD. THIS INCLUDES RECYCLING CODE, CAVITY ID, VENDOR IDENTIFICATION, AND CUSTOMER MATERIAL NUMBER.
f. VISUAL DEFECTS SHALL MEET COSMETIC STANDARD PS-45499-002 (Class B)
g. LASER MARKING:
 1. PART NUMBER
 2. DAY OF THE YEAR
 3. SHIFT
 4. YEAR

REV	DESCRIPTION
C	34900-3127 RELEASED AS SALEABLE
B	PRIMARY KEYS (A,B) MOVED TO SALEABLE
A10	ADDED 1X3 SEVERE VIBRATION PART NUMBER
A9	1X2 AND 1X3 PART # STATUS UPDATED DIMENSION 2 UPDATED
A8	1X2 PART # UPDATED TO *TOOLED BUT NOT VALIDATED*
A7	1X2 PART # UPDATED TO *TOOLED BUT NOT VALIDATED*
A6	ADDED NEW PART NUMBERS FOR LATCH IMPROVEMENT
A5	BOM CORRECTIONS AND UPDATES
A4	BOM CORRECTIONS AND UPDATES
A3	1x2, 1x3 NON-SIR OK TO TOOL
A2	MINOR BOM CORRECTIONS
A1	ADDED COMPONENTS TO BOM
A	ADDED BLACK PART NUMBERS AND MINOR BOM UPDATES
3	ADDED 1x3
2	MINOR BOM CORRECTIONS
1	INITIAL RELEASE

ENTER DESCRIPTION EC NO: VAL2017-0205 DRWN: PATE01 2016/09/07 CHKD: APPR: KOLEKSKI 2016/09/13 REV:	QUALITY SYMBOLS ∇=0 ∇=0 ∇=0	GENERAL TOLERANCES (UNLESS SPECIFIED) <table border="1"> <thead> <tr> <th></th> <th>mm</th> <th>INCH</th> </tr> </thead> <tbody> <tr> <td>4 PLACES</td> <td>±.005</td> <td>±.0005</td> </tr> <tr> <td>3 PLACES</td> <td>±.010</td> <td>±.0005</td> </tr> <tr> <td>2 PLACES</td> <td>±.020</td> <td>±.0005</td> </tr> <tr> <td>1 PLACE</td> <td>±.050</td> <td>±.0020</td> </tr> <tr> <td>0 PLACE</td> <td>±.050</td> <td>±.0020</td> </tr> </tbody> </table> ANGULAR ± 3 ° DRAFT WHERE APPLICABLE MUST REMAIN WITHIN DIMENSIONS		mm	INCH	4 PLACES	±.005	±.0005	3 PLACES	±.010	±.0005	2 PLACES	±.020	±.0005	1 PLACE	±.050	±.0020	0 PLACE	±.050	±.0020	DIMENSION STYLE MM ONLY DRAWN BY: MYANSLAMBROU 2012/02/15 CHECKED BY: DATE APPROVED BY: GGA 2012/12/13 DATE:	SCALE: 4:1 DESIGN UNITS: METRIC THIRD ANGLE PROJECTION	TITLE: 12MM 1X2, 1X3 RECP. SEALED ASSEMBLY CABLE SEAL molex DOCUMENT NO: SD-34900-0001 SHEET NO: 1 OF 6
		mm	INCH																				
	4 PLACES	±.005	±.0005																				
	3 PLACES	±.010	±.0005																				
2 PLACES	±.020	±.0005																					
1 PLACE	±.050	±.0020																					
0 PLACE	±.050	±.0020																					
THIS DRAWING CONTAINS INFORMATION THAT IS PROPRIETARY TO MOLEX INCORPORATED AND SHOULD NOT BE USED WITHOUT WRITTEN PERMISSION																							
SIZE: D																							
MATERIAL NO:																							

1x2 RECEPTACLE SEALED ASSEMBLY KEYING CONFIGURATIONS. FOR PART NUMBERS REFER TO BOM SHEET.

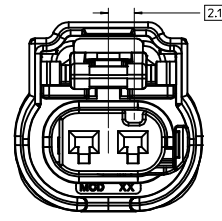

KEYING OPTION A

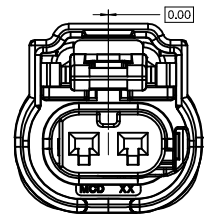

KEYING OPTION B

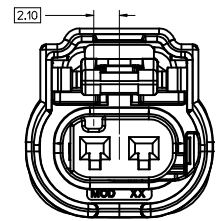

KEYING OPTION C

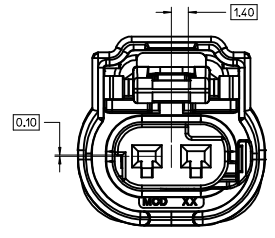

KEYING OPTION E

ENTER DESCRIPTION IEC NO: UAU2017-0205 DRAWN/PATE01 2016/09/07 CHKD: APPR:KIEKOSKI 2016/09/13	QUALITY SYMBOLS ▽=0 ▽=0 ▽=0	GENERAL TOLERANCES (UNLESS SPECIFIED)		DIMENSION STYLE MM ONLY	SCALE 5:1	DESIGN UNITS METRIC	THIRD ANGLE PROJECTION	
		4 PLACES ± --- ± --- 3 PLACES ± --- ± --- 2 PLACES ± 0.10 ± --- 1 PLACE ± 0.20 ± --- 0 PLACE ± 0.50 ±	mm INCH	DRAWN BY MYANSLAMBROU	DATE 2012/02/15	CHECKED BY	DATE	TITLE 12MM 1X2. 1X3 RECPCT. SEALED ASSEMBLY CABLE SEAL
		ANGULAR ± 3 ° DRAFT WHERE APPLICABLE MUST REMAIN WITHIN DIMENSIONS		APPROVED BY GGA	DATE 2012/12/13	MATERIAL NO. SEE BOM	DOCUMENT NO. SD-34900-2001	SHEET NO. 2 OF 6
		THIS DRAWING CONTAINS INFORMATION THAT IS PROPRIETARY TO MOLEX INCORPORATED AND SHOULD NOT BE USED WITHOUT WRITTEN PERMISSION						

1x3 RECEPTACLE SEALED ASSEMBLY KEYING CONFIGURATIONS. FOR PART NUMBERS REFER TO BOM SHEET.

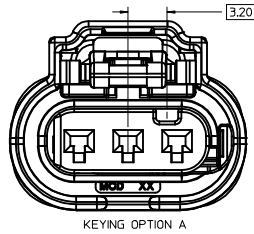

KEYING OPTION A

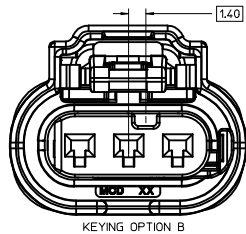

KEYING OPTION B

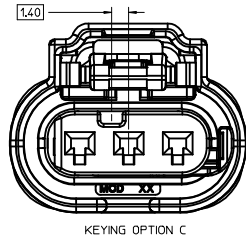

KEYING OPTION C

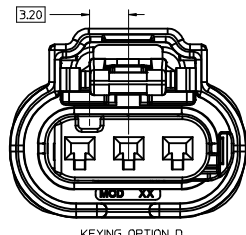

KEYING OPTION D

ENTER DESCRIPTION IEC NO. UAU2017-0205 DRAWN/PATE01 2016/09/07 CHKD: APPR:KIEKSKI 2016/09/13	QUALITY SYMBOLS ▽=0 ▽=0 ▽=0	GENERAL TOLERANCES (UNLESS SPECIFIED)		DIMENSION STYLE MM ONLY	SCALE 5:1	DESIGN UNITS METRIC	THIRD ANGLE PROJECTION		
		4 PLACES ± --- ± --- 3 PLACES ± --- ± --- 2 PLACES ± 0.10 ± --- 1 PLACE ± 0.20 ± --- 0 PLACE ± 0.50 ±	mm INCH	DRAWN BY MYANSLAMBROU	DATE 2012/02/15	CHECKED BY DATE	TITLE 12MM 1X2, 1X3 RECPT. SEALED ASSEMBLY CABLE SEAL		
		ANGULAR ± 3 ° DRAFT WHERE APPLICABLE MUST REMAIN WITHIN DIMENSIONS		APPROVED BY GGA	DATE 2012/12/13	MATERIAL NO. SEE BOM			DOCUMENT NO. SD-34900-2001
				SIZE D	THIS DRAWING CONTAINS INFORMATION THAT IS PROPRIETARY TO MOLEX INCORPORATED AND SHOULD NOT BE USED WITHOUT WRITTEN PERMISSION				SHEET NO. 3 OF 6

1X2 RECEPTACLE SEALED ASSEMBLY BOM SHEET 1

KEYING OPTION E, BLACK	34900-2123	-40 TO 155	4			CHB		E	TOOLED BUT NOT VALIDATED	1	2	3
KEYING OPTION C, BLACK	34900-2122	-40 TO 155	4			CHB		C	TOOLED BUT NOT VALIDATED	1	2	3
KEYING OPTION B, BLACK	34900-2121	-40 TO 155	4			CHB	B		SALEABLE	1	2	3
KEYING OPTION A, BLACK	34900-2120	-40 TO 155	4			CHB	A		SALEABLE	1	2	3
KEYING OPTION E, YELLOW	34900-2104	-40 TO 125	2			CHY		E	TOOLED BUT NOT VALIDATED	1	2	3
KEYING OPTION C, YELLOW	34900-2103	-40 TO 125	2			CHY		C	TOOLED BUT NOT VALIDATED	1	2	3
KEYING OPTION B, YELLOW	34900-2102	-40 TO 125	2			CHY	B		SALEABLE	1	2	3
KEYING OPTION A, YELLOW	34900-2101	-40 TO 125	2			CHY	A		SALEABLE	1	2	3
KEYING OPTION E, BLACK	34900-2023	-40 TO 125	2			CHB		E	OBSOLETE	1	2	3
KEYING OPTION C, BLACK	34900-2022	-40 TO 125	2			CHB		C	OBSOLETE	1	2	3
KEYING OPTION B, BLACK	34900-2021	-40 TO 125	2			CHB	B		OBSOLETE	1	2	3
KEYING OPTION A, BLACK	34900-2020	-40 TO 125	2			CHB	A		OBSOLETE	1	2	3
KEYING OPTION E, YELLOW	34900-2004	-40 TO 125	2			CHY		E	OBSOLETE	1	2	3
KEYING OPTION C, YELLOW	34900-2003	-40 TO 125	2			CHY		C	OBSOLETE	1	2	3
KEYING OPTION B, YELLOW	34900-2002	-40 TO 125	2			CHY	B		SALEABLE	1	2	3
KEYING OPTION A, YELLOW	34900-2001	-40 TO 125	2			CHY	A		SALEABLE	1	2	3
ASSEMBLY DESCRIPTION	PART NUMBER	OPERATING TEMPERATURE	VIBRATION CLASS PER GMW3191 DEC. 2007			A	B	C	E	STATUS	COMMENTS	DESIGNED TO MATE WITH DEVICE CONNECTION

DESCRIPTION	COLOR	MATERIAL	COMMENTS
RING SEAL	BURNT RED	INHERENTLY LUBRICATED SILICONE	
ISL	NATURAL	SPS/NYLON GF20	
CPA	RED	FBT GF30	
TERMINAL HOUSING KEYING OPTION E	STONE GRAY	SPS/NYLON GF20	
TERMINAL HOUSING KEYING OPTION C	DARK GRAY	SPS/NYLON GF20	
TERMINAL HOUSING KEYING OPTION B	LT. GRAY	SPS/NYLON GF20	
TERMINAL HOUSING KEYING OPTION A	BLACK	SPS/NYLON GF20	
CONNECTOR HOUSING	BLACK	SPS/NYLON GF20	UPDATED LATCH
CONNECTOR HOUSING	YELLOW	SPS/NYLON GF20	UPDATED LATCH
CONNECTOR HOUSING	BLACK	SPS/NYLON GF20	
CONNECTOR HOUSING	YELLOW	SPS/NYLON GF20	

DESCRIPTION	COLOR	MATERIAL	COMMENTS
BOM/APPLICABLE COMPONENTS TABLE			

ABBREVIATION	COMPONENT
CHY	CONNECTOR HOUSING YELLOW
CHB	CONNECTOR HOUSING BLACK
A	TERMINAL HOUSING KEY A
B	TERMINAL HOUSING KEY B
C	TERMINAL HOUSING KEY C
E	TERMINAL HOUSING KEY E
CPA	CPA
ISL	ISL
R	RING SEAL
1	USCAR INTERFACE 120-5-002-1-Z01 SEE NOTE 1F FOR WEBSITE
2	MOLEX INLINE BLADE CONNECTOR E-34899-2001
3	USCAR INTERFACE 120-5-002-1-Z02 SEE NOTE 1F FOR WEBSITE

ENTER DESCRIPTION EC NO: UAU2017-0205 DRAWN: PATE01 2016/09/07 CHKD: APPR: K0EKO SKI 2016/09/13 REV	QUALITY SYMBOLS ∇=0 ∇=0 ∇=0	GENERAL TOLERANCES (UNLESS SPECIFIED) 4 PLACES ± --- INCH 3 PLACES ± --- INCH 2 PLACES ± 0.10 1 PLACE ± 0.20 0 PLACE ± 0.50 ANGULAR ± 3 ° DRAFT WHERE APPLICABLE MUST REMAIN WITHIN DIMENSIONS	DIMENSION STYLE MM ONLY	SCALE 2:1 DESIGN UNITS METRIC THIRD ANGLE PROJECTION	DRAWN BY DATE MYANSLAMBROU 2012/02/15	TITLE 12MM 1X2. 1X3 RECPT. SEALED ASSEMBLY CABLE SEAL molex
					CHECKED BY DATE GGA 2012/12/13	

THIS DRAWING CONTAINS INFORMATION THAT IS PROPRIETARY TO MOLEX INCORPORATED AND SHOULD NOT BE USED WITHOUT WRITTEN PERMISSION

TABLE OF CONTENTS

SHEET NO.	SHEET DESCRIPTION
1	NOTES
2	1x2 BLADE SEALED ASSEMBLY KEYING CONFIGURATIONS
3	1x3 BLADE SEALED ASSEMBLY KEYING CONFIGURATIONS
4	CLIP-SLOT CONFIGURATIONS
5	BLADE SEALED ASSEMBLY
6	CONNECTION SYSTEM PACKAGING
8	WIRE DRESS COVER INTERFACE OPTIONS
8	1x2 BLADE SEALED ASSEMBLY BOM INTERFACE OPTION 1
9	1x2 BLADE SEALED ASSEMBLY BOM INTERFACE OPTION 2
8	1x3 BLADE SEALED ASSEMBLY BOM INTERFACE OPTION 1
9	1x3 BLADE SEALED ASSEMBLY BOM INTERFACE OPTION 2

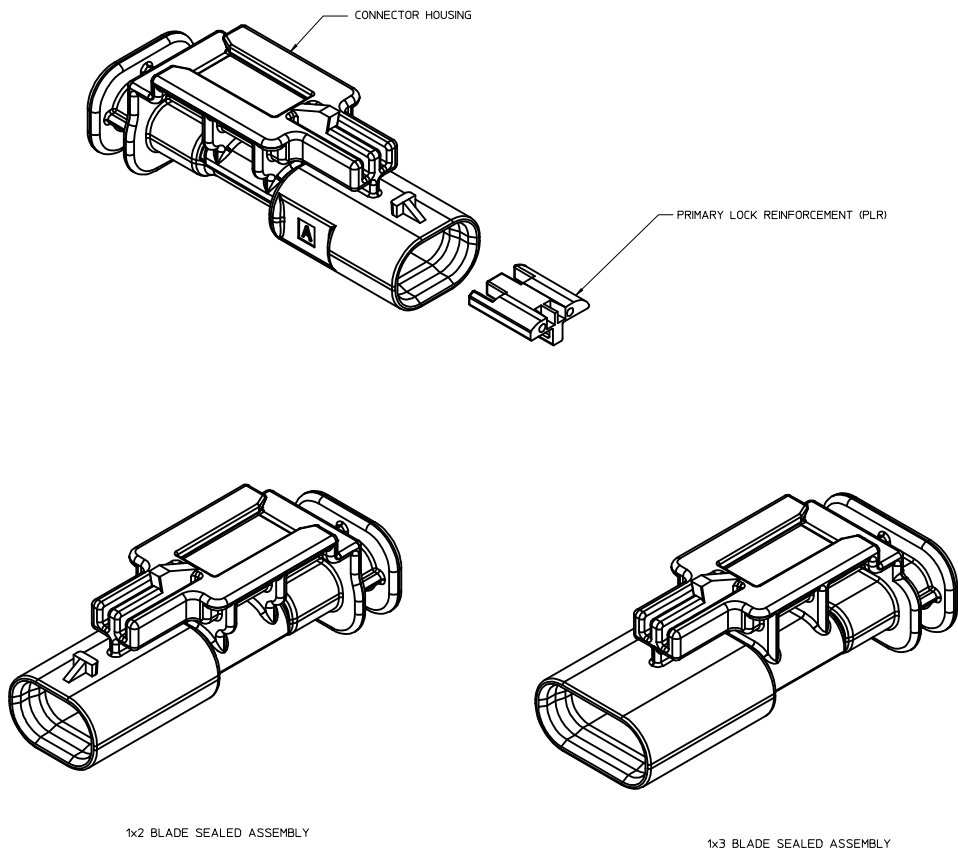

NOTES: VALID UNLESS OTHERWISE SPECIFIED

1. GENERAL:
 - a. APPLICATION SPECIFICATION SEE: AS-34900-0001
CONTAINS: PRODUCT INTRODUCTION, PRODUCT SUMMARY, CONNECTOR ASSEMBLY, PACKAGING INFORMATION, CONNECTOR MATING, SERVICE INSTRUCTIONS, ELECTRICAL CONTINUITY CHECKING, CRIMPING, AND TROUBLESHOOTING.
 - b. PRODUCT SPECIFICATION SEE: PS-34900-0001
CONTAINS: PRODUCT INTRODUCTION, PRODUCT SUMMARY, RATINGS (CURRENT, TEMPERATURE, SEALING, AND FLAMMABILITY), AND PRODUCT VALIDATION.
 - c. PACKAGING SPECIFICATION PER MOLEX DRAWING: PK-31301-898
 - d. PARTS MUST BE IN COMPLIANCE TO MOLEX CHEMICAL SUBSTANCES FOR PRODUCTS AND PACKAGING SPECIFICATION: ES-40000-5016
 - e. DATA MUST BE SUBMITTED UNDER THE MOLEX PART NUMBER TO IMDS (COMPANY ID#13255)
2. DESIGN - MATERIALS:
 - a. SEE BOM TABLE
3. DESIGN - GEOMETRY:
 - a. THIS IS A 100% CAD GENERATED PART. THE CAD MATHEMATICAL DATA IS THE MASTER FOR THIS PART. FOR DIMENSIONAL OR ANY INFORMATION NOT SHOWN ON THIS DRAWING, ANALYZE THE CAD MODEL.
 - b. GEOMETRIC DIMENSIONS AND TOLERANCES PER ASME Y14.5M - 1994
 - c. EDGES AND UNDIMENSIONED DETAILS PER ISO13715
 - d. CORNERS SHOWN AS SHARP TO BE R 0.2 MAX.
 - e. LETTERING SHALL BE 0.15 MAX RAISED IN 0.25 MAX RECESS PAD. THIS INCLUDES RECYCLING CODE, CAVITY ID, VENDOR IDENTIFICATION.
 - f. VISUAL DEFECTS SHALL MEET COSMETIC STANDARD PS-45499-002 (Class B)
- g. LASER MARKING:
 1. PART NUMBER
 2. DAY OF THE YEAR
 3. SHIFT
 4. YEAR

INSPECTION NUMBER LOG
LAST NUMBER USED:
ADDED:
REMOVED:

REV	DESCRIPTION
A14	CORRECTED CHARTED DIMENSION 3 FOR 1x3 11MM CLIP-SLOT
A13	1x3 KEY A&B SALEABLE (NON 40G)
A12	1x2 KEYS A&B W/ WDC SALEABLE
A11	CORRECTED REVISION LOG
A10	1x2,1x3 WIRE DRESS FEATURES OK TO TOOL
A9	1x2,1x3 PART # STATUS UPDATED
A8	1x2 40G CLIP-SLOT OK TO TOOL
A7	1x2,1x3 PART # UPDATED TO "TOOLED BUT NOT VALIDATED"
A6	ADDED 40G CLIP-SLOT PART NUMBERS
A5	BOM CORRECTIONS AND UPDATES
A4	BOM CORRECTIONS AND UPDATES
A3	1x2, 1x3 NON-SIR PART# OK TO TOOL
A2	ADDED 1x3 11mm CLIP-SLOT PART #
A	ADDED BLACK PART# AND MINOR BOM UPDATES
6	ADDED CLIP SLOT CONFIGURATIONS
5	1x3 BOM UPDATED
4	1x3 INLINE ASSY VIEWS ADDED
3	MINOR BOM CORRECTIONS
2	UPDATED PACKAGING DIMENSIONS
1	INITIAL RELEASE

1x3 VIEWS ADDED EC NO: UAU2016-1535 DRAWING: ANBR012016/04/15 CHKD: APPR: IKOSHY 2016/04/15	QUALITY SYMBOLS	GENERAL TOLERANCES (UNLESS SPECIFIED):	DIMENSION STYLE	SCALE	DESIGN UNITS	THIRD ANGLE PROJECTION
	▽=0	4 PLACES ±.004 ±.004	MM ONLY	4:1	METRIC	
	▽=0	3 PLACES ±.004 ±.004	DRAWN BY: SKRAJENDRANA 2013/11/06			
	▽=0	2 PLACES ±.010 ±.010	CHECKED BY: DATE			
	1 PLACE ±.020 ±.020	APPROVED BY: DATE				
	0 PLACE ±.050 ±.050					
	ANGULAR ± 3 °	DRAFT WHERE APPLICABLE MUST REMAIN WITHIN DIMENSIONS	MATERIAL NO. SEE BOM	DOCUMENT NO. SD-34899-0001	TITLE: 12MM 1X2, 1X3 BLADE SEALED ASSEMBLY CABLE SEAL molex	
			SIZE: D		SHEET NO. 1 OF 11	
			THIS DRAWING CONTAINS INFORMATION THAT IS PROPRIETARY TO MOLEX INCORPORATED AND SHOULD NOT BE USED WITHOUT WRITTEN PERMISSION			

1x2 BLADE SEALED ASSEMBLY KEYING CONFIGURATIONS. FOR PART NUMBERS REFER TO BOM SHEET.

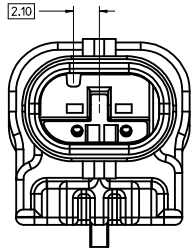

KEYING OPTION A

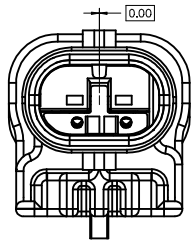

KEYING OPTION B

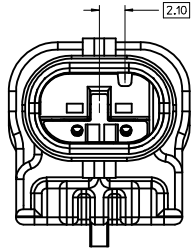

KEYING OPTION C

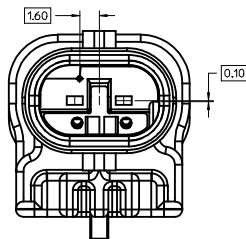

KEYING OPTION E

1x3 VIEWS ADDED EC NO: UAU2016-1535 DRAWN: WANSIAMBROU 2016/04/15 CHKD: APPR: VKOSHY 2016/04/15 REV:	QUALITY SYMBOLS	GENERAL TOLERANCES (UNLESS SPECIFIED)	DIMENSION STYLE	SCALE	DESIGN UNITS	THIRD ANGLE PROJECTION
	▽=0	4 PLACES ± mm ± INCH	MM ONLY	5:1	METRIC	☉
	▽=0	3 PLACES ± 0.10 ± ---				
	▽=0	2 PLACES ± 0.20 ± ---				
		0 PLACE ± 0.50 ±				
		ANGULAR ± 3 °				
		DRAFT WHERE APPLICABLE MUST REMAIN WITHIN DIMENSIONS				
			MATERIAL NO.		DOCUMENT NO.	SHEET NO.
			SEE BOM		SD-34899-2001	2 OF 11
			THIS DRAWING CONTAINS INFORMATION THAT IS PROPRIETARY TO MOLEX INCORPORATED AND SHOULD NOT BE USED WITHOUT WRITTEN PERMISSION			

1x3 BLADE SEALED ASSEMBLY KEYING CONFIGURATIONS. FOR PART NUMBERS REFER TO BOM SHEET.

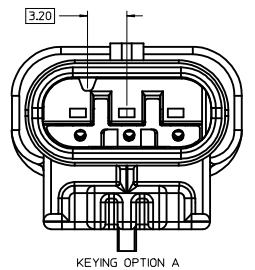

KEYING OPTION A

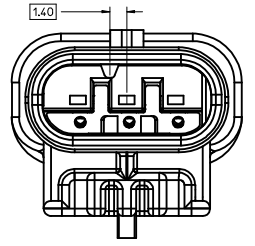

KEYING OPTION B

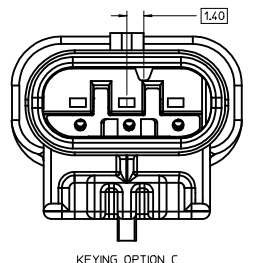

KEYING OPTION C

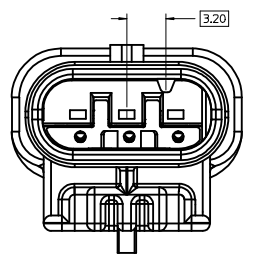

KEYING OPTION D

1x3 VIEWS ADDED DEC NO: JAU2016-1535 DRAWN: WANSIAMBROU 2016/04/15 CHKD: APPR: VKOSHY 2016/04/15 REVISIONS:	QUALITY SYMBOLS	GENERAL TOLERANCES (UNLESS SPECIFIED)	DIMENSION STYLE	SCALE	DESIGN UNITS	THIRD ANGLE PROJECTION
	▽=0 ▽=0 ▽=0	mm INCH 4 PLACES ± --- ± --- 3 PLACES ± --- ± --- 2 PLACES ± 0.10 ± --- 1 PLACE ± 0.20 ± --- 0 PLACE ± 0.50 ±	MM ONLY DRAWN BY SKRA JENDRANA 2013/11/06 CHECKED BY DATE APPROVED BY DATE	5:1 METRIC	TITLE 12MM 1X2, 1X3 BLADE SEALED ASSEMBLY CABLE SEAL molex MATERIAL NO. SEE BOM DOCUMENT NO. SD-34899-2001 SHEET NO. 3 OF 11	
DRAFT WHERE APPLICABLE MUST REMAIN WITHIN DIMENSIONS		THIS DRAWING CONTAINS INFORMATION THAT IS PROPRIETARY TO MOLEX INCORPORATED AND SHOULD NOT BE USED WITHOUT WRITTEN PERMISSION				

CLIP-SLOT CONFIGURATIONS. FOR PART NUMBERS REFER TO BOM SHEET.

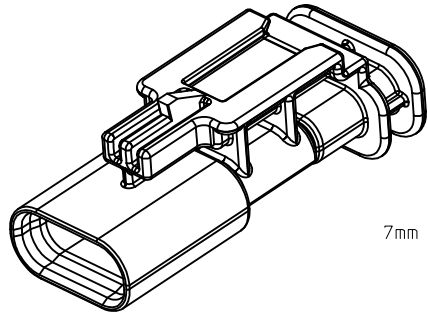

7mm CLIP-SLOT OPTION

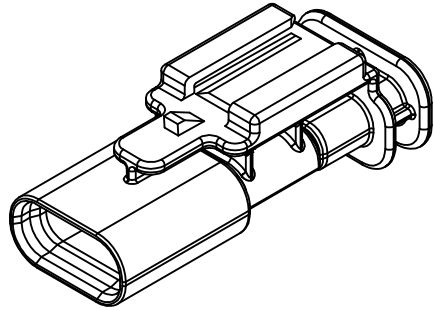
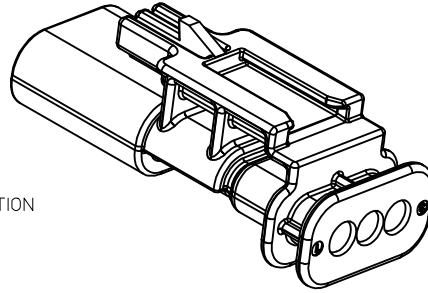

11mm CLIP-SLOT OPTION

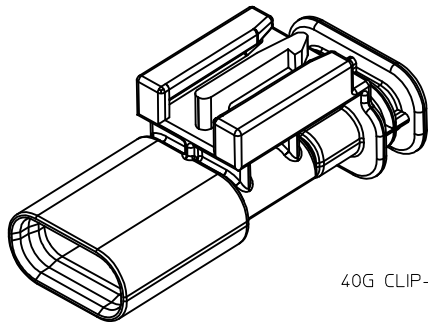
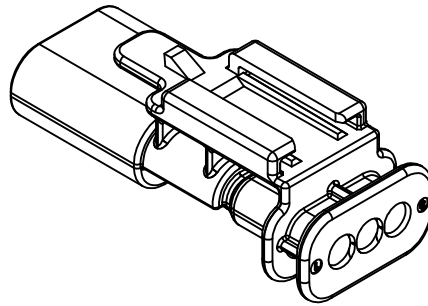

40G CLIP-SLOT OPTION

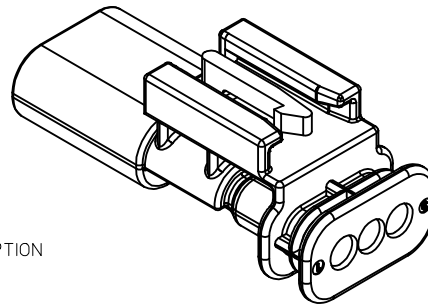

ENTER DESCRIPTION ELEC NO: UAU2016-1535 DRAWN/ANSI: AMBROU/2016/04/15 CHKD: APPR: VKOSHY 2016/04/15 REV:	QUALITY SYMBOLS	GENERAL TOLERANCES (UNLESS SPECIFIED)	DIMENSION STYLE	SCALE	DESIGN UNITS	THIRD ANGLE PROJECTION
	▽=0	mm INCH	MM ONLY	4:1	METRIC	☉
	▽=0	4 PLACES ± --- ± ---	DRAWN BY	DATE	TITLE	
	▽=0	3 PLACES ± --- ± ---	SKRA JENDRANA 2013/11/06	DATE	12MM 1X2, 1X3 BLADE SEALED ASSEMBLY CABLE SEAL	
	2 PLACES ± 0.10 ± ---	1 PLACE ± 0.20 ± ---	0 PLACE ± 0.50 ±	APPROVED BY	DATE	
	ANGULAR ± 3 °		MATERIAL NO.	SEE BOM	DOCUMENT NO.	SHEET NO.
	DRAFT WHERE APPLICABLE MUST REMAIN WITHIN DIMENSIONS		SIZE	D	SD-34899-2001	4 OF 11
	THIS DRAWING CONTAINS INFORMATION THAT IS PROPRIETARY TO MOLEX INCORPORATED AND SHOULD NOT BE USED WITHOUT WRITTEN PERMISSION					

BLADE SEALED ASSEMBLY

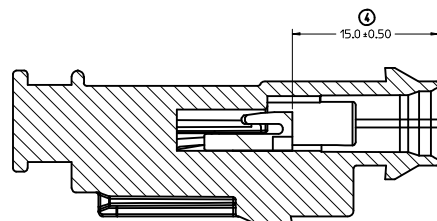
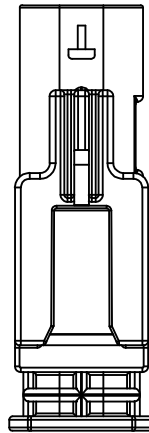
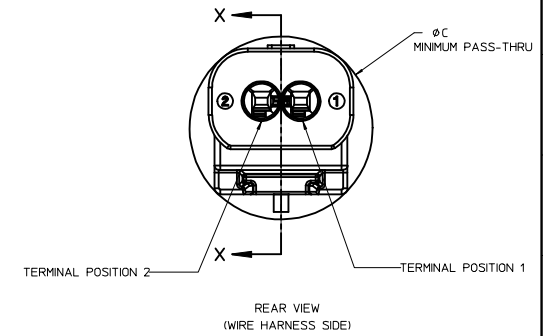
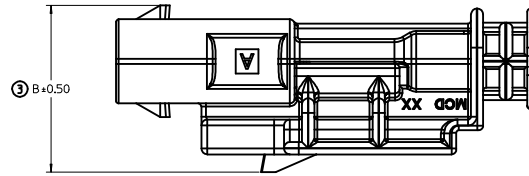
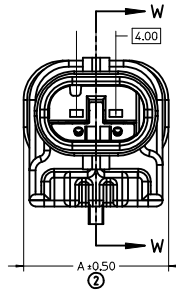
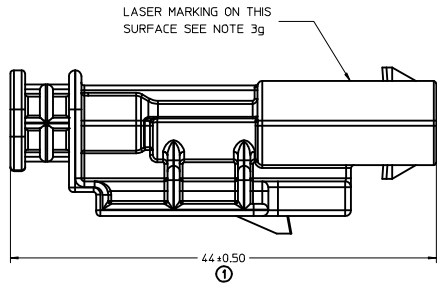

PRIMARY LOCK REINFORCEMENT (PLR) SHOWN
IN THE PRE-STAGED POSITION

SECTION W-W

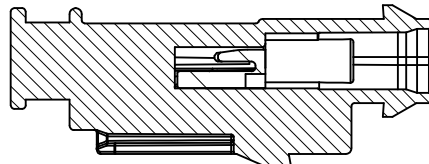

PRIMARY LOCK REINFORCEMENT (PLR) SHOWN
IN THE FINAL-LOCK POSITION

SECTION X-X

1x3 BLADE SEALED ASSEMBLY, 40G CLIP SLOT	19	16.75	21.75
1x3 BLADE SEALED ASSEMBLY, 11mm CLIP SLOT	19	14.6	20.75
1x3 BLADE SEALED ASSEMBLY, 7mm CLIP SLOT	19	17	20.5
1x2 BLADE SEALED ASSEMBLY, 40G CLIP SLOT	15	16.75	20.25
1x2 BLADE SEALED ASSEMBLY, 11mm CLIP SLOT	15	15.5	19
1x2 BLADE SEALED ASSEMBLY, 7mm CLIP SLOT	15	17	18.75
CONFIGURATION	A	B	C

CHARTED DIMENSIONS

1x3 VIEWS ADDED EC NO. UAI/2016-1535 DRAWING/ANSLAMBROU/2016/04/15 CHKD: APPR:VKOSHY REV:	QUALITY SYMBOLS ∇=0 ∇=0 ∇=0	GENERAL TOLERANCES (UNLESS SPECIFIED) mm INCH 4 PLACES ± --- ± --- 3 PLACES ± --- ± --- 2 PLACES ± 0.10 ± --- 1 PLACE ± 0.20 ± --- 0 PLACE ± 0.50 ±	DIMENSION STYLE MM ONLY SCALE 4:1 DESIGN UNITS METRIC THIRD ANGLE PROJECTION	DRAWN BY SKRAJENDRANA DATE 2013/11/06 CHECKED BY DATE	TITLE 12MM 1X2, 1X3 BLADE SEALED ASSEMBLY CABLE SEAL molex
	MATERIAL NO. SEE BOM DOCUMENT NO. SD-34899-2001 SHEET NO. 5 OF 11	DRAFT WHERE APPLICABLE MUST REMAIN WITHIN DIMENSIONS		THIS DRAWING CONTAINS INFORMATION THAT IS PROPRIETARY TO MOLEX INCORPORATED AND SHOULD NOT BE USED WITHOUT WRITTEN PERMISSION	

CONNECTION SYSTEM PACKAGING

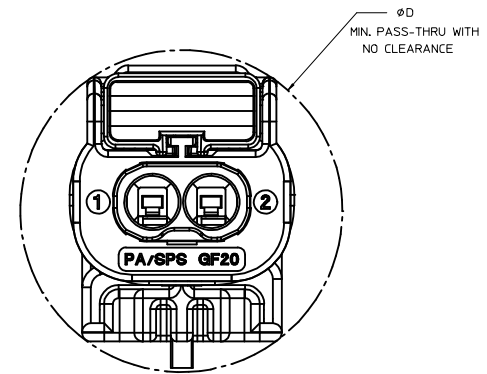
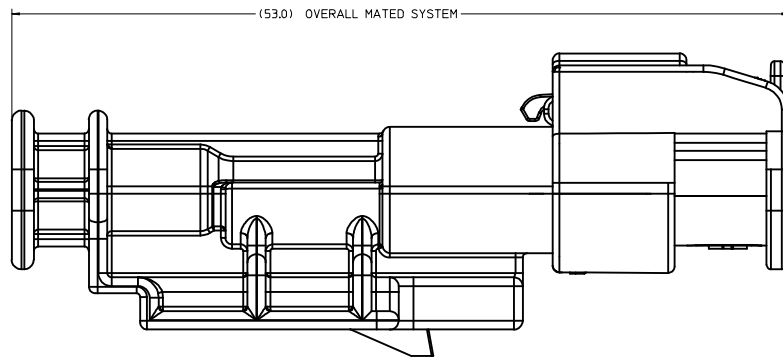

1x3 RECEPTACLE MATED TO 1x3 BLADE, 40 CLIP SLOT	TBD
1x3 RECEPTACLE MATED TO 1x3 BLADE, 11mm CLIP SLOT	24.0
1x3 RECEPTACLE MATED TO 1x3 BLADE, 7mm CLIP SLOT	23.0
1x2 RECEPTACLE MATED TO 1x2 BLADE, 40G CLIP SLOT	23.0
1x2 RECEPTACLE MATED TO 1x2 BLADE, 11mm CLIP SLOT	23.0
1x2 RECEPTACLE MATED TO 1x2 BLADE, 7mm CLIP SLOT	23.0
1.2mm CONNECTION SYSTEM CONFIGURATION	D

CHARTED DIMENSIONS

ENTER DESCRIPTION ELEC NO: UAU2016-1535 DRAWN/ANSI/AMBR01/2016/04/15 CHKD: APPR:VKOSHY 2016/04/15 REV:	QUALITY SYMBOLS	GENERAL TOLERANCES (UNLESS SPECIFIED)	DIMENSION STYLE	SCALE	DESIGN UNITS	THIRD ANGLE PROJECTION
	▽=0	mm INCH	MM ONLY	6:1	METRIC	☉
	▽=0	4 PLACES ± --- ± --- 3 PLACES ± --- ± --- 2 PLACES ± 0.10 ± --- 1 PLACE ± 0.20 ± --- 0 PLACE ± 0.50 ±	DRAWN BY DATE SKRA JENDRANA 2013/11/06	CHECKED BY DATE	TITLE 12MM 1X2, 1X3 BLADE SEALED ASSEMBLY CABLE SEAL	
	▽=0	ANGULAR ± 3 ° DRAFT WHERE APPLICABLE MUST REMAIN WITHIN DIMENSIONS	APPROVED BY DATE	MATERIAL NO. SEE BOM	DOCUMENT NO. SD-34899-2001	SHEET NO. 6 OF 11
A14	SIZE D	THIS DRAWING CONTAINS INFORMATION THAT IS PROPRIETARY TO MOLEX INCORPORATED AND SHOULD NOT BE USED WITHOUT WRITTEN PERMISSION				

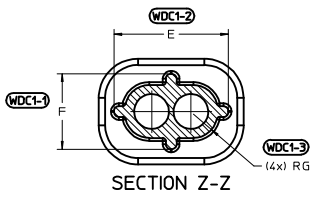

3 CIRCUIT	18.8	10.8	5.4	15.7	7.7	2.45
2 CIRCUIT	14.8	10.8	5.4	11.7	7.7	2.45
CONFIGURATION	A	B	C	E	F	G

CHARTED DIMENSIONS

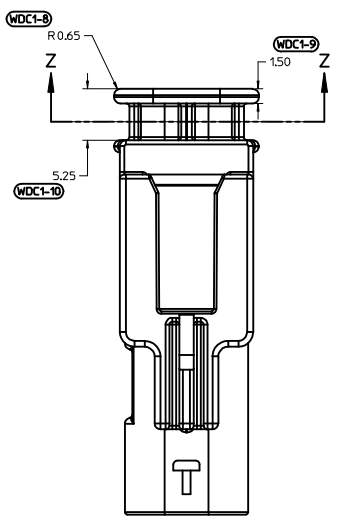
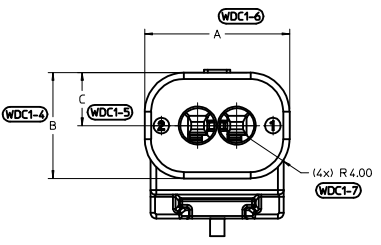

WIRE DRESS COVER
INTERFACE OPTION 1
WIRE DRESS COVERS
NOT AVAILABLE

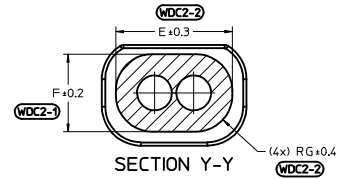

3 CIRCUIT	18.8	10.8	5.4	15.9	7.9	3.7
2 CIRCUIT	14.8	10.3	5.4	11.9	7.9	3.7
CONFIGURATION	A	B	C	E	F	G

CHARTED DIMENSIONS

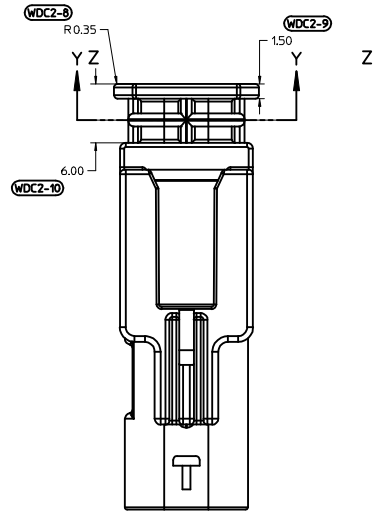
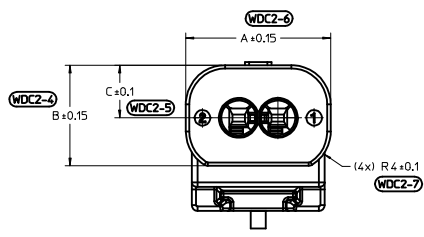

WIRE DRESS COVER
INTERFACE OPTION 2
BASED ON HIRSCHMANN INTERFACE
DRAWING 808-012-xxx REV B5

ENTER DESCRIPTION IEC NO. UAU2016-1535 DRAWING NO. AMBROU 2016/04/15 CHKD: APPR: VOSHY 2016/04/15 REV: A14	QUALITY SYMBOLS	GENERAL TOLERANCES (UNLESS SPECIFIED)	DIMENSION STYLE	SCALE	DESIGN UNITS	THIRD ANGLE PROJECTION
	$\nabla=0$ $\nabla=0$ $\nabla=0$	mm INCH 4 PLACES ± --- ± --- 3 PLACES ± --- ± --- 2 PLACES ± 0.10 ± --- 1 PLACE ± 0.20 ± --- 0 PLACE ± 0.50 ± ---	MM ONLY	4:1	METRIC	
	ANGULAR ± 3 ° DRAFT WHERE APPLICABLE MUST REMAIN WITHIN DIMENSIONS	DRAWN BY: SKRA JENDRANA 2013/11/06 CHECKED BY: DATE APPROVED BY: DATE	MATERIAL NO. SEE TABLE	TITLE 12MM 1X2, 1X3 BLADE SEALED ASSEMBLY CABLE SEAL	DOCUMENT NO. SD-34899-2001	SHEET NO. 7 OF 11
	THIS DRAWING CONTAINS INFORMATION THAT IS PROPRIETARY TO MOLEX INCORPORATED AND SHOULD NOT BE USED WITHOUT WRITTEN PERMISSION					

1x2 BLADE SEALED ASSEMBLY BOM
FOR WIRE DRESS COVER INTERFACE 1
REFER WIRE DRESS COVER INTERFACE SHEET
FOR DETAILS

KEYING OPTION	DESCRIPTION	QTY	A	B	C	E	PLR	PRODUCTION TOOL STATUS	COMMENTS
KEYING OPTION E, 11mm CLIP SLOT, STONE GRAY	34899-2043	1					E	CONCEPT	
KEYING OPTION C, 11mm CLIP SLOT, DARK GRAY	34899-2042	1					C	CONCEPT	
KEYING OPTION B, 11mm CLIP SLOT, LIGHT GRAY	34899-2041	1					B	CONCEPT	
KEYING OPTION A, 11mm CLIP SLOT, BLACK	34899-2040	1					A	CONCEPT	
KEYING OPTION E, 11mm CLIP SLOT, YELLOW	34899-2033	1					E	CONCEPT	
KEYING OPTION C, 11mm CLIP SLOT, YELLOW	34899-2032	1					C	CONCEPT	
KEYING OPTION B, 11mm CLIP SLOT, YELLOW	34899-2031	1					B	CONCEPT	
KEYING OPTION A, 11mm CLIP SLOT, YELLOW	34899-2030	1					A	CONCEPT	
KEYING OPTION E, 7mm CLIP SLOT, STONE GRAY	34899-2023	1					E	TOOLED BUT NOT VALIDATED	
KEYING OPTION C, 7mm CLIP SLOT, DARK GRAY	34899-2022	1					C	TOOLED BUT NOT VALIDATED	
KEYING OPTION B, 7mm CLIP SLOT, LIGHT GRAY	34899-2021	1					B	SALEABLE	
KEYING OPTION A, 7mm CLIP SLOT, BLACK	34899-2020	1					A	SALEABLE	
KEYING OPTION E, 7mm CLIP SLOT, YELLOW	34899-2013	1					E	TOOLED BUT NOT VALIDATED	
KEYING OPTION C, 7mm CLIP SLOT, YELLOW	34899-2012	1					C	TOOLED BUT NOT VALIDATED	
KEYING OPTION B, 7mm CLIP SLOT, YELLOW	34899-2011	1					B	SALEABLE	
KEYING OPTION A, 7mm CLIP SLOT, YELLOW	34899-2010	1					A	SALEABLE	
ASSEMBLY DESCRIPTION								PRODUCTION TOOL STATUS	COMMENTS

PLR	NATURAL	SPS/NYLON GF20
1x2 CONNECTOR HOUSING, KEYING OPTION E 11mm CLIP SLOT	STONE GRAY	SPS/NYLON GF20
1x2 CONNECTOR HOUSING, KEYING OPTION C 11mm CLIP SLOT	DARK GRAY	SPS/NYLON GF20
1x2 CONNECTOR HOUSING, KEYING OPTION B 11mm CLIP SLOT	LIGHT GRAY	SPS/NYLON GF20
1x2 CONNECTOR HOUSING, KEYING OPTION A 11mm CLIP SLOT	BLACK	SPS/NYLON GF20
1x2 CONNECTOR HOUSING, KEYING OPTION E 11mm CLIP SLOT	YELLOW	SPS/NYLON GF20
1x2 CONNECTOR HOUSING, KEYING OPTION C 11mm CLIP SLOT	YELLOW	SPS/NYLON GF20
1x2 CONNECTOR HOUSING, KEYING OPTION B 11mm CLIP SLOT	YELLOW	SPS/NYLON GF20
1x2 CONNECTOR HOUSING, KEYING OPTION A 11mm CLIP SLOT	YELLOW	SPS/NYLON GF20
1x2 CONNECTOR HOUSING, KEYING OPTION E 7mm CLIP SLOT	STONE GRAY	SPS/NYLON GF20
1x2 CONNECTOR HOUSING, KEYING OPTION C 7mm CLIP SLOT	DARK GRAY	SPS/NYLON GF20
1x2 CONNECTOR HOUSING, KEYING OPTION B 7mm CLIP SLOT	LIGHT GRAY	SPS/NYLON GF20
1x2 CONNECTOR HOUSING, KEYING OPTION A 7mm CLIP SLOT	BLACK	SPS/NYLON GF20
1x2 CONNECTOR HOUSING, KEYING OPTION E 7mm CLIP SLOT	YELLOW	SPS/NYLON GF20
1x2 CONNECTOR HOUSING, KEYING OPTION C 7mm CLIP SLOT	YELLOW	SPS/NYLON GF20
1x2 CONNECTOR HOUSING, KEYING OPTION B 7mm CLIP SLOT	YELLOW	SPS/NYLON GF20
1x2 CONNECTOR HOUSING, KEYING OPTION A 7mm CLIP SLOT	YELLOW	SPS/NYLON GF20

DESCRIPTION	COLOR	MATERIAL
BOM/APPLICABLE COMPONENTS TABLE		

ABBREVIATION	COMPONENT
A	CONNECTOR HOUSING KEYING OPTION A
B	CONNECTOR HOUSING KEYING OPTION B
C	CONNECTOR HOUSING KEYING OPTION C
E	CONNECTOR HOUSING KEYING OPTION E

ENTER DESCRIPTION ELEC NO. UAU2016-1535 DRAWING NO. AMB0012016/04/15 CHKD: APPR: VKOSHY 2016/04/15 REV:	QUALITY SYMBOLS ∇=0 ∇=0 ∇=0	GENERAL TOLERANCES (UNLESS SPECIFIED) mm INCH 4 PLACES ± --- ± --- 3 PLACES ± --- ± --- 2 PLACES ± 0.10 ± --- 1 PLACE ± 0.20 ± --- 0 PLACE ± 0.50 ±	DIMENSION STYLE MM ONLY	SCALE 2:1	DESIGN UNITS METRIC	THIRD ANGLE PROJECTION 	TITLE 12MM 1X2, 1X3 BLADE SEALED ASSEMBLY CABLE SEAL
	MATERIAL NO. SEE BOM	DOCUMENT NO. SD-34899-2001	SHEET NO. 8 OF 11				

THIS DRAWING CONTAINS INFORMATION THAT IS PROPRIETARY TO MOLEX INCORPORATED AND SHOULD NOT BE USED WITHOUT WRITTEN PERMISSION

1x2 BLADE SEALED ASSEMBLY BOM
 FOR WIRE DRESS COVER INTERFACE 2
 REFER WIRE DRESS COVER INTERFACE SHEET
 FOR DETAILS

KEYING OPTION A, 40G CLIP SLOT, BLACK	34899-2060	2															A			OK TO TOOL	
KEYING OPTION A, 40G CLIP SLOT, YELLOW	34899-2050	2															A			OK TO TOOL	
KEYING OPTION E, 7mm CLIP SLOT, STONE GRAY	34899-2083	2															E			OK TO TOOL	
KEYING OPTION C, 7mm CLIP SLOT, DARK GRAY	34899-2082	2															C			OK TO TOOL	
KEYING OPTION B, 7mm CLIP SLOT, LIGHT GRAY	34899-2081	2															B			SALEABLE	
KEYING OPTION A, 7mm CLIP SLOT, BLACK	34899-2080	2															A			SALEABLE	
KEYING OPTION E, 7mm CLIP SLOT, YELLOW	34899-2073	2															E			OK TO TOOL	
KEYING OPTION C, 7mm CLIP SLOT, YELLOW	34899-2072	2															C			OK TO TOOL	
KEYING OPTION B, 7mm CLIP SLOT, YELLOW	34899-2071	2															B			SALEABLE	
KEYING OPTION A, 7mm CLIP SLOT, YELLOW	34899-2070	2															A			SALEABLE	
ASSEMBLY DESCRIPTION	ASSEMBLY PART NUMBER	WIRE DRESS COVER INTERFACE OPTION											PRODUCTION TOOL STATUS	COMMENTS							

PLR	NATURAL	SPS/NYLON GF20
1x2 CONNECTOR HOUSING, KEYING OPTION A 40G CLIP SLOT	BLACK	SPS/NYLON GF20
1x2 CONNECTOR HOUSING, KEYING OPTION A 40G CLIP SLOT	YELLOW	SPS/NYLON GF20
1x2 CONNECTOR HOUSING, KEYING OPTION E 7mm CLIP SLOT	STONE GRAY	SPS/NYLON GF20
1x2 CONNECTOR HOUSING, KEYING OPTION C 7mm CLIP SLOT	DARK GRAY	SPS/NYLON GF20
1x2 CONNECTOR HOUSING, KEYING OPTION B 7mm CLIP SLOT	LIGHT GRAY	SPS/NYLON GF20
1x2 CONNECTOR HOUSING, KEYING OPTION A 7mm CLIP SLOT	BLACK	SPS/NYLON GF20
1x2 CONNECTOR HOUSING, KEYING OPTION E 7mm CLIP SLOT	YELLOW	SPS/NYLON GF20
1x2 CONNECTOR HOUSING, KEYING OPTION C 7mm CLIP SLOT	YELLOW	SPS/NYLON GF20
1x2 CONNECTOR HOUSING, KEYING OPTION B 7mm CLIP SLOT	YELLOW	SPS/NYLON GF20
1x2 CONNECTOR HOUSING, KEYING OPTION A 7mm CLIP SLOT	YELLOW	SPS/NYLON GF20

DESCRIPTION	COLOR	MATERIAL
BOM/APPLICABLE COMPONENTS TABLE		

LEGEND TABLE	
ABBREVIATION	COMPONENT
A	CONNECTOR HOUSING KEYING OPTION A
B	CONNECTOR HOUSING KEYING OPTION B
C	CONNECTOR HOUSING KEYING OPTION C
E	CONNECTOR HOUSING KEYING OPTION E

ENTER DESCRIPTION ELEC NO: UAU2016-1535 DRAWING/ANSI/MBROU/2016/04/15 CHKD: APPR:VKOSHY 2016/04/15 REV:	QUALITY SYMBOLS $\nabla=0$ $\nabla=0$ $\nabla=0$	GENERAL TOLERANCES (UNLESS SPECIFIED)		DIMENSION STYLE MM ONLY	SCALE DESIGN UNITS METRIC	THIRD ANGLE PROJECTION
		4 PLACES \pm mm \pm INCH 3 PLACES \pm --- \pm --- 2 PLACES ± 0.10 \pm --- 1 PLACE ± 0.20 \pm --- 0 PLACE ± 0.50 \pm	SKRA JENDRANA 2013/11/06 CHECKED BY DATE	APPROVED BY DATE	MATERIAL NO. SEE BOM	DOCUMENT NO. SD-34899-2001
DRAFT WHERE APPLICABLE MUST REMAIN WITHIN DIMENSIONS		ANGULAR $\pm 3^\circ$		12MM 1X2, 1X3 BLADE SEALED ASSEMBLY CABLE SEAL 		
THIS DRAWING CONTAINS INFORMATION THAT IS PROPRIETARY TO MOLEX INCORPORATED AND SHOULD NOT BE USED WITHOUT WRITTEN PERMISSION						

1x3 BLADE SEALED ASSEMBLY BOM
 FOR WIRE DRESS COVER INTERFACE 1
 REFER WIRE DRESS COVER INTERFACE SHEET
 FOR DETAILS

ASSEMBLY DESCRIPTION	ASSEMBLY PART NUMBER	WIRE DRESS COVER INTERFACE OPTION													PRODUCTION TOOL STATUS	COMMENTS	MODEL NUMBER		
KEYING OPTION D, 11mm CLIP SLOT, STONE GRAY	34899-3043	1														D	TOOLED BUT NOT VALIDATED		EM-34899-3033
KEYING OPTION C, 11mm CLIP SLOT, DARK GRAY	34899-3042	1														C	TOOLED BUT NOT VALIDATED		EM-34899-3032
KEYING OPTION B, 11mm CLIP SLOT, LIGHT GRAY	34899-3041	1														B	SALEABLE		EM-34899-3031
KEYING OPTION A, 11mm CLIP SLOT, BLACK	34899-3040	1														A	SALEABLE		EM-34899-3030
KEYING OPTION D, 11mm CLIP SLOT, YELLOW	34899-3033	1														D	TOOLED BUT NOT VALIDATED		EM-34899-3033
KEYING OPTION C, 11mm CLIP SLOT, YELLOW	34899-3032	1														C	TOOLED BUT NOT VALIDATED		EM-34899-3032
KEYING OPTION B, 11mm CLIP SLOT, YELLOW	34899-3031	1														B	SALEABLE		EM-34899-3031
KEYING OPTION A, 11mm CLIP SLOT, YELLOW	34899-3030	1														A	SALEABLE		EM-34899-3030
KEYING OPTION D, 7mm CLIP SLOT, STONE GRAY	34899-3023	1														D	TOOLED BUT NOT VALIDATED		EM-34899-3013
KEYING OPTION C, 7mm CLIP SLOT, DARK GRAY	34899-3022	1														C	TOOLED BUT NOT VALIDATED		EM-34899-3012
KEYING OPTION B, 7mm CLIP SLOT, LIGHT GRAY	34899-3021	1														B	SALEABLE		EM-34899-3011
KEYING OPTION A, 7mm CLIP SLOT, BLACK	34899-3020	1														A	SALEABLE		EM-34899-3010
KEYING OPTION D, 7mm CLIP SLOT, YELLOW	34899-3013	1														D	TOOLED BUT NOT VALIDATED		EM-34899-3013
KEYING OPTION C, 7mm CLIP SLOT, YELLOW	34899-3012	1														C	TOOLED BUT NOT VALIDATED		EM-34899-3012
KEYING OPTION B, 7mm CLIP SLOT, YELLOW	34899-3011	1														B	SALEABLE		EM-34899-3011
KEYING OPTION A, 7mm CLIP SLOT, YELLOW	34899-3010	1														A	SALEABLE		EM-34899-3010

DESCRIPTION	COLOR	MATERIAL
PLR		
1x3 CONNECTOR HOUSING, KEYING OPTION D 11mm CLIP SLOT	STONE GRAY	SPS/NYLON GF20
1x3 CONNECTOR HOUSING, KEYING OPTION C 11mm CLIP SLOT	DARK GRAY	SPS/NYLON GF20
1x3 CONNECTOR HOUSING, KEYING OPTION B 11mm CLIP SLOT	LIGHT GRAY	SPS/NYLON GF20
1x3 CONNECTOR HOUSING, KEYING OPTION A 11mm CLIP SLOT	BLACK	SPS/NYLON GF20
1x3 CONNECTOR HOUSING, KEYING OPTION D 11mm CLIP SLOT	YELLOW	SPS/NYLON GF20
1x3 CONNECTOR HOUSING, KEYING OPTION C 11mm CLIP SLOT	YELLOW	SPS/NYLON GF20
1x3 CONNECTOR HOUSING, KEYING OPTION B 11mm CLIP SLOT	YELLOW	SPS/NYLON GF20
1x3 CONNECTOR HOUSING, KEYING OPTION A 11mm CLIP SLOT	YELLOW	SPS/NYLON GF20
1x3 CONNECTOR HOUSING, KEYING OPTION D 7mm CLIP SLOT	STONE GRAY	SPS/NYLON GF20
1x3 CONNECTOR HOUSING, KEYING OPTION C 7mm CLIP SLOT	DARK GRAY	SPS/NYLON GF20
1x3 CONNECTOR HOUSING, KEYING OPTION B 7mm CLIP SLOT	LIGHT GRAY	SPS/NYLON GF20
1x3 CONNECTOR HOUSING, KEYING OPTION A 7mm CLIP SLOT	BLACK	SPS/NYLON GF20
1x3 CONNECTOR HOUSING, KEYING OPTION D 7mm CLIP SLOT	YELLOW	SPS/NYLON GF20
1x3 CONNECTOR HOUSING, KEYING OPTION C 7mm CLIP SLOT	YELLOW	SPS/NYLON GF20
1x3 CONNECTOR HOUSING, KEYING OPTION B 7mm CLIP SLOT	YELLOW	SPS/NYLON GF20
1x3 CONNECTOR HOUSING, KEYING OPTION A 7mm CLIP SLOT	YELLOW	SPS/NYLON GF20

BOM/APPLICABLE COMPONENTS TABLE

LEGEND TABLE	
ABBREVIATION	COMPONENT
A	CONNECTOR HOUSING KEYING OPTION A
B	CONNECTOR HOUSING KEYING OPTION B
C	CONNECTOR HOUSING KEYING OPTION C
D	CONNECTOR HOUSING KEYING OPTION D

ENTER DESCRIPTION IEC NO. JAU2016-1535 DRAWING NO. AMBRO2016/04/15 CHKD: APPR: VKSHY 2016/04/15 REV: A14	QUALITY SYMBOLS ▽=0 ▽=0 ▽=0	GENERAL TOLERANCES (UNLESS SPECIFIED) mm INCH 4 PLACES ± --- ± --- 3 PLACES ± --- ± --- 2 PLACES ± 0.10 ± --- 1 PLACE ± 0.20 ± --- 0 PLACE ± 0.50 ±	DIMENSION STYLE MM ONLY	SCALE DESIGN UNITS METRIC	THIRD ANGLE PROJECTION
	DRAWN BY SKRA JENDRANA 2013/11/06 CHECKED BY DATE APPROVED BY DATE		TITLE 12MM 1X2, 1X3 BLADE SEALED ASSEMBLY CABLE SEAL		molex DOCUMENT NO. SD-34899-2001 SHEET NO. 10 OF 11
	DRAFT WHERE APPLICABLE MUST REMAIN WITHIN DIMENSIONS SIZE D		MATERIAL NO. SEE BOM THIS DRAWING CONTAINS INFORMATION THAT IS PROPRIETARY TO MOLEX INCORPORATED AND SHOULD NOT BE USED WITHOUT WRITTEN PERMISSION		

1x3 BLADE SEALED ASSEMBLY BOM
 FOR WIRE DRESS COVER INTERFACE 2
 REFER WIRE DRESS COVER INTERFACE SHEET
 FOR DETAILS

KEYING OPTION A, 40-G CLIP SLOT, BLACK	34899-3060	2																	A	CONCEPT	EM-34899-3050
KEYING OPTION A, 40-G CLIP SLOT, YELLOW	34899-3050	2																	A	CONCEPT	EM-34899-3050
KEYING OPTION D, 11mm CLIP SLOT, STONE GRAY	34899-3123	2																	D	OK TO TOOL	EM-34899-3033
KEYING OPTION C, 11mm CLIP SLOT, DARK GRAY	34899-3122	2																	C	OK TO TOOL	EM-34899-3032
KEYING OPTION B, 11mm CLIP SLOT, LIGHT GRAY	34899-3121	2																	B	SALEABLE	EM-34899-3031
KEYING OPTION A, 11mm CLIP SLOT, BLACK	34899-3120	2																	A	SALEABLE	EM-34899-3030
KEYING OPTION D, 11mm CLIP SLOT, YELLOW	34899-3113	2																	D	OK TO TOOL	EM-34899-3033
KEYING OPTION C, 11mm CLIP SLOT, YELLOW	34899-3112	2																	C	OK TO TOOL	EM-34899-3032
KEYING OPTION B, 11mm CLIP SLOT, YELLOW	34899-3111	2																	B	SALEABLE	EM-34899-3031
KEYING OPTION A, 11mm CLIP SLOT, YELLOW	34899-3110	2																	A	SALEABLE	EM-34899-3030
KEYING OPTION D, 7mm CLIP SLOT, STONE GRAY	34899-3093	2																	D	OK TO TOOL	EM-34899-3013
KEYING OPTION C, 7mm CLIP SLOT, DARK GRAY	34899-3092	2																	C	OK TO TOOL	EM-34899-3012
KEYING OPTION B, 7mm CLIP SLOT, LIGHT GRAY	34899-3091	2																	B	SALEABLE	EM-34899-3011
KEYING OPTION A, 7mm CLIP SLOT, BLACK	34899-3090	2																	A	SALEABLE	EM-34899-3010
KEYING OPTION D, 7mm CLIP SLOT, YELLOW	34899-3083	2																	D	OK TO TOOL	EM-34899-3013
KEYING OPTION C, 7mm CLIP SLOT, YELLOW	34899-3082	2																	C	OK TO TOOL	EM-34899-3012
KEYING OPTION B, 7mm CLIP SLOT, YELLOW	34899-3081	2																	B	SALEABLE	EM-34899-3011
KEYING OPTION A, 7mm CLIP SLOT, YELLOW	34899-3080	2																	A	SALEABLE	EM-34899-3010

ASSEMBLY DESCRIPTION	ASSEMBLY PART NUMBER	WIRE DRESS COVER INTERFACE OPTION	PRODUCTION TOOL STATUS	COMMENTS	MODEL NUMBER
ASSEMBLY DESCRIPTION	ASSEMBLY PART NUMBER	WIRE DRESS COVER INTERFACE OPTION			

PLR	NATURAL	SPS/NYLON GF20
1x3 CONNECTOR HOUSING, KEYING OPTION A 40G CLIP SLOT	BLACK	SPS/NYLON GF20
1x3 CONNECTOR HOUSING, KEYING OPTION A 40GCLIP SLOT	YELLOW	SPS/NYLON GF20
1x3 CONNECTOR HOUSING, KEYING OPTION D 11mm CLIP SLOT	STONE GRAY	SPS/NYLON GF20
1x3 CONNECTOR HOUSING, KEYING OPTION C 11mm CLIP SLOT	DARK GRAY	SPS/NYLON GF20
1x3 CONNECTOR HOUSING, KEYING OPTION B 11mm CLIP SLOT	LIGHT GRAY	SPS/NYLON GF20
1x3 CONNECTOR HOUSING, KEYING OPTION A 11mm CLIP SLOT	BLACK	SPS/NYLON GF20
1x3 CONNECTOR HOUSING, KEYING OPTION D 11mm CLIP SLOT	YELLOW	SPS/NYLON GF20
1x3 CONNECTOR HOUSING, KEYING OPTION C 11mm CLIP SLOT	YELLOW	SPS/NYLON GF20
1x3 CONNECTOR HOUSING, KEYING OPTION B 11mm CLIP SLOT	YELLOW	SPS/NYLON GF20
1x3 CONNECTOR HOUSING, KEYING OPTION A 11mm CLIP SLOT	YELLOW	SPS/NYLON GF20
1x3 CONNECTOR HOUSING, KEYING OPTION D 7mm CLIP SLOT	STONE GRAY	SPS/NYLON GF20
1x3 CONNECTOR HOUSING, KEYING OPTION C 7mm CLIP SLOT	DARK GRAY	SPS/NYLON GF20
1x3 CONNECTOR HOUSING, KEYING OPTION B 7mm CLIP SLOT	LIGHT GRAY	SPS/NYLON GF20
1x3 CONNECTOR HOUSING, KEYING OPTION A 7mm CLIP SLOT	BLACK	SPS/NYLON GF20
1x3 CONNECTOR HOUSING, KEYING OPTION D 7mm CLIP SLOT	YELLOW	SPS/NYLON GF20
1x3 CONNECTOR HOUSING, KEYING OPTION C 7mm CLIP SLOT	YELLOW	SPS/NYLON GF20
1x3 CONNECTOR HOUSING, KEYING OPTION B 7mm CLIP SLOT	YELLOW	SPS/NYLON GF20
1x3 CONNECTOR HOUSING, KEYING OPTION A 7mm CLIP SLOT	YELLOW	SPS/NYLON GF20

DESCRIPTION COLOR MATERIAL

BOM/APPLICABLE COMPONENTS TABLE

ABBREVIATION	COMPONENT
A	CONNECTOR HOUSING KEYING OPTION A
B	CONNECTOR HOUSING KEYING OPTION B
C	CONNECTOR HOUSING KEYING OPTION C
D	CONNECTOR HOUSING KEYING OPTION D

ENTER DESCRIPTION LEC NO. UAU2016-1535 DRAWN/WAN/AMBRO/2016/04/15 CHKD. APPR: VIOSHTY 2016/04/15 REV A14	QUALITY SYMBOLS ▽=0 ▽=0 ▽=0	GENERAL TOLERANCES (UNLESS SPECIFIED) mm INCH 4 PLACES ± --- ± --- 3 PLACES ± --- ± --- 2 PLACES ± 0.10 ± --- 1 PLACE ± 0.20 ± --- 0 PLACE ± 0.50 ±	DIMENSION STYLE MM ONLY	SCALE DESIGN UNITS METRIC	THIRD ANGLE PROJECTION TITLE 12MM 1X2, 1X3 BLADE SEALED ASSEMBLY CABLE SEAL
	MATERIAL NO. SEE BOM	DOCUMENT NO. SD-34899-2001	SHEET NO. 11 OF 11		

TABLE OF CONTENTS

SHEET NO.	SHEET DESCRIPTION
1	NOTES
2	1x4 BLADE SEALED ASSEMBLY KEYING CONFIGURATIONS
3	1x6 BLADE SEALED ASSEMBLY KEYING CONFIGURATIONS
4	CLIP SLOT CONFIGURATIONS
5	BLADE SEALED ASSEMBLY
6	CONNECTION SYSTEM PACKAGING
7	WIRE DRESS COVER INTERFACE OPTIONS
8	1x4 BLADE SEALED ASSEMBLY BOM INTERFACE OPTION 1
9	1x4 BLADE SEALED ASSEMBLY BOM INTERFACE OPTION 2
10	1x6 BLADE SEALED ASSEMBLY BOM INTERFACE OPTION 1
11	1x6 BLADE SEALED ASSEMBLY BOM INTERFACE OPTION 2

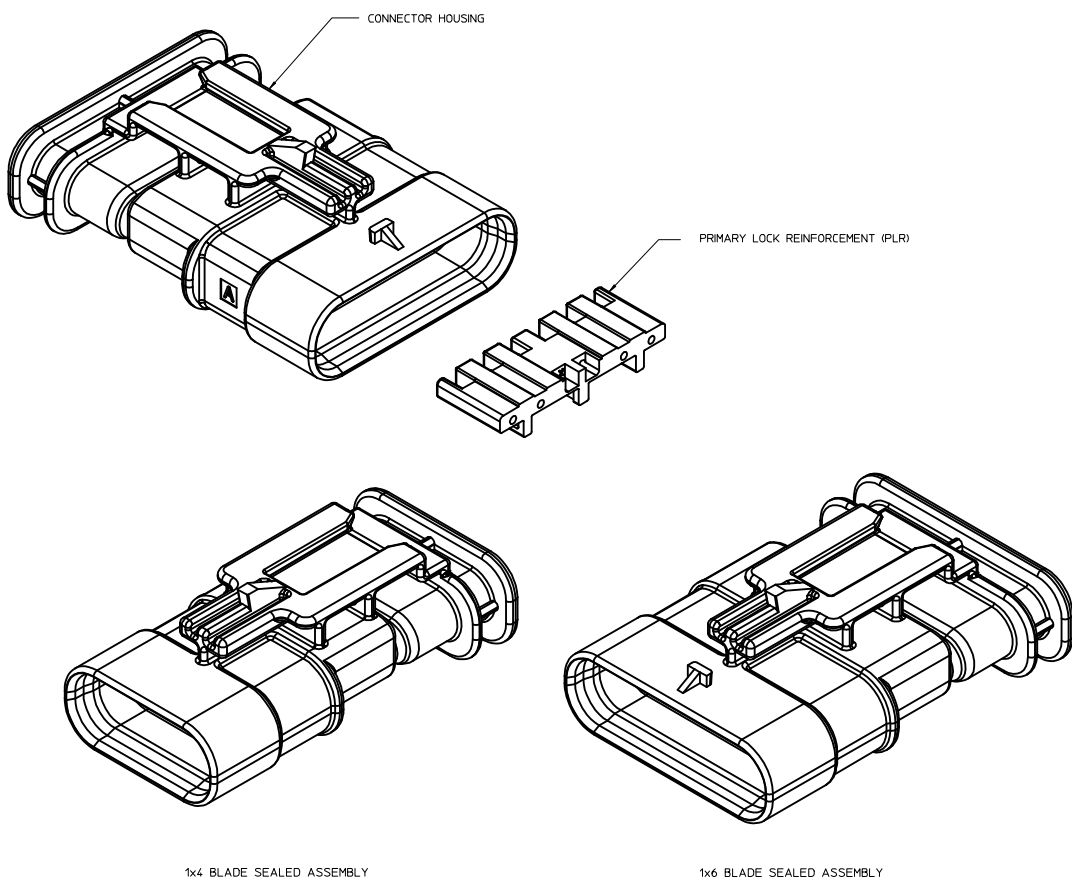

NOTES: VALID UNLESS OTHERWISE SPECIFIED

1. GENERAL:
a. APPLICATION SPECIFICATION SEE: AS-34900-0001
CONTAINS: PRODUCT INTRODUCTION, PRODUCT SUMMARY, CONNECTOR ASSEMBLY, PACKAGING INFORMATION, CONNECTOR MATING, SERVICE INSTRUCTIONS, ELECTRICAL CONTINUITY CHECKING, CRIMPING, AND TROUBLESHOOTING.
b. PRODUCT SPECIFICATION SEE: PS-34900-0001
CONTAINS: PRODUCT INTRODUCTION, PRODUCT SUMMARY, RATINGS (CURRENT, TEMPERATURE, SEALING, AND FLAMMABILITY), AND PRODUCT VALIDATION.
c. PACKAGING SPECIFICATION PER MOLEX DRAWING: PK-31301-898
d. PARTS MUST BE IN COMPLIANCE TO MOLEX CHEMICAL SUBSTANCES FOR PRODUCTS AND PACKAGING SPECIFICATION: QEHS-699000-301
e. DATA MUST BE SUBMITTED UNDER THE MOLEX PART NUMBER TO IMDS (COMPANY ID#13255)

2. DESIGN - MATERIALS:
a. SEE BOM TABLE

3. DESIGN - GEOMETRY:
a. THIS IS A 100% CAD GENERATED PART. THE CAD MATHEMATICAL DATA IS THE MASTER FOR THIS PART. FOR DIMENSIONAL OR ANY INFORMATION NOT SHOWN ON THIS DRAWING, ANALYZE THE CAD MODEL.
b. GEOMETRIC DIMENSIONS AND TOLERANCES PER ASME Y14.5M - 1994
c. EDGES AND UNDIMENSIONED DETAILS PER ISO13715
d. CORNERS SHOWN AS SHARP TO BE R 0.2 MAX.
e. LETTERING SHALL BE 0.15 MAX RAISED IN 0.25 MAX RECESS PAD. THIS INCLUDES RECYCLING CODE, CAVITY ID, VENDOR IDENTIFICATION, AND CUSTOMER MATERIAL NUMBER.
f. VISUAL DEFECTS SHALL MEET COSMETIC STANDARD PS-45499-002 (Class B)

g. LASER MARKING:
1. PART NUMBER
2. DAY OF THE YEAR
3. SHIFT
4. YEAR

INSPECTION BALLOON NUMBER LOG
PER DRAWING REVISION: B12
LAST BALLOON NUMBER USED: WDC2-10
ADDED BALLOON NUMBERS: WDC2-1 - WDC2-10
REMOVED BALLOON NUMBERS:

ENTER DESCRIPTION CAD NO.: UAU2016-1803 DRAWN: KOWALSKI CHKD.: APPR: KOWALSKI DATE: 2016/06/01 DESCRIPTION: 2016/06/15 REV: B15	QUALITY SYMBOLS ∇=0 ∇=0 ∇=0	GENERAL TOLERANCES (UNLESS SPECIFIED): <table border="1"> <thead> <tr> <th></th> <th>mm</th> <th>INCH</th> </tr> </thead> <tbody> <tr> <td>4 PLACES</td> <td>±.00</td> <td>±.00</td> </tr> <tr> <td>3 PLACES</td> <td>±.01</td> <td>±.00</td> </tr> <tr> <td>2 PLACES</td> <td>±.02</td> <td>±.00</td> </tr> <tr> <td>1 PLACE</td> <td>±.05</td> <td>±.00</td> </tr> <tr> <td>0 PLACE</td> <td>±.10</td> <td>±.00</td> </tr> </tbody> </table>		mm	INCH	4 PLACES	±.00	±.00	3 PLACES	±.01	±.00	2 PLACES	±.02	±.00	1 PLACE	±.05	±.00	0 PLACE	±.10	±.00	DIMENSION STYLE MM ONLY DRAWN BY: MYANSLAMBROU DATE: 2012/07/13 CHECKED BY: YKOSHY DATE: 2012/07/19 APPROVED BY: YKOSHY DATE: 2012/07/124	SCALE: 4:1 DESIGN UNITS: METRIC THIRD ANGLE PROJECTION	TITLE: 12MM 1X4, 1X6 BLADE SEALED ASSEMBLY CABLE SEAL molex	MATERIAL NO.: SEE BOM	DOCUMENT NO.: SD-34899-6001	SHEET NO.: 1 OF 11
		mm	INCH																							
	4 PLACES	±.00	±.00																							
	3 PLACES	±.01	±.00																							
2 PLACES	±.02	±.00																								
1 PLACE	±.05	±.00																								
0 PLACE	±.10	±.00																								
DRAFT WHERE APPLICABLE MUST REMAIN WITHIN DIMENSIONS																										
THIS DRAWING CONTAINS INFORMATION THAT IS PROPRIETARY TO MOLEX INCORPORATED AND SHOULD NOT BE USED WITHOUT WRITTEN PERMISSION																										
REMOVED BALLOON NUMBERS:																										

B15	UPDATED BALLOONS 2-1 & 2-2 ON SHEET 7
B14	UPDATED PARTS TO SALEABLE
B13	RELEASED PRIMARY KEYS NON-SIR SALEABLE
B12	UPDATED PLR LOCK UP GEOMETRY
B11	UPDATED WDC INTERFACE PART# TO TOOLED BUT NOT VALIDATED
B10	UPDATED TOLERANCES WDC FEATURES
B9	1X4, 1X6 PART # WIRE DRESS COVER INTERFACE FEATURES OK TO TOOL
B8	1X4 40G CLIP-SLOT OK TO TOOL
B7	1X4 PART # UPDATED TO 'TOOLED BUT NOT VALIDATED'
B6	ADDED 40G CLIP-SLOT PART NUMBERS
B5	BOM CORRECTIONS AND UPDATES
B4	BOM CORRECTIONS AND UPDATES
B3	1x4, 1x6 NON-SIR PART# OK TO TOOL
B2	1x6 11mm CLIP SLOT PART # OK TO TOOL
B1	1x6 11mm CLIP SLOT PART NUMBERS ADDED
B	ADDED 1x4 INFORMATION
A	OK TO TOOL
REV	DESCRIPTION

1x4 BLADE SEALED ASSEMBLY KEYING CONFIGURATIONS. FOR PART NUMBERS REFER TO BOM SHEET.

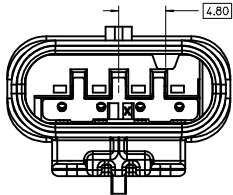

KEYING OPTION A

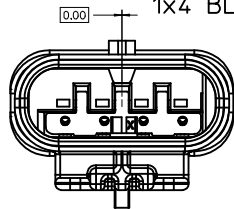

KEYING OPTION F

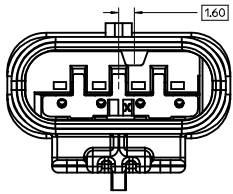

KEYING OPTION B

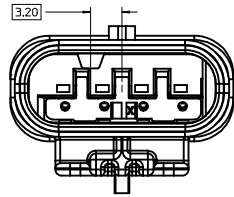

KEYING OPTION G

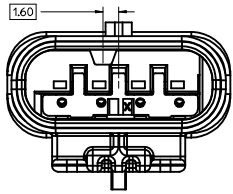

KEYING OPTION C

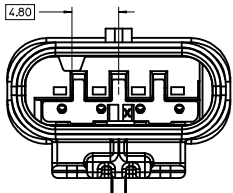

KEYING OPTION D

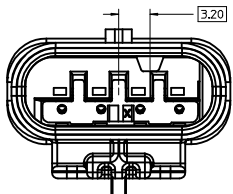

KEYING OPTION E

ENTER DESCRIPTION EC NO: UAU2016-1803 DRAWN: KOWALSKI 2016/06/01 CHKD: CHYD APPR: KOJEKSKI 2016/06/15 REVISIONS B15	QUALITY SYMBOLS	GENERAL TOLERANCES (UNLESS SPECIFIED)	DIMENSION STYLE	SCALE	DESIGN UNITS	THIRD ANGLE PROJECTION	
	∇=0 ∇=0 ∇=0	4 PLACES ± mm ± INCH 3 PLACES ± mm ± INCH 2 PLACES ± 0.10 ± mm ± INCH 1 PLACE ± 0.20 ± mm ± INCH 0 PLACE ± 0.50 ± mm ± INCH	MM ONLY	4:1	METRIC	DRAWN BY: MYANSLAMBROU DATE: 2012/07/13 CHECKED BY: VKOSHY DATE: 2012/07/19 APPROVED BY: VKOSHY DATE: 2012/07/24	TITLE: 12MM 1X4, 1X6 BLADE SEALED ASSEMBLY CABLE SEAL MATERIAL NO: SEE BOM DOCUMENT NO: SD-34899-6001
	ANGULAR ± 3 ° DRAFT WHERE APPLICABLE MUST REMAIN WITHIN DIMENSIONS	SIZE D	SHEET NO. 2 OF 11				
	THIS DRAWING CONTAINS INFORMATION THAT IS PROPRIETARY TO MOLEX INCORPORATED AND SHOULD NOT BE USED WITHOUT WRITTEN PERMISSION						

1x6 BLADE SEALED ASSEMBLY KEYING CONFIGURATIONS. FOR PART NUMBERS REFER TO BOM SHEET.

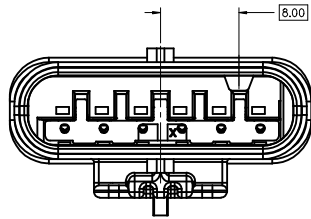

KEYING OPTION A

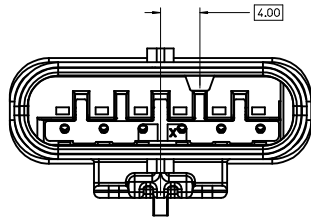

KEYING OPTION B

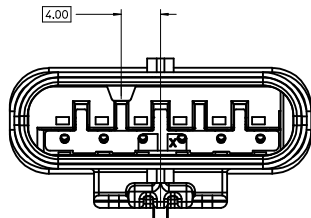

KEYING OPTION C

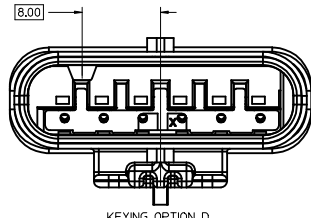

KEYING OPTION D

ENTER DESCRIPTION EC NO: UAU2016-1803 DRAWN: KOKOMALSKY 2016/06/07 CHKD: CHYD APPR: KOKOSKI 2016/06/15 REV: DESCRIPTION	QUALITY SYMBOLS ▽=0 ▽=0 ▽=0		GENERAL TOLERANCES (UNLESS SPECIFIED) <table border="1"> <thead> <tr> <th></th> <th>mm</th> <th>INCH</th> </tr> </thead> <tbody> <tr> <td>4 PLACES</td> <td>± 0.10</td> <td>± 0.004</td> </tr> <tr> <td>3 PLACES</td> <td>± 0.15</td> <td>± 0.006</td> </tr> <tr> <td>2 PLACES</td> <td>± 0.20</td> <td>± 0.008</td> </tr> <tr> <td>1 PLACE</td> <td>± 0.25</td> <td>± 0.010</td> </tr> <tr> <td>0 PLACE</td> <td>± 0.50</td> <td>± 0.020</td> </tr> </tbody> </table>			mm	INCH	4 PLACES	± 0.10	± 0.004	3 PLACES	± 0.15	± 0.006	2 PLACES	± 0.20	± 0.008	1 PLACE	± 0.25	± 0.010	0 PLACE	± 0.50	± 0.020	DIMENSION STYLE MM ONLY		SCALE 4:1		DESIGN UNITS METRIC		THIRD ANGLE PROJECTION	
		mm	INCH																											
	4 PLACES	± 0.10	± 0.004																											
	3 PLACES	± 0.15	± 0.006																											
2 PLACES	± 0.20	± 0.008																												
1 PLACE	± 0.25	± 0.010																												
0 PLACE	± 0.50	± 0.020																												
DRAFT WHERE APPLICABLE MUST REMAIN WITHIN DIMENSIONS			MATERIAL NO. SEE BOM		DATE MYANSLAMBROU 2012/07/13 VKOSHY 2012/07/19 VKOSHY 2012/07/24		TITLE 12MM 1X4, 1X6 BLADE SEALED ASSEMBLY CABLE SEAL		SHEET NO. 3 OF 11																					
ANGLAR ± 3 °			SIZE D		DOCUMENT NO. SD-34899-6001		molex		THIS DRAWING CONTAINS INFORMATION THAT IS PROPRIETARY TO MOLEX INCORPORATED AND SHOULD NOT BE USED WITHOUT WRITTEN PERMISSION																					
INCORPORATED AND SHOULD NOT BE USED WITHOUT WRITTEN PERMISSION																														

CLIP-SLOT CONFIGURATIONS. FOR PART NUMBERS REFER TO BOM SHEET.

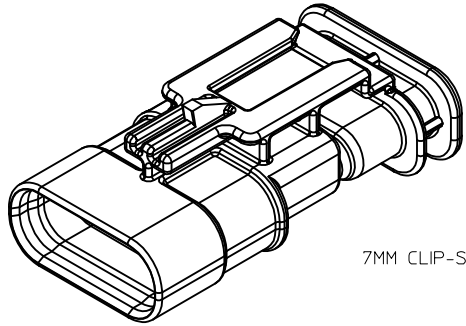

7MM CLIP-SLOT OPTION

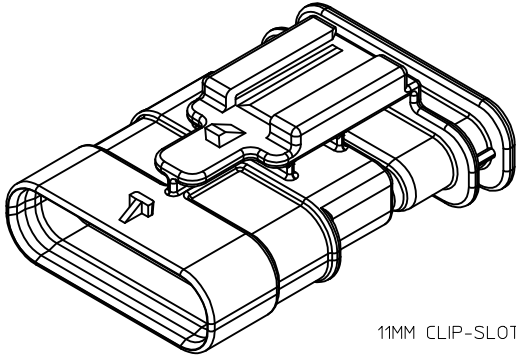
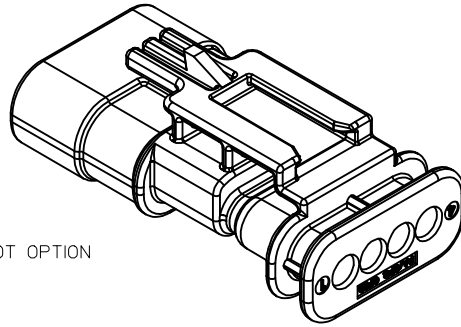

11MM CLIP-SLOT OPTION

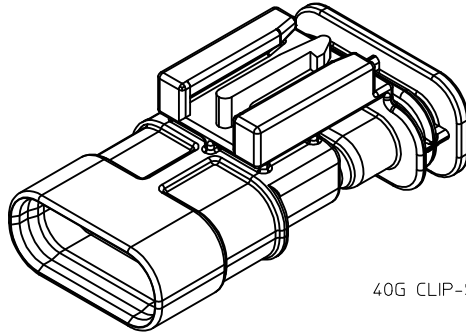
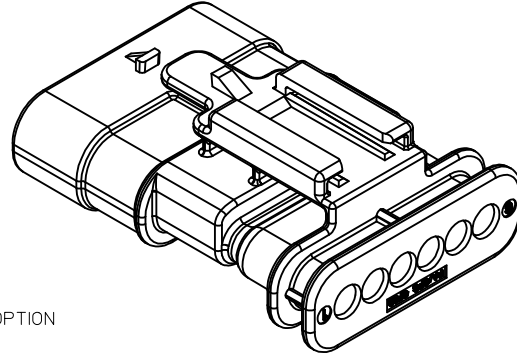

40G CLIP-SLOT OPTION

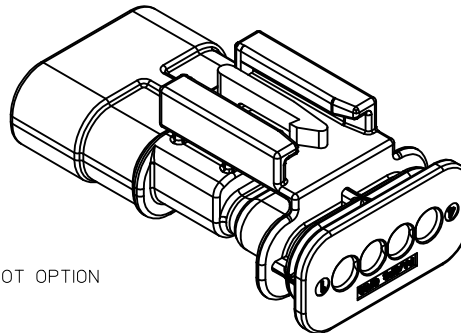

ENTER DESCRIPTION EC NO: UAU2016-1803 DRAWN/KOMALSKY 2016/06/01 CHKD: APPR:KIEKOSKI 2016/06/15 REV:	QUALITY SYMBOLS	GENERAL TOLERANCES (UNLESS SPECIFIED)		DIMENSION STYLE	SCALE	DESIGN UNITS	THIRD ANGLE PROJECTION
	▽=0	mm	INCH	MM ONLY	4:1	METRIC	☉
	▽=0	4 PLACES ± ---	± ---	DRAWN BY MYANSLAMBROU 2012/07/13		DATE	
	▽=0	3 PLACES ± 0.10	± ---	CHECKED BY VKOSHY 2012/07/19		DATE	
	ANGULAR ± 3 °	DRAFT WHERE APPLICABLE MUST REMAIN WITHIN DIMENSIONS		APPROVED BY VKOSHY 2012/07/24		DATE	
	SIZE D	SEE BOM		MATERIAL NO.		DOCUMENT NO.	
				SD-34899-6001		SHEET NO. 4 OF 11	

12MM 1X4, 1X6 BLADE SEALED ASSEMBLY CABLE SEAL

molex

THIS DRAWING CONTAINS INFORMATION THAT IS PROPRIETARY TO MOLEX INCORPORATED AND SHOULD NOT BE USED WITHOUT WRITTEN PERMISSION

BLADE SEALED ASSEMBLY

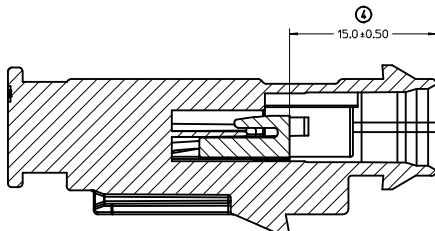
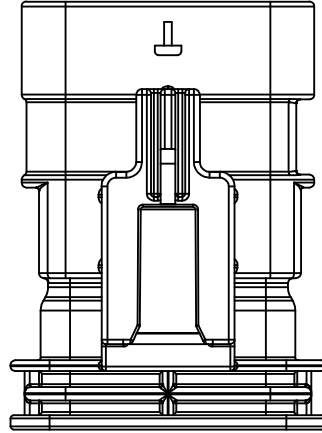
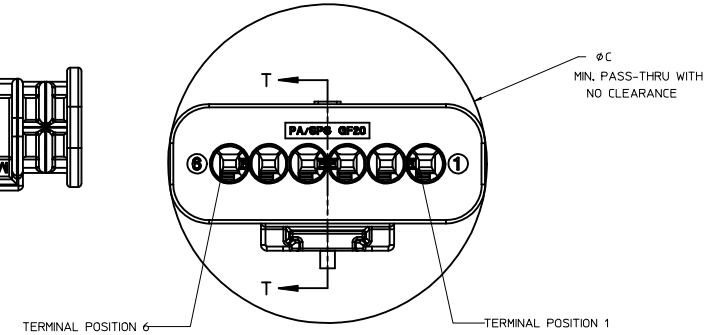
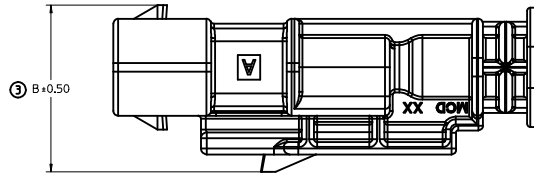
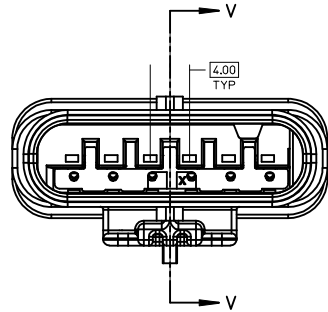
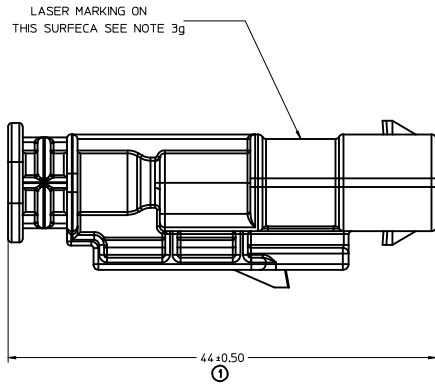

SECTION V-V

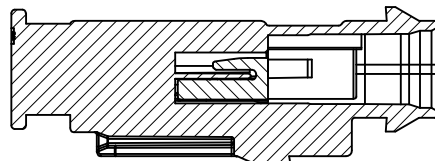

SECTION T-T

PRIMARY LOCK REINFORCEMENT (PLR) SHOWN IN THE PRE-STAGED POSITION

PRIMARY LOCK REINFORCEMENT (PLR) SHOWN IN THE FINAL-LOCK POSITION

1x6 BLADE SEALED ASSEMBLY, 40G CLIP SLOT	17.5	32.75
1x6 BLADE SEALED ASSEMBLY, 11mm CLIP SLOT	16	32.75
1x6 BLADE SEALED ASSEMBLY, 7mm CLIP SLOT	17.25	32.75
1x4 BLADE SEALED ASSEMBLY, 40G CLIP SLOT	17.5	25.25
1x4 BLADE SEALED ASSEMBLY, 11mm CLIP SLOT	16	24.75
1x4 BLADE SEALED ASSEMBLY, 7mm CLIP SLOT	17.25	24.75
CONFIGURATION	B	C

CHARTED DIMENSIONS

ENTER DESCRIPTION EC NO. UAU2016-1803 DRAWN: KOKALSKY 2016/06/01 CHKD: APPR: KOKOSKI 2016/06/15	QUALITY SYMBOLS	GENERAL TOLERANCES (UNLESS SPECIFIED)	DIMENSION STYLE	SCALE	DESIGN UNITS	THIRD ANGLE PROJECTION
	∇=0 ∇=0 ∇=0	mm INCH 4 PLACES ± --- ± --- 3 PLACES ± --- ± --- 2 PLACES ± 0.10 ± --- 1 PLACE ± 0.20 ± --- 0 PLACE ± 0.50 ±	MM ONLY DRAWN BY DATE MYANSLAMBROU 2012/07/13 CHECKED BY DATE VKOSHY 2012/07/19 APPROVED BY DATE VKOSHY 2012/07/24	4:1 METRIC	TITLE 12MM 1X4, 1X6 BLADE SEALED ASSEMBLY CABLE SEAL	MATERIAL NO. SEE BOM
DRAFT WHERE APPLICABLE MUST REMAIN WITHIN DIMENSIONS	ANGULAR ± 3 °	SHEET NO. 5 OF 11	THIS DRAWING CONTAINS INFORMATION THAT IS PROPRIETARY TO MOLEX INCORPORATED AND SHOULD NOT BE USED WITHOUT WRITTEN PERMISSION			

CONNECTION SYSTEM PACKAGING

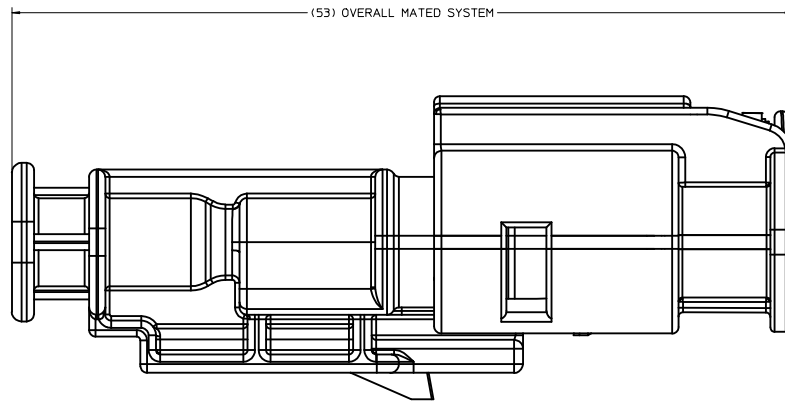

MODEL USED 'AM-120-S-006-1-Z01'

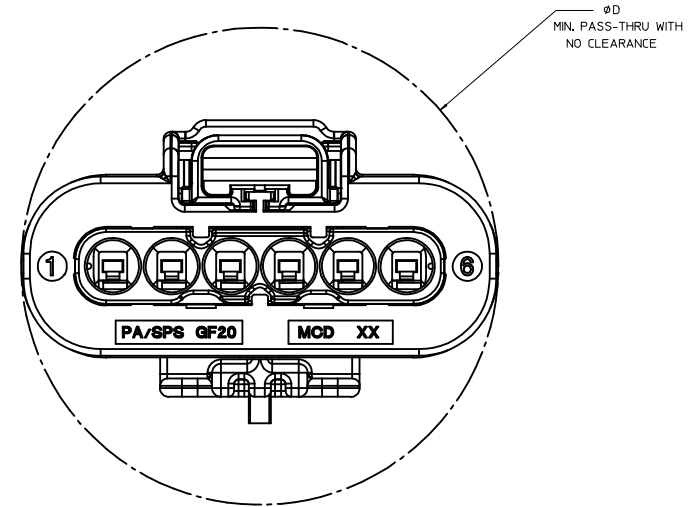

1x6 RECEPTACLE MATED TO 1x6 BLADE, 40 CLIP SLOT	TBD
1x6 RECEPTACLE MATED TO 1x6 BLADE, 11mm CLIP SLOT	33.5
1x6 RECEPTACLE MATED TO 1x6 BLADE, 7mm CLIP SLOT	33.5
1x4 RECEPTACLE MATED TO 1x4 BLADE, 40G CLIP SLOT	25.50
1x4 RECEPTACLE MATED TO 1x4 BLADE, 11mm CLIP SLOT	25.50
1x4 RECEPTACLE MATED TO 1x4 BLADE, 7mm CLIP SLOT	25.50
1.2mm CONNECTION SYSTEM CONFIGURATION	D

CHARTED DIMENSIONS

ENTER DESCRIPTION EC NO: UAU2016-1803 DRAWN: KOWALSKI 2016/06/07 CHKD: APPR: KOEKOGLI 2016/06/15 REV: DESCRIPTION	QUALITY SYMBOLS	GENERAL TOLERANCES (UNLESS SPECIFIED)	DIMENSION STYLE	SCALE	DESIGN UNITS	THIRD ANGLE PROJECTION
	▽=0	mm INCH	MM ONLY	6:1	METRIC	☉
	▽=0	4 PLACES ± --- ± ---	DRAWN BY MYANSLAMBROU 2012/07/13	DATE	TITLE	12MM 1X4, 1X6 BLADE SEALED ASSEMBLY CABLE SEAL
	▽=0	3 PLACES ± --- ± ---	CHECKED BY VKOSHY 2012/07/19	DATE	APPROVED BY VKOSHY 2012/07/24	DATE
	ANGULAR ± 3 °	DRAFT WHERE APPLICABLE MUST REMAIN WITHIN DIMENSIONS	MATERIAL NO. SEE BOM	DOCUMENT NO. SD-34899-6001	SHEET NO. 6 OF 11	
			SIZE D	THIS DRAWING CONTAINS INFORMATION THAT IS PROPRIETARY TO MOLEX INCORPORATED AND SHOULD NOT BE USED WITHOUT WRITTEN PERMISSION		

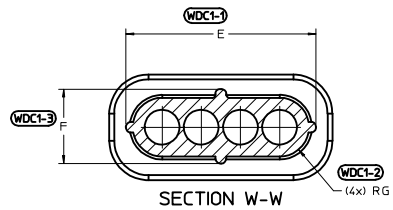

6 CIRCUIT	30.8	10.8	5.4	27.4	7.6	3.0
4 CIRCUIT	22.8	10.8	5.4	19.4	7.6	3.0
CONFIGURATION	A	B	C	E	F	G

CHARTED DIMENSIONS

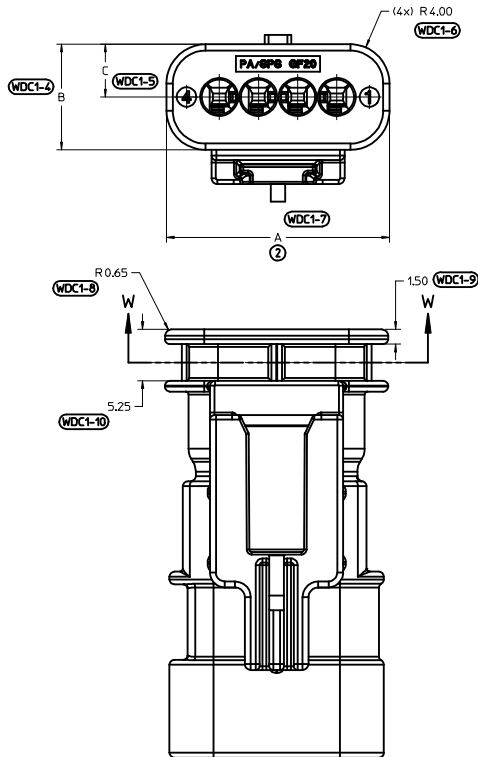

WIRE DRESS COVER
INTERFACE OPTION 1
WIRE DRESS COVERS
NOT AVAILABLE

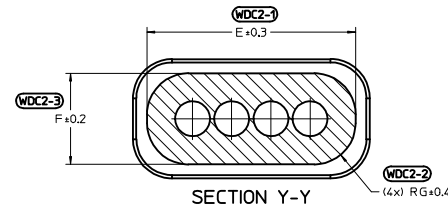

6 CIRCUIT	32.2	12.2	6.1	29.3	9.3	4.2
4 CIRCUIT	24.2	12.2	6.1	21.3	9.3	4.2
CONFIGURATION	A	B	C	E	F	G

CHARTED DIMENSIONS

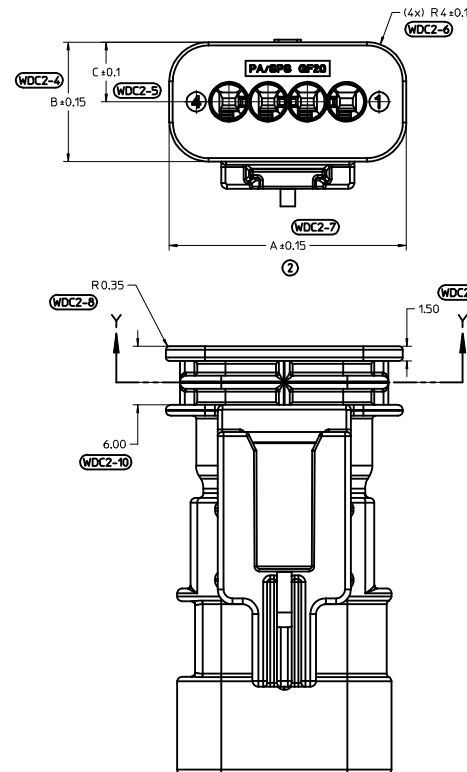

WIRE DRESS COVER
INTERFACE OPTION 2
BASED ON HIRSCHMANN INTERFACE
DRAWING 808-012-xxx REV B5

ENTER DESCRIPTION EC NO. UAU2016-1803 DRAWN/KOMALSKY 2016/06/01 CHKD: APPR:KOEKOSKI 2016/06/15 REV:	QUALITY SYMBOLS	GENERAL TOLERANCES (UNLESS SPECIFIED)	DIMENSION STYLE	SCALE	DESIGN UNITS	THIRD ANGLE PROJECTION	
	▽=0	4 PLACES ± mm ± INCH	MM ONLY	4:1	METRIC	☉	
	▽=0	3 PLACES ± 0.10 ± 0.004					
	▽=0	1 PLACE ± 0.20 ± 0.008					
		0 PLACE ± 0.50 ± 0.020					
		ANGULAR ± 3 °					
		DRAFT WHERE APPLICABLE MUST REMAIN WITHIN DIMENSIONS					
			MATERIAL NO.	DOCUMENT NO.		SHEET NO.	
			SEE TABLE	SD-34899-6001		7 OF 11	
			THIS DRAWING CONTAINS INFORMATION THAT IS PROPRIETARY TO MOLEX INCORPORATED AND SHOULD NOT BE USED WITHOUT WRITTEN PERMISSION				

