



Chipsmall Limited consists of a professional team with an average of over 10 year of expertise in the distribution of electronic components. Based in Hongkong, we have already established firm and mutual-benefit business relationships with customers from,Europe,America and south Asia,supplying obsolete and hard-to-find components to meet their specific needs.

With the principle of "Quality Parts,Customers Priority,Honest Operation,and Considerate Service",our business mainly focus on the distribution of electronic components. Line cards we deal with include Microchip,ALPS,ROHM,Xilinx,Pulse,ON,Everlight and Freescale. Main products comprise IC,Modules,Potentiometer,IC Socket,Relay,Connector.Our parts cover such applications as commercial,industrial, and automotives areas.

We are looking forward to setting up business relationship with you and hope to provide you with the best service and solution. Let us make a better world for our industry!



Contact us

Tel: +86-755-8981 8866 Fax: +86-755-8427 6832

Email & Skype: info@chipsmall.com Web: www.chipsmall.com

Address: A1208, Overseas Decoration Building, #122 Zhenhua RD., Futian, Shenzhen, China



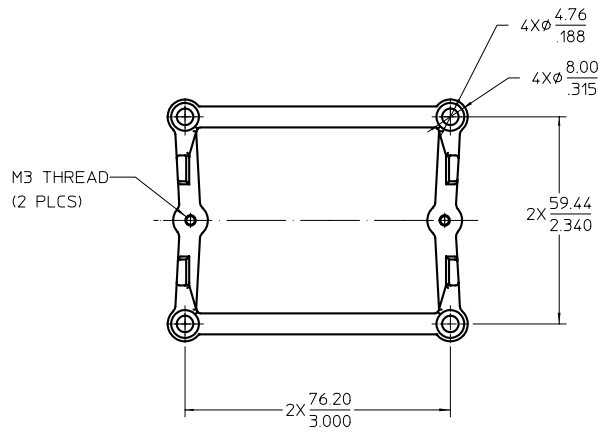

TOP VIEW SHOWN WITHOUT FASTENERS FOR CLARITY

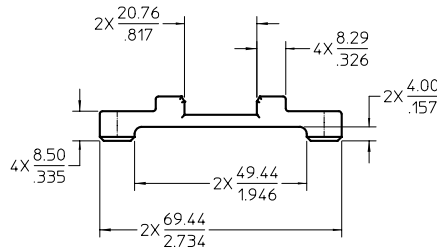
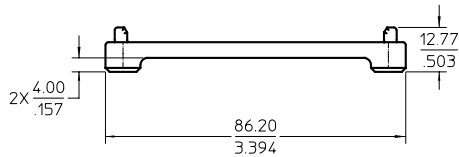

FASTENERS
REFERENCE SD-37223-001

RETENTION FRAME

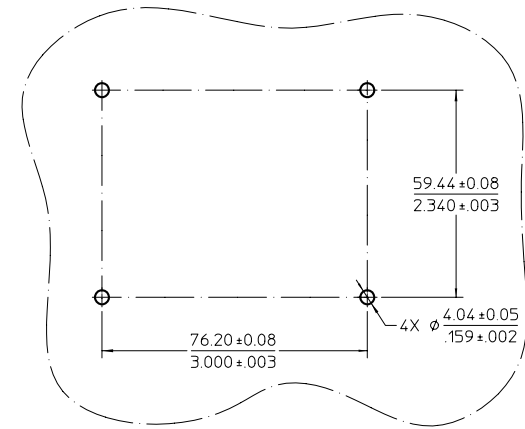
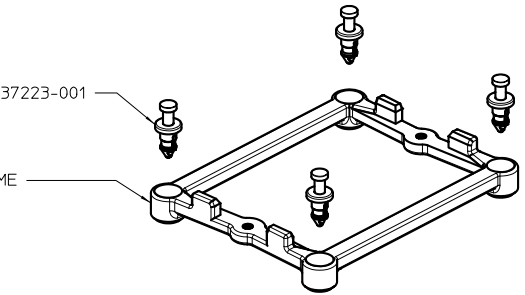

MOTHERBOARD RETENTION HOLE PATTERN

NOTES:

- ALL DIMENSIONS ON THIS DOCUMENT ARE FOR REFERENCE ONLY UNLESS OTHERWISE SPECIFIED.
- MATERIAL: ZINK ALLOY
- RETENTION FRAME USED WITH RADIAL FIN HEAT SINK 37224**** AND 37194****. REFERENCE DRAWING SD-37224-001, SD-37222-001, SD-37194-001, SD-37195-001, AND AS-37222-001.
- FRAME MOUNTS TO MOTHERBOARD WITH ITW FASTEX TUFLOKS™ REFERENCE INTEL RECOMMENDED HOLE PATTERN.
- FASTENERS SHIPPED IN POLYBAGS. 4 FASTENERS PER BAG.
- PARTS TO BE PACKAGED PER PK-37210-001.

CHART:	
MOLEX P/N:	MOUNTING HARDWARE:
372100001	NONE
372101001	TUFLOKS (QTY: 4)

EC NO: USS2002-0008 DRWN:EMERCK 2001/11/13 CHKD:DPICE 2001/11/13 APPR:MOJULLIV 2001/11/13 REV: A	QUALITY SYMBOLS -0 +0	GENERAL TOLERANCES (UNLESS SPECIFIED) 4 PLACES ± --- ± --- 3 PLACES ± --- ± --- 2 PLACES ± --- ± --- 1 PLACE ± --- ± --- ANGULAR ± ---° DRAFT WHERE APPLICABLE MUST REMAIN WITHIN DIMENSIONS	SCALE 1:1 DESIGN UNITS INCH DIMENSION STYLE MM/IN DRAWN BY EMERCK DATE 08/15/01 CHECKED BY DPICE DATE 08/15/01 APPROVED BY DPICE DATE 08/15/01	THIRD ANGLE PROJECTION REVISE ON CAD ONLY	TITLE RETENTION FRAME FOR PENTIUM IV NORTHWOOD CPU MOLEX INCORPORATED DOCUMENT NO. SD-37210-001 SHEET NO. 1 OF 1
	THIS DRAWING CONTAINS INFORMATION THAT IS PROPRIETARY TO MOLEX INCORPORATED AND SHOULD NOT BE USED WITHOUT WRITTEN PERMISSION.				
	MOLEX INCORPORATED				
	SEE CHART				