



Chipsmall Limited consists of a professional team with an average of over 10 year of expertise in the distribution of electronic components. Based in Hongkong, we have already established firm and mutual-benefit business relationships with customers from,Europe,America and south Asia,supplying obsolete and hard-to-find components to meet their specific needs.

With the principle of "Quality Parts,Customers Priority,Honest Operation,and Considerate Service",our business mainly focus on the distribution of electronic components. Line cards we deal with include Microchip,ALPS,ROHM,Xilinx,Pulse,ON,Everlight and Freescale. Main products comprise IC,Modules,Potentiometer,IC Socket,Relay,Connector.Our parts cover such applications as commercial,industrial, and automotives areas.

We are looking forward to setting up business relationship with you and hope to provide you with the best service and solution. Let us make a better world for our industry!



Contact us

Tel: +86-755-8981 8866 Fax: +86-755-8427 6832

Email & Skype: info@chipsmall.com Web: www.chipsmall.com

Address: A1208, Overseas Decoration Building, #122 Zhenhua RD., Futian, Shenzhen, China



NO. OF CIRC. "XX"	DIM. "A"		DIM. "B"		ASSEMBLY MAT. NO. (STD)	ASSEMBLY MAT. NO. (-50)
02	24.5	0.97	11.11	0.438	387351102	387351502
04	46.8	1.84	33.34	1.313	387351104	387351504
07	80.1	3.15	66.68	2.625	387351107	387351507
10	113.4	4.47	100.01	3.938	387351110	387351510
19	213.5	8.40	200.03	7.875	387351119	387351519

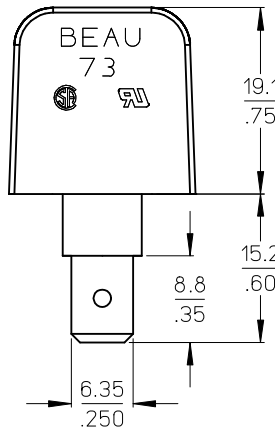
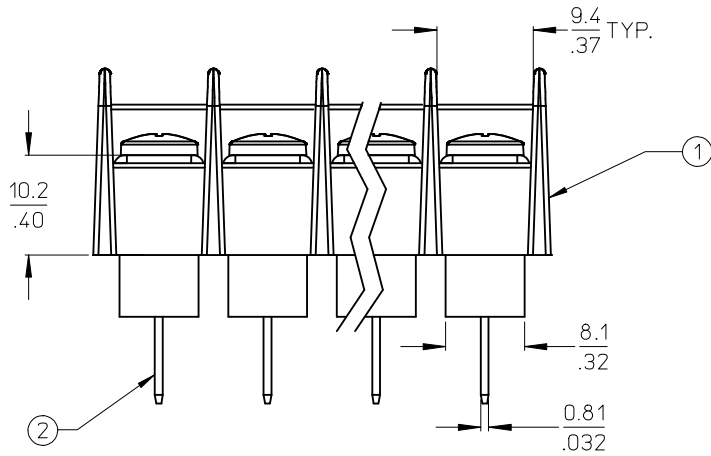
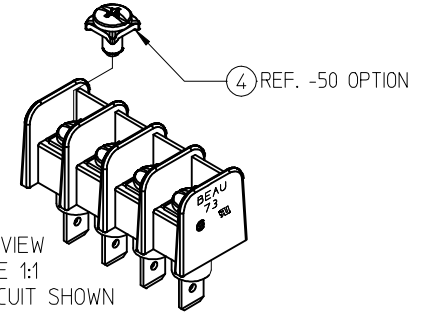
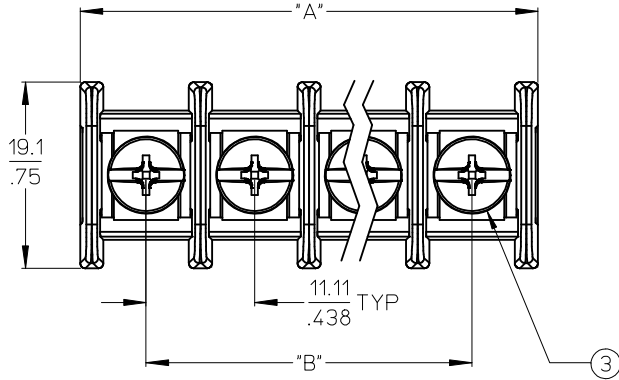

NOTES:

1. MATERIAL: SEE TABLE.
2. FINISHES: SEE TABLE.
3. "XX" REFERS TO THE QUANTITY OF CIRCUITS.
4. ROHS COMPLIANT.

ITEM	QTY.	DESCRIPTION	MATERIAL	FINISH
4	XX	SCREW AND WASHER, #6-32, PAN PHSL(-50 OPT)	STEEL	ZN, CLEAR CHROMATE
3	XX	SCREW, #6-32, BIND. HEAD, PHSL (STD OPT)	STEEL	ZN, CLEAR CHROMATE
2	XX	TERMINAL, FAST TAB	BRASS	TIN PLATE
1	1	CS INSULATOR, SINGLE ROW	POLYESTER (PBT)	BLACK

INITIAL RELEASE
 EC NO: WNA2009-0426
 DRWN: JENCINAS 2009/02/06
 CHKD: CYORK 2009/02/10
 APPR: JMACNEIL 2009/02/10

QUALITY SYMBOLS
 ▽=0
 ▽=0

	GENERAL TOLERANCES (UNLESS SPECIFIED)	
	mm	INCH
4 PLACES	± ---	± ---
3 PLACES	± ---	± .005
2 PLACES	± 0.13	± .01
1 PLACE	± 0.3	± ---
ANGULAR ± 2 °		

DRAFT WHERE APPLICABLE MUST REMAIN WITHIN DIMENSIONS

DIMENSION STYLE: MM/IN
 SCALE: 2:1
 DESIGN UNITS: INCH
 THIRD ANGLE PROJECTION
 DRAWN BY: JENCINAS DATE: 2009/01/20
 CHECKED BY: CYORK DATE: 2009/01/22
 APPROVED BY: JMACNEIL DATE: 2009/01/23
 MATERIAL NO.: SEE CHART

TITLE: 11.11MM [.438] SR BTS, CS FAST TAB ASY NO MTG. ENDS
 MOLEX INCORPORATED
 DOCUMENT NO.: SD-38735-006
 SHEET NO.: 1 OF 1

THIS DRAWING CONTAINS INFORMATION THAT IS PROPRIETARY TO MOLEX INCORPORATED AND SHOULD NOT BE USED WITHOUT WRITTEN PERMISSION