



Chipsmall Limited consists of a professional team with an average of over 10 year of expertise in the distribution of electronic components. Based in Hongkong, we have already established firm and mutual-benefit business relationships with customers from,Europe,America and south Asia,supplying obsolete and hard-to-find components to meet their specific needs.

With the principle of "Quality Parts,Customers Priority,Honest Operation,and Considerate Service",our business mainly focus on the distribution of electronic components. Line cards we deal with include Microchip,ALPS,ROHM,Xilinx,Pulse,ON,Everlight and Freescale. Main products comprise IC,Modules,Potentiometer,IC Socket,Relay,Connector.Our parts cover such applications as commercial,industrial, and automotives areas.

We are looking forward to setting up business relationship with you and hope to provide you with the best service and solution. Let us make a better world for our industry!



Contact us

Tel: +86-755-8981 8866 Fax: +86-755-8427 6832

Email & Skype: info@chipsmall.com Web: www.chipsmall.com

Address: A1208, Overseas Decoration Building, #122 Zhenhua RD., Futian, Shenzhen, China



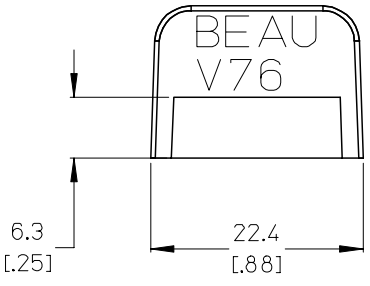
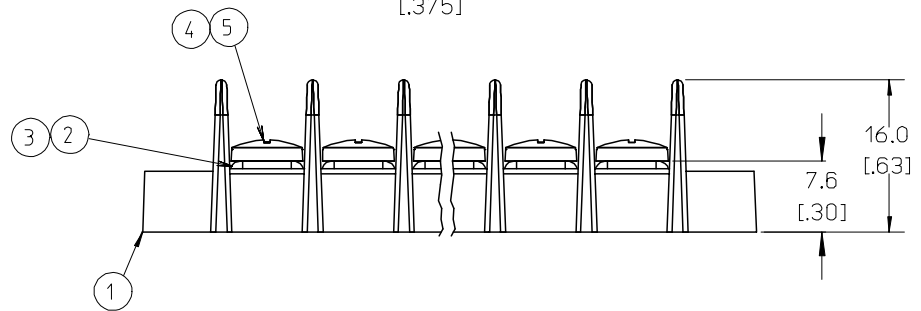
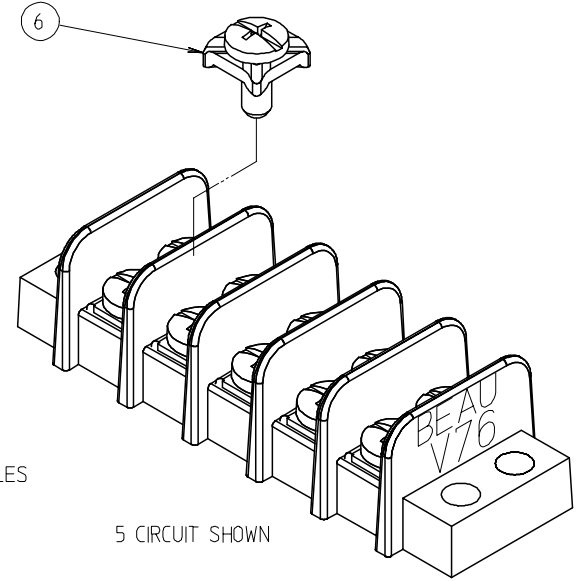
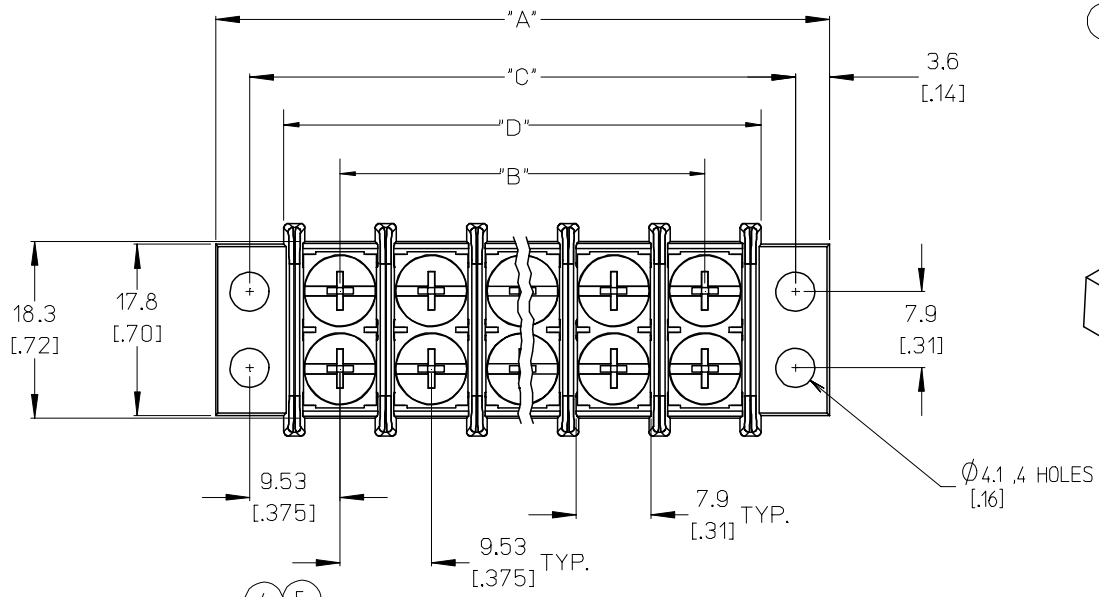

- NOTES:
 1. MATERIAL: SEE TABLE
 2. FINISHES: SEE TABLE
 3. PRODUCT SPECIFICATION: NOT REQUIRED
 4. PACKAGING: NOT REQUIRED
 5. MATES WITH: NONE
 6. 'XX' REFERS TO THE QUANTITY OF CIRCUITS.
 7. INCH DIMENSIONS ARE SHOWN IN BRACKETS [XXX].
 8. ASSEMBLY IS ROHS COMPLIANT.

©

6	XX*2	SCREW, #6-32X.250, PAN HD, PH-SL W/WSHR (-50 OPTION)	STEEL	ZINC W/CHROMATE
5	XX*2	SCREW, #6-32X.250, BGHD, PHIL-SLOT (-49 OPTION)	BRASS	NICKEL
4	XX*2	SCREW, #6-32X.250, BGHD, PHIL-SLOT (STANDARD)	STEEL	ZINC W/CHROMATE
3	XX	TERMINAL PLATE (-49 OPTION)	BRASS	TIN
2	XX	TERMINAL PLATE	BRASS	NICKEL
1	1	INSULATOR	THERMOPLASTIC	BLACK
ITEM	QTY	DESCRIPTION	MATERIAL	FINISH

ADDED -49 & -50 OPTION
 EC NO: ETC2007-0195
 DRW: NEHLE 2006/11/13
 CHKD: JMACNEIL 2006/11/13
 APPR: JMACNEIL 2006/11/13

QUALITY SYMBOLS
 ▽=0
 ▽=0

GENERAL TOLERANCES (UNLESS SPECIFIED)	
	mm
4 PLACES	± ---
3 PLACES	± 0.038
2 PLACES	± 0.13
1 PLACE	± 0.3
ANGULAR ± 2 °	
DRAFT WHERE APPLICABLE MUST REMAIN WITHIN DIMENSIONS	

DIMENSION STYLE	
MM/IN	
DRAWN BY	DATE
R. KEMP	2002/10/10
CHECKED BY	DATE
P. WALTZ	2002/10/14
APPROVED BY	DATE
L. ROTHHAUS	2002/10/14
MATERIAL NO.	
SEE CHART	

SCALE	DESIGN UNITS	THIRD ANGLE PROJECTION
2:1	INCH	
TITLE		
9.53MM [.375] DOUBLE ROW BTS ASSEMBLY		
MATERIAL NO.		
SD-38760-001		
DOCUMENT NO.		SHEET NO.
SD-38760-001		1 OF 2
THIS DRAWING CONTAINS INFORMATION THAT IS PROPRIETARY TO MOLEX INCORPORATED AND SHOULD NOT BE USED WITHOUT WRITTEN PERMISSION		

F
E
D
C
B
A

NO. OF CIRCUITS "XX"	DIM. "A"	DIM. "B"	DIM. "C"	DIM. "D"	ASSEMBLY MATERIAL NO. (STANDARD)	ASSEMBLY MATERIAL NO. (-49 OPTION)	ASSEMBLY MATERIAL NO. (-50 OPTION)
2	35.7 [1.41]	9.53 [.375]	28.6 [1.13]	21.3 [.84]	38760-0102	387600202	387600302
3	45.2 [1.78]	19.05 [.750]	38.1 [1.50]	30.8 [1.21]	38760-0103	387600203	387600303
4	54.7 [2.16]	28.58 [1.125]	47.6 [1.88]	40.3 [1.59]	38760-0104	387600204	387600304
5	64.3 [2.53]	38.10 [1.500]	57.2 [2.25]	49.8 [1.96]	38760-0105	387600205	387600305
6	73.8 [2.91]	47.63 [1.875]	66.7 [2.63]	59.4 [2.34]	38760-0106	387600206	387600306
7	83.3 [3.28]	57.15 [2.250]	76.2 [3.00]	68.9 [2.71]	38760-0107	387600207	387600307
8	92.8 [3.66]	66.68 [2.625]	85.7 [3.38]	78.4 [3.09]	38760-0108	387600208	387600308
9	102.4 [4.03]	76.20 [3.000]	95.3 [3.75]	87.9 [3.46]	38760-0109	387600209	387600309
10	111.9 [4.41]	85.73 [3.375]	104.8 [4.13]	97.5 [3.84]	38760-0110	387600210	387600310
11	121.4 [4.78]	95.25 [3.750]	114.3 [4.50]	107.0 [4.21]	38760-0111	387600211	387600311
12	130.9 [5.16]	104.78 [4.125]	123.8 [4.88]	116.5 [4.59]	38760-0112	387600212	387600312
13	140.5 [5.53]	114.30 [4.500]	133.4 [5.25]	126.0 [4.96]	38760-0113	387600213	387600313
14	150.0 [5.91]	123.83 [4.875]	142.9 [5.63]	135.6 [5.34]	38760-0114	387600214	387600314
15	159.5 [6.28]	133.35 [5.250]	152.4 [6.00]	145.1 [5.71]	38760-0115	387600215	387600315
16	169.0 [6.66]	142.88 [5.625]	161.9 [6.38]	154.6 [6.09]	38760-0116	387600216	387600316
17	178.6 [7.03]	152.40 [6.000]	171.5 [6.75]	164.1 [6.46]	38760-0117	387600217	387600317
18	188.1 [7.41]	161.93 [6.375]	181.0 [7.13]	173.7 [6.84]	38760-0118	387600218	387600318
19	197.6 [7.78]	171.45 [6.750]	190.5 [7.50]	183.2 [7.21]	38760-0119	387600219	387600319
20	207.1 [8.16]	180.98 [7.125]	200.0 [7.88]	192.7 [7.59]	38760-0120	387600220	387600320
21	216.7 [8.53]	190.50 [7.500]	209.6 [8.25]	202.2 [7.96]	38760-0121	387600221	387600321
22	226.2 [8.91]	200.03 [7.875]	219.1 [8.63]	211.8 [8.34]	38760-0122	387600222	387600322
23	235.7 [9.28]	209.55 [8.250]	228.6 [9.00]	221.3 [8.71]	38760-0123	387600223	387600323
24	245.2 [9.66]	219.08 [8.625]	238.1 [9.38]	230.8 [9.09]	38760-0124	387600224	387600324
25	254.8 [10.03]	228.60 [9.000]	247.7 [9.75]	240.3 [9.46]	38760-0125	387600225	387600325
26	264.3 [10.41]	238.13 [9.375]	257.2 [10.13]	249.9 [9.84]	38760-0126	387600226	387600326
27	273.8 [10.78]	247.65 [9.750]	266.7 [10.50]	259.4 [10.21]	38760-0127	387600227	387600327
28	283.3 [11.16]	257.18 [10.125]	276.2 [10.88]	268.9 [10.59]	38760-0128	387600228	387600328
29	292.9 [11.53]	266.70 [10.500]	285.8 [11.25]	278.4 [10.96]	38760-0129	387600229	387600329
30	302.4 [11.91]	276.23 [10.875]	295.3 [11.63]	288.0 [11.34]	38760-0130	387600230	387600330

© ©

ADDED -49 & -50 OPTION EC NO: ETC2007-0195 DRW: NEHLE 2006/11/13 CHKD: IMACNEIL 2006/11/13 APPR: IMACNEIL 2006/11/13	QUALITY SYMBOLS ▽=0 ▽=0	GENERAL TOLERANCES (UNLESS SPECIFIED)		DIMENSION STYLE		SCALE	DESIGN UNITS	THIRD ANGLE PROJECTION	
				MM/IN		2:1	INCH		
				DRAWN BY DATE		TITLE			
				R. KEMP 2002/10/10					
		CHECKED BY DATE		MOLEX INCORPORATED					
		P. WALTZ 2002/10/14							
		APPROVED BY DATE		DOCUMENT NO.					
		L. ROTHSAUS 2002/10/14							
		MATERIAL NO.		SHEET NO.					
		SEE CHART		SD-38760-001		2 OF 2			
		DRAFT WHERE APPLICABLE MUST REMAIN WITHIN DIMENSIONS		THIS DRAWING CONTAINS INFORMATION THAT IS PROPRIETARY TO MOLEX INCORPORATED AND SHOULD NOT BE USED WITHOUT WRITTEN PERMISSION					