



Chipsmall Limited consists of a professional team with an average of over 10 year of expertise in the distribution of electronic components. Based in Hongkong, we have already established firm and mutual-benefit business relationships with customers from,Europe,America and south Asia,supplying obsolete and hard-to-find components to meet their specific needs.

With the principle of “Quality Parts,Customers Priority,Honest Operation,and Considerate Service”,our business mainly focus on the distribution of electronic components. Line cards we deal with include Microchip,ALPS,ROHM,Xilinx,Pulse,ON,Everlight and Freescale. Main products comprise IC,Modules,Potentiometer,IC Socket,Relay,Connector.Our parts cover such applications as commercial,industrial, and automotives areas.

We are looking forward to setting up business relationship with you and hope to provide you with the best service and solution. Let us make a better world for our industry!



## Contact us

Tel: +86-755-8981 8866 Fax: +86-755-8427 6832

Email & Skype: info@chipsmall.com Web: www.chipsmall.com

Address: A1208, Overseas Decoration Building, #122 Zhenhua RD., Futian, Shenzhen, China



# SPECIFICATION FOR APPROVAL



TO: \_\_\_\_\_

PART NO.		REV.		DELTA SAMPLE ISSUE NO	
PART NAME	EMI FILTER			DELTA MODEL	03SB3SM
ORDER P/N.	03SB3SM			SAMPLE ISSUE DATE	

1. ELECTRICAL CHARACTERISTICS:

- 1-1. VOLTAGE RATING ..... 115/250VAC
- 1-2. CURRENT RATING
  - 3. AT 115VAC ..... 3 A RMS Max.
  - B. AT 250VAC ..... 3 A RMS Max.
- 1-3. OPERATING FREQUENCY..... 50/60 Hz
- 1-4. LEAKAGE CURRENT: EACH LINE TO GROUND
  - A. @115VAC 60Hz ..... 2.0 uA Max.
  - B. @250VAC 50Hz ..... 5.0 uA Max.
- 1-5. HIPOT RATING (FOR ONE MINUTE)
  - A. LINE TO GROUND ..... 2250VDC
  - B. LINE TO LINE ..... 1450VDC
- 1-6. TEMPERATURE RANGE: -25 TO +85 DEGREE C
- 1-7. MINIMUM INSERTION LOSS IN dB: (AT 50 OHM SYSTEM)

FREQ. MHz	.01	.05	.10	.15	.50	1.0	5.0	10	30
COM. MODE dB	/	12	18	20	25	25	25	20	10
DIF. MODE dB	/	0	2	4	12	15	25	25	20

1-8. SAFETY

REPORT BY	CHECKED BY	APPROVED BY	3	
			2	
			REV.1	

**DELTA ELECTRONICS, INC.**

186 RUEY KUANG ROAD, NEIHU. TAIPEI 114,  
 TAIWAN, R.O.C.  
 TEL:886-2-87972088 FAX:886-2-87972120

# SPECIFICATION FOR APPROVAL



TO: \_\_\_\_\_

PART NO.		REV.		DELTA SAMPLE ISSUE NO	
PART NAME	EMI FILTER		DELTA MODEL	03SB3SM	
ORDER P/N.	03SB3SM		SAMPLE ISSUE DATE		

## 2. PHYSICAL DIMENSIONS:

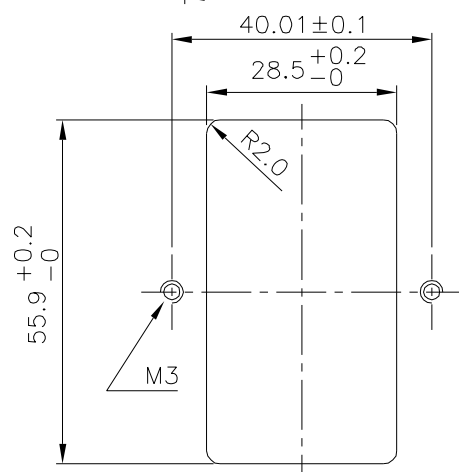
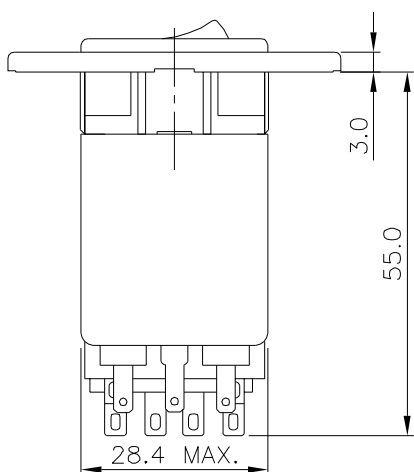
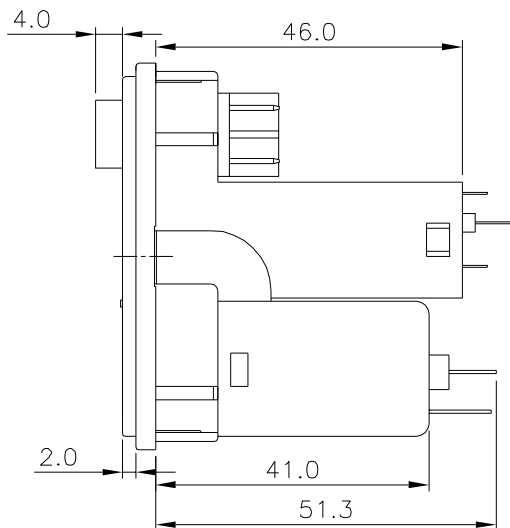
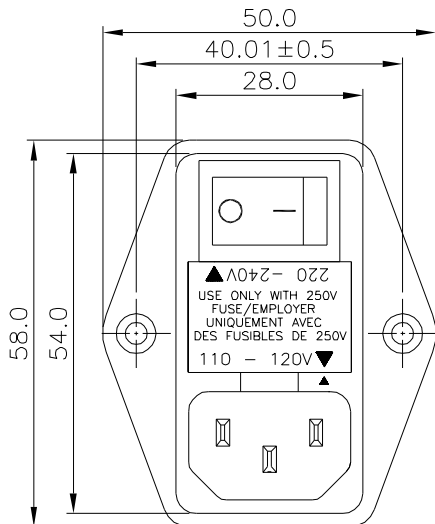

UNIT: mm

SUGGESTED MOUNTING CUTOUT  
(MOUNTING FROM FRONT)

## 3. ELECTRICAL SCHEMATIC:

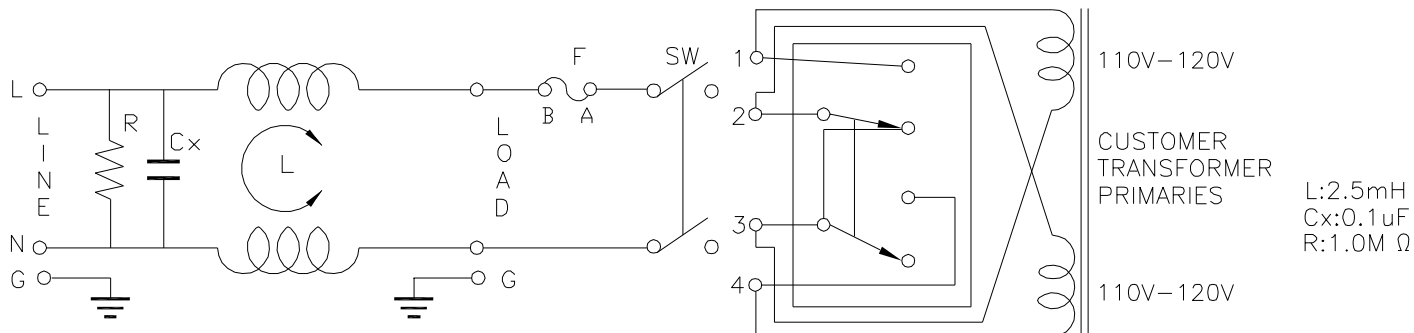

REPORT BY	CHECKED BY	APPROVED BY	UNLESS OTHERWISE SPECIFIED DIMENSION TOLERANCE DCEIMALS .X± 1.0 .XX± ANGLES±		
			REV.	S00	