



Chipsmall Limited consists of a professional team with an average of over 10 year of expertise in the distribution of electronic components. Based in Hongkong, we have already established firm and mutual-benefit business relationships with customers from,Europe,America and south Asia,supplying obsolete and hard-to-find components to meet their specific needs.

With the principle of “Quality Parts,Customers Priority,Honest Operation,and Considerate Service”,our business mainly focus on the distribution of electronic components. Line cards we deal with include Microchip,ALPS,ROHM,Xilinx,Pulse,ON,Everlight and Freescale. Main products comprise IC,Modules,Potentiometer,IC Socket,Relay,Connector.Our parts cover such applications as commercial,industrial, and automotives areas.

We are looking forward to setting up business relationship with you and hope to provide you with the best service and solution. Let us make a better world for our industry!



Contact us

Tel: +86-755-8981 8866 Fax: +86-755-8427 6832

Email & Skype: info@chipsmall.com Web: www.chipsmall.com

Address: A1208, Overseas Decoration Building, #122 Zhenhua RD., Futian, Shenzhen, China



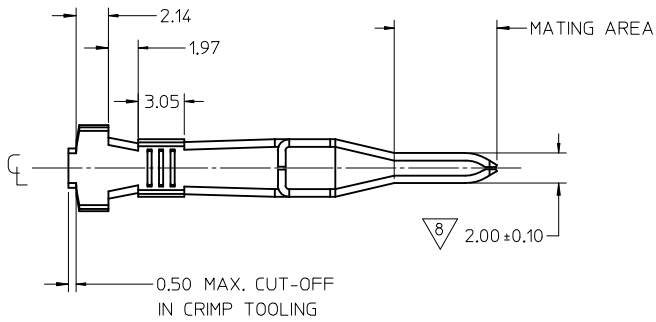

- NOTES:
- MATERIAL: COPPER ALLOY 151, 0.50mm THICK.
 - PLATING:
 - SELECT GOLD: 0.00076 MIN. SELECT. GOLD IN CONTACT AREA, 0.00254 MIN. SELECT *TIN IN CRIMP AREA, OVER 0.00127 NICKEL.
 - SELECT SILVER: 0.00254 MIN. SELECT. SILVER IN CONTACT AREA, 0.00254 MIN. SELECT *TIN IN CRIMP AREA, OVER 0.00127 NICKEL.
 - OVERALL TIN: 0.00254 MIN. BRIGHT *TIN OVER 0.00127 MIN. NICKEL
 - PRODUCT SPECIFICATION: PS-42815-001.
 - PACKAGING INFORMATION: PK-42815-001.
 - PART IS DESIGN IN METRIC.
 - TERMINALS FOR USE WITH STRANDED WIRE ONLY, STRANDED TINNED WIRE IS RECOMMENDED.
 - AFTER CRIMPING, THIS DIMENSION = 3.55mm MIN.
 - AFTER CRIMPING, THIS DIMENSION = 2.25mm MAX.
 - CRIMP SPECIFICATION: 638301000.
 - WHEN USING TIN-PLATED TERMINALS FOR APPLICATIONS INVOLVING VIBRATION AND/OR THERMAL CYCLING, MOLEX STRONGLY RECOMMENDS THE USE OF NYE LUBRICANT, NYOGEL 760G, ON THE MATING AREA OF THE TERMINAL. LUBRICANT SHOULD BE APPLIED AFTER THE TERMINALS ARE INSERTED INTO THE HOUSING.
 - PARTS CONFORM TO CLASS 'B' REQUIREMENT OF COSMETIC SPEC PS-45499-002.
 - REFER AS-42815-001 FOR TIN PLATED TERMINALS RECOMMENDED LUBRICATION PROCEDURE.

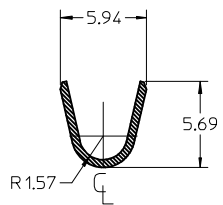
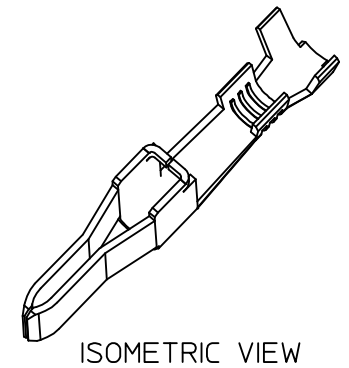
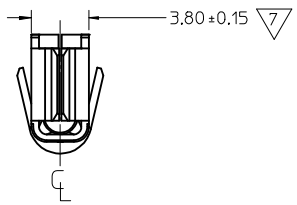
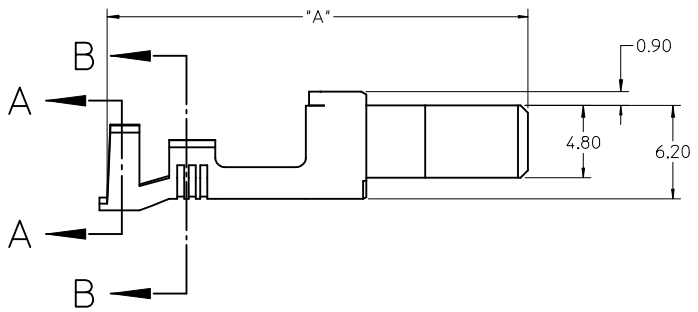

SECTION A-A
INSULATION CRIMP

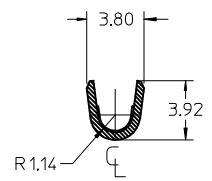

SECTION B-B
CONDUCTOR CRIMP

MATERIAL NO.	CONFIGURATION	DIM. "A"	PLATING	STATUS
42817-0041	STANDARD	27.60	TIN	PLANNED FOR OBSOLESCENCE
42817-0141	MAKE-FIRST/BREAK-LAST	29.60	TIN	PLANNED FOR OBSOLESCENCE
42817-0042	STANDARD	27.60	SELECT GOLD	ACTIVE
42817-0142	MAKE-FIRST/BREAK-LAST	29.60	SELECT GOLD	ACTIVE
42817-1044	STANDARD	27.60	SELECT SILVER	ACTIVE
42817-1144	MAKE-FIRST/BREAK-LAST	29.60	SELECT SILVER	ACTIVE

NEW SILVER PLATING PARTS ADDED DEC NO: UCP2015-2752 DRW: DRWINBR02 CHKD: 2013/12/24 APPR: KPRASAD 2015/02/09	QUALITY SYMBOLS	GENERAL TOLERANCES (UNLESS SPECIFIED)	DIMENSION STYLE MM ONLY	SCALE 4:1	DESIGN UNITS METRIC	THIRD ANGLE PROJECTION
	▽=0	mm INCH	DRAWN BY DATE	TITLE		
	▽=0	4 PLACES ± --- ± ---	MFIRLEJ 2002/05/15	MINIFIT SR. MALE CRIMP TERMINAL, 14-16 AWG		
	▽=0	3 PLACES ± --- ± ---	CHECKED BY DATE			
	2 PLACES ± 0.25 ± ---	JCOMERC I 2002/05/15				
	1 PLACE ± 0.40 ± ---	APPROVED BY DATE	DOCUMENT NO.			
	0 PLACE ± ±	JCOMERC I 2002/05/15	SD-42817-020			
	ANGULAR ±1/2°	MATERIAL NO.	SHEET NO.			
	DRAFT WHERE APPLICABLE MUST REMAIN WITHIN DIMENSIONS	SEE CHART	1 OF 1			
		SIZE	THIS DRAWING CONTAINS INFORMATION THAT IS PROPRIETARY TO MOLEX INCORPORATED AND SHOULD NOT BE USED WITHOUT WRITTEN PERMISSION			