



Chipsmall Limited consists of a professional team with an average of over 10 year of expertise in the distribution of electronic components. Based in Hongkong, we have already established firm and mutual-benefit business relationships with customers from,Europe,America and south Asia,supplying obsolete and hard-to-find components to meet their specific needs.

With the principle of "Quality Parts,Customers Priority,Honest Operation,and Considerate Service",our business mainly focus on the distribution of electronic components. Line cards we deal with include Microchip,ALPS,ROHM,Xilinx,Pulse,ON,Everlight and Freescale. Main products comprise IC,Modules,Potentiometer,IC Socket,Relay,Connector.Our parts cover such applications as commercial,industrial, and automotives areas.

We are looking forward to setting up business relationship with you and hope to provide you with the best service and solution. Let us make a better world for our industry!



## Contact us

Tel: +86-755-8981 8866 Fax: +86-755-8427 6832

Email & Skype: info@chipsmall.com Web: www.chipsmall.com

Address: A1208, Overseas Decoration Building, #122 Zhenhua RD., Futian, Shenzhen, China





# PRODUCT SPECIFICATION

## APPLIANCE APPLICATIONS

### 1.0 SCOPE

This product specification covers 3.18/(.125") X 0.51/(.020") flat blade type connectors in wire-to-wire, wire-to-board, and wire-to-"device" type connections. Two types of connectors are addressed:

- (1) standard – 7.50 mm (.295") centerline spacing series, and
- (2) custom connector housings.

### 2.0 PRODUCT DESCRIPTION

The products described herein are useful in home appliances such as clothes washers, dryers, dish washers, and refrigerators. The terminals have integral secondary locks that, when activated (optional), substantially improve their locking reliability, and virtually eliminate terminal "back-outs." These connectors have long "through air" and "over surface" spacings to resist moisture and other pollutants that are present in appliances. The header assemblies are compatible with surface mount soldering processes.

The terminals crimp to wire insulation with a maximum 4.57 mm (.180") outside diameter, and accommodate standard power cord insulation as well.

The female terminal is fabricated from tin plated C26000. The male tab crimp terminal is fabricated from bare, un-plated C26000. The header terminal is fabricated from tin plated C26000. The male terminals are 3.18/(.125") X 0.51/(.020") tabs that are designed within the limits of the ANSI/NEMA Standards Publication / No. DC 2-1982. The terminations to #18, #16, and #14 AWG wires are accommodated as single crimps. Additionally, #18 AWG wire, UL 1015 only, is accommodated as a double crimp. This is a power connector, but it can be used as a dry circuit connector, too.

(1) Standard – 7.50 mm (.295") Centerline Spacing Series:

The plug and receptacle housings are molded from 66 nylon in its natural color, translucent white, unless otherwise indicated. The header housings are molded from glass filled 46 nylon in a black color. Also, the flammability classification for each housing material is listed below:

<u>PRODUCT NAME:</u>	<u>MATERIAL NUMBER:</u>
PLUG HOUSING, 2 CIRCUIT (UL94V-2), NATURAL	43180-1002
PLUG HOUSING, 2 CIRCUIT (UL94V-2), RED	43180-3002
PLUG HOUSING, 3 CIRCUIT (UL94V-2), NATURAL	43180-1003
PLUG HOUSING, 3 CIRCUIT (UL94V-2), RED	43180-3003
PLUG HOUSING, 3 CIRCUIT (UL94V-2), BLUE	43180-4003
PLUG HOUSING, 4 CIRCUIT (UL94V-2)	X-43180-1004
PLUG HOUSING, 5 CIRCUIT (UL94V-2)	X-43180-1005
PLUG HOUSING, 6 CIRCUIT (UL94V-2)	X-43180-1006
PANEL MOUNT PLUG HOUSING, 2 CIRCUIT (UL94V-2)	X-43384-1002
PANEL MOUNT PLUG HOUSING, 3 CIRCUIT (UL94V-2)	43384-1003
PANEL MOUNT PLUG HOUSING, 4 CIRCUIT (UL94V-2)	X-43384-1004
PANEL MOUNT PLUG HOUSING, 5 CIRCUIT (UL94V-2)	X-43384-1005
PANEL MOUNT PLUG HOUSING, 6 CIRCUIT (UL94V-2)	X-43384-1006

<u>REVISION:</u> <b>4</b>	<u>EGR/ECN INFORMATION:</u> EC No: <b>UCP2005-2735</b> DATE: <b>06/07/2005</b>	<u>TITLE:</u> <b>PRODUCT SPECIFICATION APPLIANCE APPLICATIONS 3.18/(.125) X 0.51/(.020) FLAT BLADE SYSTEM-TPA</b>	<u>SHEET No.</u> <b>1 of 8</b>
<u>DOCUMENT NUMBER:</u> <b>PSX-43335-9999</b>	<u>CREATED / REVISED BY:</u> <b>J.LOWE</b>	<u>CHECKED BY:</u> <b>A.DERR</b>	<u>APPROVED BY:</u> <b>F.SMITH</b>



# PRODUCT SPECIFICATION

## 2.0 PRODUCT DESCRIPTION (CONTINUED):

<u>PRODUCT NAME:</u>	<u>MATERIAL NUMBER:</u>
RECEPTACLE HOUSING, 2 CIRCUIT (UL94V-2), NATURAL	43335-1002
RECEPTACLE HOUSING, 2 CIRCUIT (UL94V-2), BLACK	43335-2002
RECEPTACLE HOUSING, 2 CIRCUIT (UL94V-2), RED	43335-3002
RECEPTACLE HOUSING, 3 CIRCUIT (UL94V-2), NATURAL	43335-1003
RECEPTACLE HOUSING, 3 CIRCUIT (UL94V-2), BLACK	43335-2003
RECEPTACLE HOUSING, 3 CIRCUIT (UL94V-2), RED	43335-3003
RECEPTACLE HOUSING, 3 CIRCUIT (UL94V-2), BLUE	43335-4003
RECEPTACLE HOUSING, 4 CIRCUIT (UL94V-2)	X-43335-1004
RECEPTACLE HOUSING, 5 CIRCUIT (UL94V-2)	X-43335-1005
RECEPTACLE HOUSING, 6 CIRCUIT (UL94V-2)	X-43335-1006
HEADER ASSEMBLY, 2 CIRCUIT, VERTICAL (UL94V-0)	SEE SDA-43160-****
HEADER ASSEMBLY, 3 CIRCUIT, VERTICAL (UL94V-0)	SEE SDA-43160-****
HEADER ASSEMBLY, 4 CIRCUIT, VERTICAL (UL94V-0)	SEE SDA-43160-****
HEADER ASSEMBLY, 5 CIRCUIT, VERTICAL (UL94V-0)	SEE SDA-43160-****
HEADER ASSEMBLY, 6 CIRCUIT, VERTICAL (UL94V-0)	SEE SDA-43160-****
HEADER ASSEMBLY, 2 CIRCUIT, RIGHT ANGLE (UL94V-0)	SEE SDA-43160-****
HEADER ASSEMBLY, 3 CIRCUIT, RIGHT ANGLE (UL94V-0)	SEE SDA-43160-****
HEADER ASSEMBLY, 4 CIRCUIT, RIGHT ANGLE (UL94V-0)	SEE SDA-43160-****
HEADER ASSEMBLY, 5 CIRCUIT, RIGHT ANGLE (UL94V-0)	SEE SDA-43160-****
HEADER ASSEMBLY, 6 CIRCUIT, RIGHT ANGLE (UL94V-0)	SEE SDA-43160-****
MALE TAB CRIMP TERMINAL, SMALL	43178-1001
MALE TAB CRIMP TERMINAL, LARGE	43178-2001
MALE TAB CRIMP TERMINAL, SIDE/SIDE DOUBLE CRIMPS	43178-3001
FEMALE CRIMP TERMINAL, SMALL	43375-0001
FEMALE CRIMP TERMINAL, LARGE	43375-1001

### (2) Custom Connector Housings:

These connector housings are molded from 66 nylon in its natural color, translucent white, unless otherwise indicated. The flammability classification for each connector housing listed below is UL94V-2

<u>PRODUCT NAME:</u>	<u>MATERIAL NUMBER:</u>
3 CIR. PLUG HOUSING (SPECIAL POLARIZATION – COLOR = RED)	43180-0013
3 CIR. PLUG HOUSING (SPECIAL POLARIZATION – COLOR = BLACK)	43180-0023
6 CIRCUIT SWITCH HOUSING (UL94V-2)	43168-1006
24 CIRCUIT APPLIANCE TIMER HOUSING (UL94V-2)	43275-1024
3 CIRCUIT SWITCH HOUSING (UL94V-2)	43301-1003
24 CIR. APPLIANCE TIMER HOUSING (UL94V-2 – COLOR = BLACK)	43796-1024
3 CIR. 7.50 mm HOUSING (CENTER CIRCUIT IS VOIDED)	43335-1103
3 CIR. 7.50 mm HOUSING (SPECIAL POLARIZATION – COLOR = RED)	43335-3013
3 CIR. 7.50 mm HOUSING (SPECIAL POLARIZATION – COLOR = BLUE)	43335-4023
3 CIR. 7.50 mm HOUSING (SPECIAL POLARIZATION – COLOR = BLACK)	43335-5023

<b>REVISION:</b> <b>4</b>	<b>EGR/ECN INFORMATION:</b> EC No: <b>UCP2005-2735</b> DATE: <b>06/07/2005</b>	<b>TITLE:</b> <b>PRODUCT SPECIFICATION</b> <b>APPLIANCE APPLICATIONS</b> <b>3.18/(.125) X 0.51/(.020) FLAT BLADE SYSTEM-TPA</b>	<b>SHEET No.</b> <b>2 of 8</b>
<b>DOCUMENT NUMBER:</b> <b>PSX-43335-9999</b>	<b>CREATED / REVISED BY:</b> <b>J.LOWE</b>	<b>CHECKED BY:</b> <b>A.DERR</b>	<b>APPROVED BY:</b> <b>F.SMITH</b>



# PRODUCT SPECIFICATION

## 3.0 APPLICABLE DOCUMENTS AND SPECIFICATIONS

SEE PRODUCT DRAWING

## 4.0 RATINGS

### 4.1 VOLTAGE

600 volts

Also, 1000 volts, mated, for the standard 7.50 mm (.295") centerline types (wire to wire only)  
Note that this value reverts to 600 volts when the system is not mated; before disconnecting a connector used with a higher potential than 600 volts, the effected leads must be discharged to either ground or to the chassis.

### 4.2 CURRENT AND APPLICABLE WIRES

#### WIRE SIZE – TYPE

18 AWG – UL 1015  
16 AWG – UL 1015  
14 AWG – UL 1015

#### CURRENT LEVEL

12 AMPERES MAXIMUM  
TBD AMPERES MAXIMUM  
15 AMPERES MAXIMUM

### 4.3 TEMPERATURE

-40° centigrade to +75° centigrade

## 5.0 PERFORMANCE

### 5.1 ELECTRICAL REQUIREMENTS

<u>ITEM</u>	<u>TEST CONDITION</u>	<u>REQUIREMENT</u>
VOLTAGE DROP	THE VOLTAGE DIFFERENCE BETWEEN AN UNINTERRUPTED 6" LENGTH OF #18 AWG (UL1015) WIRE, AND THE SAME 6" LENGTH THAT IS INTERRUPTED BY TWO CRIMPED TERMINALS THAT ARE MATED AND HAVE 12.0 AMPERES CURRENT FLOWING. (SEE SHEETS 6 & 7)	0.120 VOLTS MAX (INITIAL)
INSULATION RESISTANCE	MATE CONNECTORS WITH A VOLTAGE OF 500 VDC BETWEEN ADJACENT TERMINALS AND BETWEEN TERMINALS AND GROUND.	1000 MEGOHMS MIN (INITIAL)
DIELECTRIC WITHSTANDING VOLTAGE	MATE CONNECTORS WITH A VOLTAGE OF 5000 VAC FOR 1 MINUTE	NO BREAKDOWN
CONTACT RESISTANCE (LOW LEVEL)	MATE CONNECTORS WITH A MAXIMUM VOLTAGE OF 20 MV AND A CURRENT OF 100 MA.	10.0 MOHMS MAX

<u>REVISION:</u> <b>4</b>	<u>EGR/ECN INFORMATION:</u> EC No: <b>UCP2005-2735</b> DATE: <b>06/07/2005</b>	<u>TITLE:</u> <b>PRODUCT SPECIFICATION APPLIANCE APPLICATIONS 3.18/(.125) X 0.51/(.020) FLAT BLADE SYSTEM-TPA</b>	<u>SHEET No.</u> <b>3 of 8</b>
<u>DOCUMENT NUMBER:</u> <b>PSX-43335-9999</b>	<u>CREATED / REVISED BY:</u> <b>J.LOWE</b>	<u>CHECKED BY:</u> <b>A.DERR</b>	<u>APPROVED BY:</u> <b>F.SMITH</b>



# PRODUCT SPECIFICATION

## 5.2 MECHANICAL REQUIREMENTS

<u>ITEM</u>	<u>TEST CONDITION</u>	<u>REQUIREMENT</u>	
CONNECTOR MATING & UN-MATING FORCE	INSERT AND WITHDRAW CONNECTORS AT A RATE OF 25 +/- 6 mm (1 +/- .250 INCHES) PER MINUTE	MAX INSERT (3.0 LBS)	MIN WITHDRAW (0.5 LBS) PER TERMINAL
TERMINAL RETENTION FORCE IN HOUSING	AXIAL PULL OUT FORCE ON THE TERMINAL IN THE HOUSING AT A RATE OF 25 +/- 6 mm (1 +/- .25 INCHES) PER MINUTE (RECEPTACLE TERMINAL)	20 LBS MIN (TPA NOT ACTIVATED)	25 LBS MIN (WITH TPA ACTIVATED)
TERMINAL RETENTION FORCE IN HOUSING	AXIAL PULL OUT FORCE ON THE TERMINAL IN THE HOUSING AT A RATE OF 25 +/- 6 mm (1 +/- .25 INCHES) PER MINUTE (MALE TAB CRIMP TERMINAL)	30 LBS MIN (TPA NOT ACTIVATED)	30 LBS MIN (WITH TPA ACTIVATED)
VIBRATION	AMPLITUDE: 1.50 mm (.060 IN.) PEAK-TO-PEAK SWEEP: 10-55-10 HZ IN ONE MINUTE DURATION: 2 HOURS IN EACH X-Y-Z AXIS	CONTACT RESISTANCE 10.0 MOHMS MAX NO DISCONTINUITY GREATER THAN ONE MICROSECOND	
MECHANICAL SHOCK	50 G IN THE FORM OF THREE SAW TOOTH WAVEFORM SHOCKS IN EACH X-Y-Z AXIS.	CONTACT RESISTANCE: 10.0 MOHMS MAX NO DISCONTINUITY GREATER THAN ONE MICROSECOND	
WIRE PULL OUT FORCE (AXIAL)	APPLY AN AXIAL PULL OUT FORCE ON THE WIRE AT A RATE OF 25 +/- 6 mm (1 +/- .250 INCHES) PER MIN.	AWG 14 16 18	MIN FORCE 50 LBS 45 LBS 30 LBS
TERMINAL INSERTION FORCE	APPLY AN AXIAL INSERTION FORCE ON THE WIRE AT A RATE OF 25 +/- 6 mm (1 +/- .250 INCHES) PER MIN.	1.5 LBS MAX	

<u>REVISION:</u> <b>4</b>	<u>EGR/ECN INFORMATION:</u> EC No: <b>UCP2005-2735</b> DATE: <b>06/07/2005</b>	<u>TITLE:</u> <b>PRODUCT SPECIFICATION APPLIANCE APPLICATIONS 3.18/(.125) X 0.51/(.020) FLAT BLADE SYSTEM-TPA</b>	<u>SHEET No.</u> <b>4 of 8</b>
<u>DOCUMENT NUMBER:</u> <b>PSX-43335-9999</b>	<u>CREATED / REVISED BY:</u> <b>J.LOWE</b>	<u>CHECKED BY:</u> <b>A.DERR</b>	<u>APPROVED BY:</u> <b>F.SMITH</b>



# PRODUCT SPECIFICATION

## 5.3 ENVIRONMENTAL REQUIREMENTS

<u>ITEM</u>	<u>TEST CONDITION</u>	<u>REQUIREMENT</u>
THERMAL SHOCK	MATED CONNECTORS TO BE EXPOSED TO 25 CYCLES OF:	APPEARANCE: NO DAMAGE
	TEMPERATURE (DEGREES C)      DURATION (MIN.) -55 +0/-3                              30 +3/-0 +85 +3/-0                              30 +3/-0	CONTACT RESISTANCE: 10.0 MOHMS MAX
HUMIDITY (STEADY STATE)	MATED CONNECTORS TO BE EXPOSED TO A TEMPERATURE OF 85 +/- 2 DEGREES C WITH A RELATIVE HUMIDITY OF 90 TO 95% FOR 96 HOURS.	APPEARANCE: NO DAMAGE  CONTACT RESISTANCE: 10.0 MOHMS MAX  DIELECTRIC STRENGTH: NO BREAKDOWN  INSULATION RESISTANCE: 1000 MEGOHMS MIN
HUMIDITY (CYCLIC)	MATED CONNECTORS TO BE EXPOSED TO TEMPERATURE/HUMIDITY CYCLING BETWEEN +25° C AND +65° C AT 95% RH, -10° C WITH HUMIDITY NOT CONTROLLED. (MIL-STD-1344A METHOD 1002.2) (TYPE II)	APPEARANCE: NO DAMAGE  CONTACT RESISTANCE: 10.0 MOHMS MAX  DIELECTRIC STRENGTH: NO BREAKDOWN  INSULATION RESISTANCE: 100 MEGOHMS MIN

**6.0 PACKAGING**  
SEE PRODUCT DRAWING

**7.0 GAGES AND FIXTURES**  
PICTORIALS & SPECIFICATIONS ARE PROVIDED AS NEEDED

<u>REVISION:</u> <b>4</b>	<u>EGR/ECN INFORMATION:</u> EC No: <b>UCP2005-2735</b> DATE: <b>06/07/2005</b>	<u>TITLE:</u> <b>PRODUCT SPECIFICATION APPLIANCE APPLICATIONS 3.18/(.125) X 0.51/(.020) FLAT BLADE SYSTEM-TPA</b>	<u>SHEET No.</u> <b>5 of 8</b>
<u>DOCUMENT NUMBER:</u> <b>PSX-43335-9999</b>	<u>CREATED / REVISED BY:</u> <b>J.LOWE</b>	<u>CHECKED BY:</u> <b>A.DERR</b>	<u>APPROVED BY:</u> <b>F.SMITH</b>



# PRODUCT SPECIFICATION

## 8.0 OTHER INFORMATION

Voltage Drop, and Cycling Test:

Do this test with mated housings (43335-1003 and 43180-1003) both fully loaded with their respective terminals (43375-0001 and 43178-0001). Each terminal shall be crimped to a twelve inch length of #18 AWG, UL1015 wire with white insulation.

The mated connector housings shall lie latch side up and flat atop the test bench, lined up, side by side, and spaced 76.2 mm (3.0") apart. The wires shall be lifted 3.18 mm – 12.70 mm (.125" - .500") above the test bench. Heat sinks (eg. metal nuts and bolts), and heat sources are to be kept far enough away from the test samples so that the connector temperatures are not effected. The wires are to be connected end to end in daisy chain form with the stripped conductor ends twisted together and soldered. See figure #2.

For each mated pair of connector housings there are three wire taps. The wires used in the center position of the mated connector housings (circuit #2) are to be stripped for the voltage taps. See figure #1.

Cycle Test: The mated connector assemblies to be subjected to a 500 hour cycling test comprised of a 45 minute "on" period and 15 minute "off" period. During each "on" period 12.00 +/-0.10 amperes shall be present in the wires of the mated connector housings being tested. During each "off" period, 0.00 amperes to be present (ie. shut off). The voltage data is to be recorded during the last 10 minutes of the "on" period of the specified cycle.

The criterion, voltage drop, is the arithmetic difference between the voltage across the termination ("A"), and the voltage across the uninterrupted 6" length of wire ("B"). The voltage data to be recorded every twenty four cycles, and at the five hundredth cycle.

Requirement: 0.120 volts maximum throughout the test.

REVISION: <b>4</b>	EGR/ECN INFORMATION: EC No: <b>UCP2005-2735</b> DATE: <b>06/07/2005</b>	TITLE: <b>PRODUCT SPECIFICATION APPLIANCE APPLICATIONS 3.18/(.125) X 0.51/(.020) FLAT BLADE SYSTEM-TPA</b>	SHEET No. <b>6 of 8</b>
DOCUMENT NUMBER: <b>PSX-43335-9999</b>	CREATED / REVISED BY: <b>J.LOWE</b>	CHECKED BY: <b>A.DERR</b>	APPROVED BY: <b>F.SMITH</b>



# PRODUCT SPECIFICATION

LOCATION OF VOLTAGE TAPS

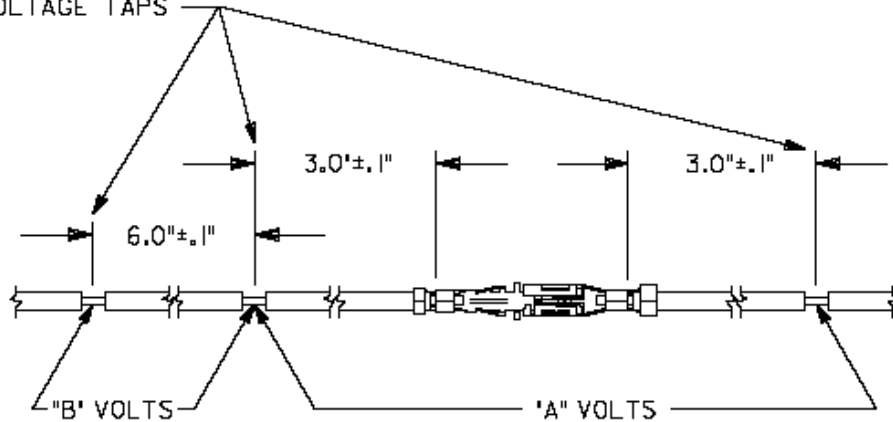

VOLTAGE DROP = (A-B) VOLTS

FIGURE 1

(FULL SCALE)

(APPLIES TO THE CENTER CIRCUIT LOCATION ONLY)

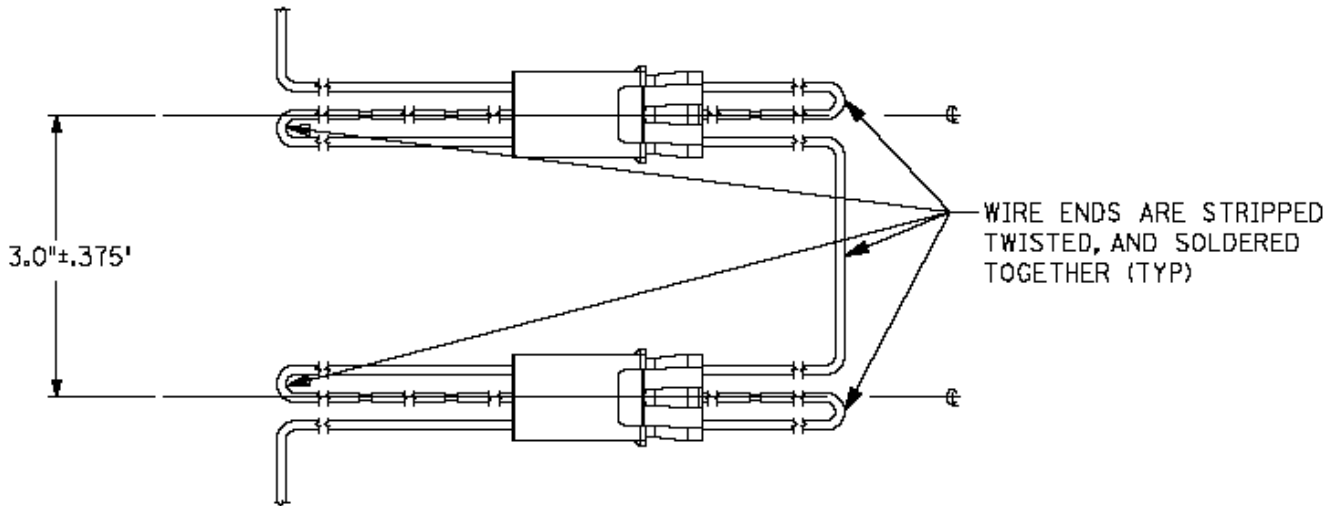

FIGURE 2

(ONE HALF SCALE)

REVISION: <b>4</b>	EGR/ECN INFORMATION: EC No: <b>UCP2005-2735</b> DATE: <b>06/07/2005</b>	TITLE: <b>PRODUCT SPECIFICATION APPLIANCE APPLICATIONS 3.18/(.125) X 0.51/(.020) FLAT BLADE SYSTEM-TPA</b>	SHEET No. <b>7 of 8</b>
DOCUMENT NUMBER: <b>PSX-43335-9999</b>	CREATED / REVISED BY: <b>J.LOWE</b>	CHECKED BY: <b>A.DERR</b>	APPROVED BY: <b>F.SMITH</b>





# PRODUCT SPECIFICATION

LTR	REVISIONS		
"1"	"X" RELEASE PER ECN# U50791	95/02/14	KBP
"2"	REVISED PER ECN# U81258	97/11/25	KBP
"3"	REVISED PER ECN# U81679	98/02/19	KBP
4	ADDED P/N, CONVERTED TO WORD; ECN: UCP2005-2735	05/06/08	JBL

REVISION: <b>4</b>	EGR/ECN INFORMATION: EC No: <b>UCP2005-2735</b> DATE: <b>06/07/2005</b>	TITLE: <b>PRODUCT SPECIFICATION APPLIANCE APPLICATIONS 3.18/(.125) X 0.51/(.020) FLAT BLADE SYSTEM-TPA</b>	SHEET No. <b>8 of 8</b>
DOCUMENT NUMBER: <b>PSX-43335-9999</b>	CREATED / REVISED BY: <b>J.LOWE</b>	CHECKED BY: <b>A.DERR</b>	APPROVED BY: <b>F.SMITH</b>