



Chipsmall Limited consists of a professional team with an average of over 10 year of expertise in the distribution of electronic components. Based in Hongkong, we have already established firm and mutual-benefit business relationships with customers from,Europe,America and south Asia,supplying obsolete and hard-to-find components to meet their specific needs.

With the principle of “Quality Parts,Customers Priority,Honest Operation,and Considerate Service”,our business mainly focus on the distribution of electronic components. Line cards we deal with include Microchip,ALPS,ROHM,Xilinx,Pulse,ON,Everlight and Freescale. Main products comprise IC,Modules,Potentiometer,IC Socket,Relay,Connector.Our parts cover such applications as commercial,industrial, and automotives areas.

We are looking forward to setting up business relationship with you and hope to provide you with the best service and solution. Let us make a better world for our industry!



Contact us

Tel: +86-755-8981 8866 Fax: +86-755-8427 6832

Email & Skype: info@chipsmall.com Web: www.chipsmall.com

Address: A1208, Overseas Decoration Building, #122 Zhenhua RD., Futian, Shenzhen, China



High Frequency Ceramic Solutions

434MHz Impedance-Matched Balun+Filter Integrated Passive Device (IPD) for Silicon Labs EFR32 Chipset, EIA 0805.

0434BM15B0027

Detail Specification: 2/26/2018

Page 1 of 6

Do you need a small sub-GHz or 2.4GHz antenna? Go to: www.johansontechnology.com/antennas

General Specifications

Part Number	0434BM15B0027	
Frequency (MHz)	431 - 437	
Unbalanced Impedance (Ω)	50	
Balanced Impedance (Ω)	Impedance matched to Silicon Labs EFR32	
Insertion Loss (dB)	2.0 typ. (2.3 max)	
Return Loss (dB)	15 typ. (10 min)	
Phase Balance (deg)	-155 ± 15	
Amplitude Difference (dB)	-5.0 ± 2.0	
Attenuation (dB @MHz)	22 typ. (18 min.)	862 - 874 MHz
	35 typ. (30 min.)	1293 - 1311 MHz
Voltage Rating (V)	3.6 max.	
Power Capacity (W)	3 max. CW	
Operating Temperature	-40°C to $+85^{\circ}\text{C}$	

The entire sub-GHz discrete L/C circuit is integrated inside this small package!

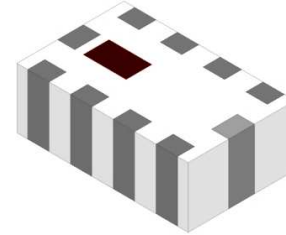

Silicon Labs Approved!

Quantity/Reel	4,000
Storage Temperature Range	-40°C to $+85^{\circ}\text{C}$
Storage Period	18 months max
Recommended Storage Conditions for unused T&R product	$+5 \sim +35^{\circ}\text{C}$, Humidity 45~75%RH, 18 mos. max

For more Silicon Labs matched balun-filters, go to: www.johansontechnology.com/silabs

Part Number Explanation

P/N Suffix	Packing Style	Bulk	Suffix = S	eg. 0434BM15B0027S
		T & R	Suffix = E	eg. 0434BM15B0027E

Mechanical Dimensions

	In	mm
L	0.079 ± 0.008	2.00 ± 0.20
W	0.049 ± 0.008	1.25 ± 0.20
T	0.028 ± 0.004	0.70 ± 0.10
a	0.010 ± 0.004	0.25 ± 0.10
b	0.012 ± 0.006	0.30 ± 0.15
c	$0.008 +0.004/-0.006$	$0.20 +0.1/-0.15$
d	0.020 ± 0.004	0.50 ± 0.10

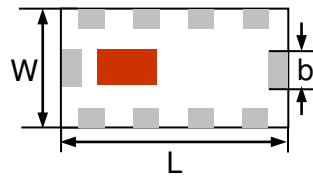

Top

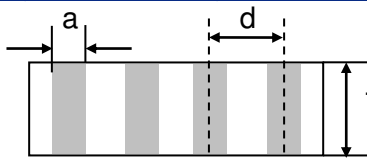

Side

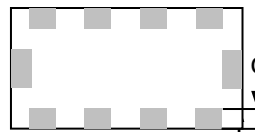

Bottom

Terminal Configuration

No.	Function	No.	Function
1	GND	6	RX_N
2	ANT	7	RX_P
3	GND	8	TX_N
4	GND	9	TX_P
5	GND	10	GND or DC Feed/GND

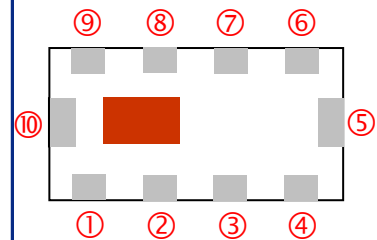

Johanson Technology, Inc. reserves the right to make design changes without notice.

All sales are subject to Johanson Technology, Inc. terms and conditions.



www.johansontechnology.com

4001 Calle Tecate • Camarillo, CA 93012 • TEL 805.389.1166 FAX 805.389.1821

Ver. 1.0

2018 Johanson Technology, Inc. All Rights Reserved

High Frequency Ceramic Solutions

434MHz Impedance-Matched Balun+Filter Integrated Passive Device (IPD) for Silicon Labs EFR32 Chipset, EIA 0805.

0434BM15B0027

Detail Specification: 2/26/2018

Page 2 of 6

Pad-Soldermask Guidelines (with DC Feed)

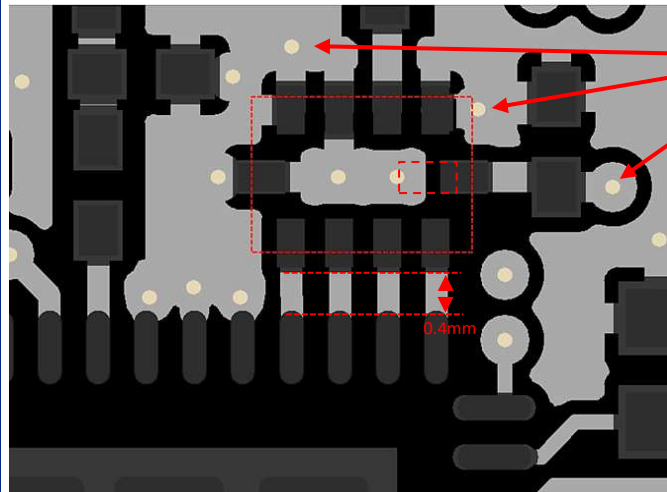

GND vias are crucial for filter harmonic attenuation

- GND
- Solder Pads
- GND via (ϕ 0.20)

For reference design package and PCB CAD files, please contact us at:
www.johansontechnology.com/ask-a-question

PCB Reference Design Schematic

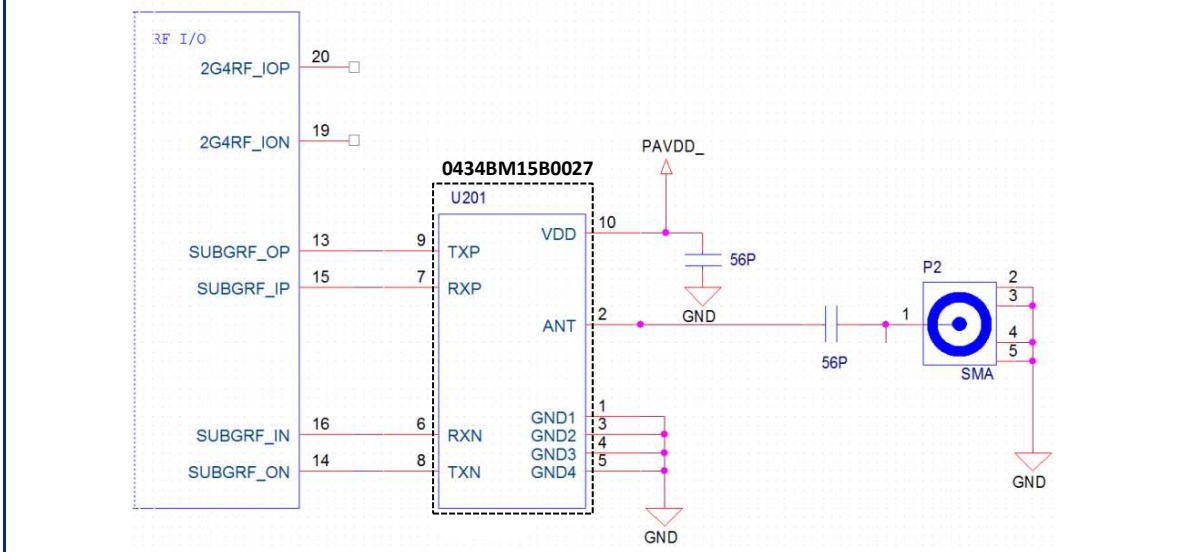

Johanson Technology, Inc. reserves the right to make design changes without notice.
 All sales are subject to Johanson Technology, Inc. terms and conditions.



www.johansontechnology.com
 4001 Calle Tecate • Camarillo, CA 93012 • TEL 805.389.1166 FAX 805.389.1821
 Ver. 1.0 2018 Johanson Technology, Inc. All Rights Reserved

High Frequency Ceramic Solutions

434MHz Impedance-Matched Balun+Filter Integrated Passive Device (IPD) for Silicon Labs EFR32 Chipset, EIA 0805.

0434BM15B0027

Detail Specification: 2/26/2018

Page 3 of 6

Measuring Diagram

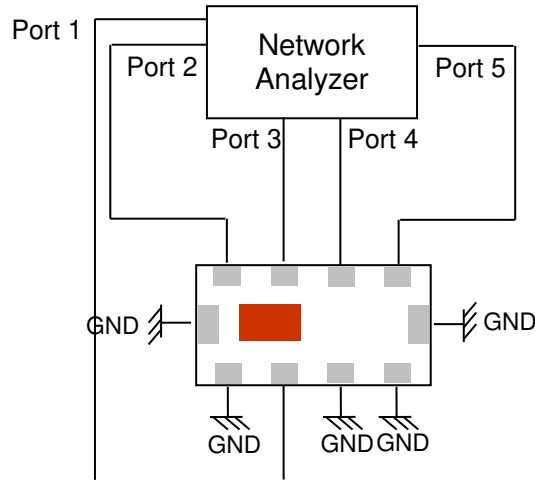

Tx mode:

Port 1 impedance: 50Ω

Port 2 and 3 impedance*: Complex conjugate to EFR32 $Z_{IC,TX\ on}$

Port 4 and 5 impedance*: Load impedance of EFR32 $Z_{IC,RX\ off}$

$$IL=TX\ S_{DS21}$$

$$RL=TX\ S_{SS11} / TX\ S_{DD22}$$

$$\text{Amplitude Difference} = dB(S(1,2)/S(1,3))$$

$$\text{Phase Balance} = \text{Phase}(S(1,2)/S(1,3))$$

Rx mode:

Port 1 impedance: 50Ω

Port 4 and 5 impedance*: Complex conjugate to EFR32 $Z_{IC,RX\ on}$

Port 2 and 3 impedance*: Load impedance of EFR32 $Z_{IC,TX\ off}$

$$IL=RX\ S_{DS21}$$

$$RL=RX\ S_{SS11} / RX\ S_{DD22}$$

$$\text{Amp_balance} = dB(S(1,4)/S(1,5))$$

$$\text{Phase_balance} = \text{Phase}(S(1,4)/S(1,5))$$

*Termination impedance included in s-parameters

Johanson Technology, Inc. reserves the right to make design changes without notice.

All sales are subject to Johanson Technology, Inc. terms and conditions.



www.johansontechnology.com

4001 Calle Tecate • Camarillo, CA 93012 • TEL 805.389.1166 FAX 805.389.1821

Ver. 1.0

2018 Johanson Technology, Inc. All Rights Reserved

High Frequency Ceramic Solutions

434MHz Impedance-Matched Balun+Filter Integrated Passive Device (IPD) for Silicon Labs EFR32 Chipset, EIA 0805.

0434BM15B0027

Detail Specification: 2/26/2018

Page 4 of 6

Typical Electrical Characteristics (T=25°C)

Transmit Mode Insertion Loss, Return Loss, and Attenuation

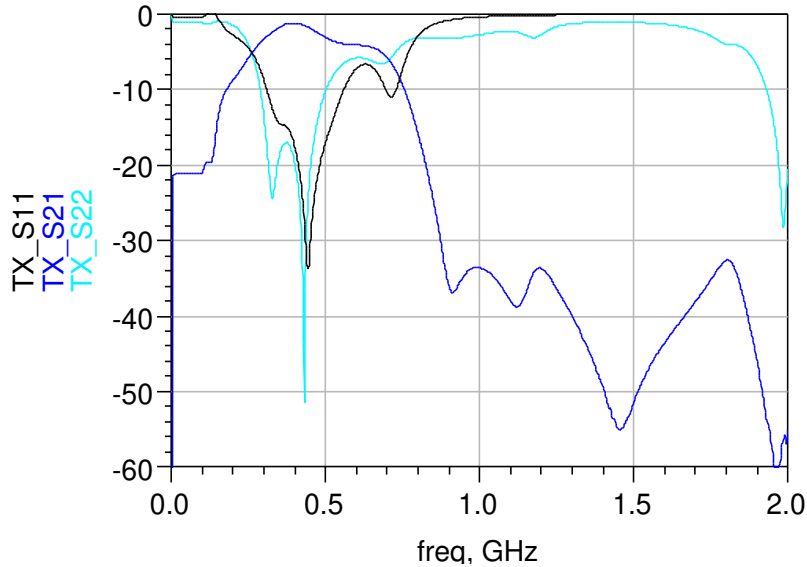

Transmit Mode Phase Balance, Amplitude Difference

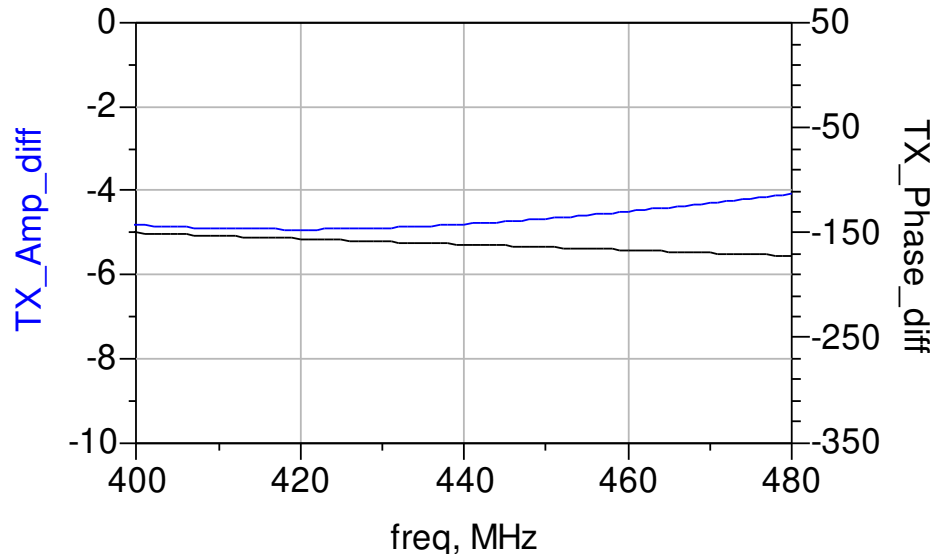

Johanson Technology, Inc. reserves the right to make design changes without notice.

All sales are subject to Johanson Technology, Inc. terms and conditions.



High Frequency Ceramic Solutions

434MHz Impedance-Matched Balun+Filter Integrated Passive Device (IPD) for Silicon Labs EFR32 Chipset, EIA 0805.

0434BM15B0027

Detail Specification: 2/26/2018

Page 5 of 6

Typical Electrical Characteristics (T=25°C)

Receive Mode Insertion Loss, Return Loss, and Attenuation

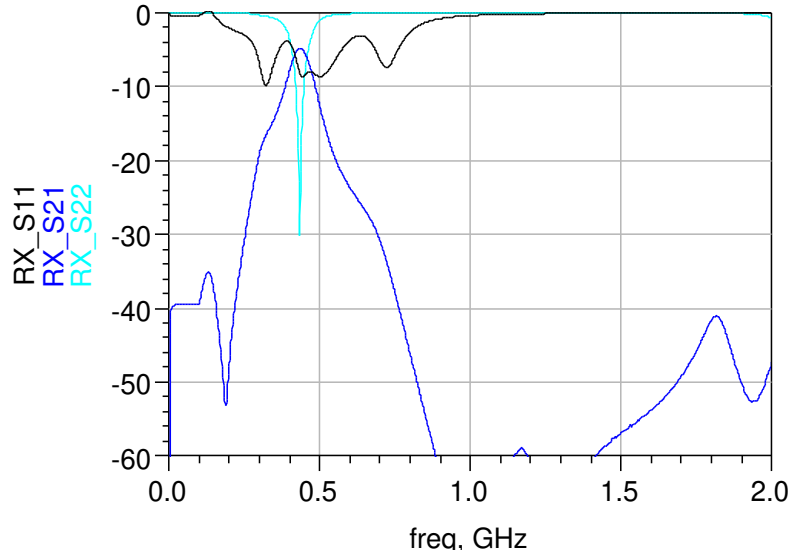

Receive Mode Phase Balance, Amplitude Difference

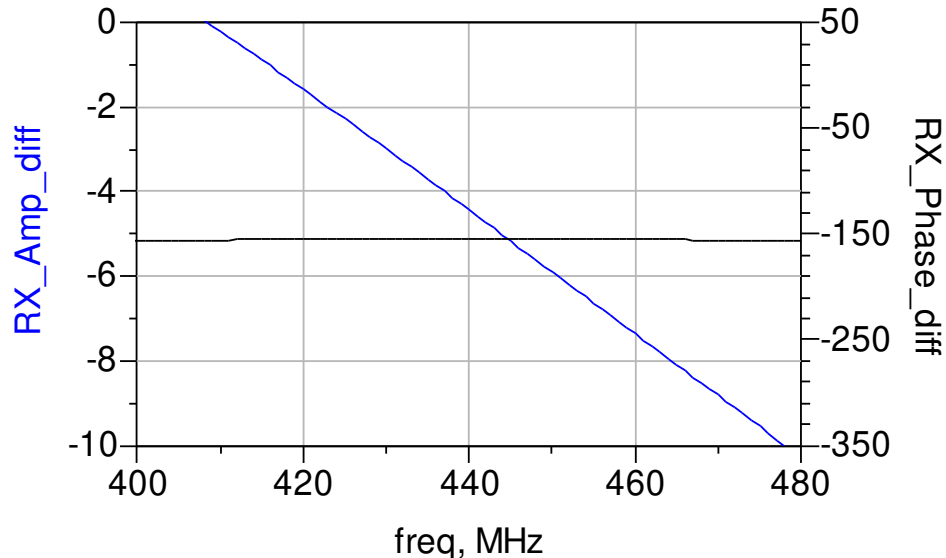

Johanson Technology, Inc. reserves the right to make design changes without notice.
All sales are subject to Johanson Technology, Inc. terms and conditions.



www.johansontechnology.com
4001 Calle Tecate • Camarillo, CA 93012 • TEL 805.389.1166 FAX 805.389.1821
Ver. 1.0 2018 Johanson Technology, Inc. All Rights Reserved

High Frequency Ceramic Solutions

434MHz Impedance-Matched Balun+Filter Integrated Passive Device (IPD) for Silicon Labs EFR32 Chipset, EIA 0805.

0434BM15B0027

Detail Specification: 2/26/2018

Page 6 of 6

Application Notes, Layout Files, and more

www.johansontechnology.com/silabs

Small SMD 433MHz (or 900M, 2.4G, 5G) antennas

www.johansontechnology.com/antennas

RoHS Compliance

www.johansontechnology.com/rohs-compliance

Soldering Information

www.johansontechnology.com/ipcsoldering-profile

Antenna layout and tuning techniques

www.johansontechnology.com/tuning

Antenna layout review, tuning, and characterization services

www.johansontechnology.com/ipc-antenna-services

MSL Info

www.johansontechnology.com/msl-rating

Recommended Storage Condition and Max Shelf Life

www.johansontechnology.com/recommended-storage-conditions

Packaging information

www.johansontechnology.com/tape-reel-packaging

Terminal Pad Composition

100% Tin (Sn)

Would you like us to review your layout for free? Need an embedded antenna recommendation for your application?

Contact us at:

www.johansontechnology.com/ask-a-question

Johanson Technology, Inc. reserves the right to make design changes without notice.

All sales are subject to Johanson Technology, Inc. terms and conditions.



www.johansontechnology.com
4001 Calle Tecate • Camarillo, CA 93012 • TEL 805.389.1166 FAX 805.389.1821

Ver. 1.0

2018 Johanson Technology, Inc. All Rights Reserved