



Chipsmall Limited consists of a professional team with an average of over 10 year of expertise in the distribution of electronic components. Based in Hongkong, we have already established firm and mutual-benefit business relationships with customers from,Europe,America and south Asia,supplying obsolete and hard-to-find components to meet their specific needs.

With the principle of "Quality Parts,Customers Priority,Honest Operation,and Considerate Service",our business mainly focus on the distribution of electronic components. Line cards we deal with include Microchip,ALPS,ROHM,Xilinx,Pulse,ON,Everlight and Freescale. Main products comprise IC,Modules,Potentiometer,IC Socket,Relay,Connector.Our parts cover such applications as commercial,industrial, and automotives areas.

We are looking forward to setting up business relationship with you and hope to provide you with the best service and solution. Let us make a better world for our industry!



Contact us

Tel: +86-755-8981 8866 Fax: +86-755-8427 6832

Email & Skype: info@chipsmall.com Web: www.chipsmall.com

Address: A1208, Overseas Decoration Building, #122 Zhenhua RD., Futian, Shenzhen, China



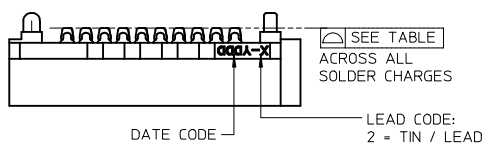
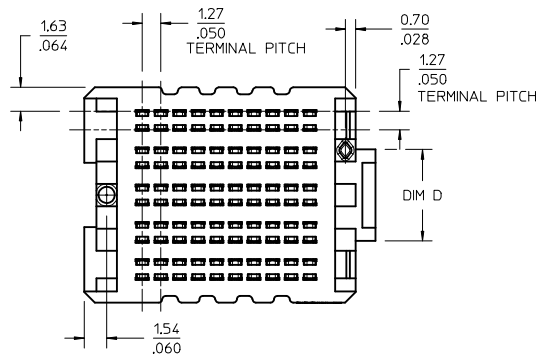

10 ROW
10 POSITION
SHOWN

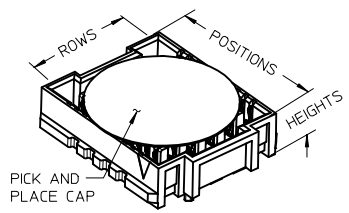
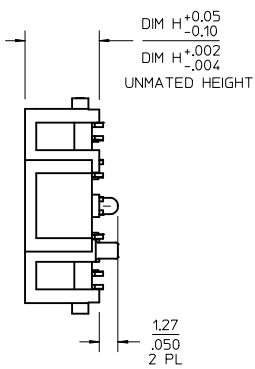
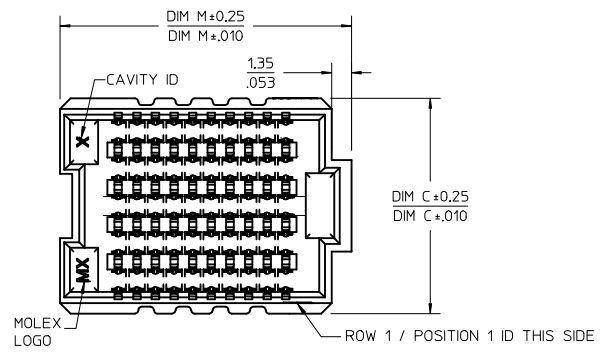

POSITION	
10	0.15/.006
20	0.15/.006
30	0.15/.006
40	0.15/.006
50	0.15/.006
15	0.15/.006
25	0.15/.006
35	0.23/.009
45	0.23/.009

SEE SHEET 3 FOR
6 ROW GEOMETRY

NOTES:

- MATERIALS: HOUSING: LCP, GLASS FILLED, UL94V-0, BLACK
CONTACTS: COPPER ALLOY
SOLDER CHARGE: 63% TIN, 37% LEAD
- FINISH: SELECT GOLD IN CONTACT AREA: 30 MICRINCH MINIMUM
SELECT TIN IN TAIL, 50 MICRINCH MINIMUM
OVERALL - NICKEL UNDERPLATE OVERALL
- PRODUCT SPECIFICATION: PS-45970-001
- PACKAGING SPECIFICATION: TAPE AND REEL PACK PK-45971-002
- MATES WITH SEARAY PLUG ASSEMBLY 45970
- APPLICATION SPECIFICATION: AS-45970-001
- COSMETIC SPECIFICATION: PS-45499-002 CLASS B
- PART STATUS: CONTACT MOLEX

INITIAL RELEASE EC NO: UCP2015-1206 DRAWN: RWHIPPLE 2014/10/23 CHKD: DMORGAN 2014/10/23 APPR: SMILLER 2015/01/05	QUALITY SYMBOLS $\nabla = 0$ $\nabla = 0$ $\nabla = 0$	GENERAL TOLERANCES (UNLESS SPECIFIED) mm INCH 4 PLACES ± --- ± --- 3 PLACES ± --- ± .010 2 PLACES ± 0.25 ± .015 1 PLACE ± 0.38 ± --- 0 PLACE ± ±	DIMENSION STYLE MM/IN DRAWN BY DATE RWHIPPLE 2014/10/23 CHECKED BY DATE DMORGAN 2014/10/24 APPROVED BY DATE SMILLER 2015/01/05	SCALE 3:1 DESIGN UNITS INCH	THIRD ANGLE PROJECTION
	TITLE SEARAY RECEPTACLE ASSEMBLY, TIN/LEAD 1.27/.050 CENTERS				
	MATERIAL NO. SEE TABLES SHT 4 DOCUMENT NO. RSD-45971-001 SHEET NO. 1 OF 4				
	DRAFT WHERE APPLICABLE MUST REMAIN WITHIN DIMENSIONS THIS DRAWING CONTAINS INFORMATION THAT IS PROPRIETARY TO MOLEX INCORPORATED AND SHOULD NOT BE USED WITHOUT WRITTEN PERMISSION				

10 9 8 7 6 5 4 3 2 1

NO OF ROWS	DIM C	DIM D	DIM E
8	12.14/.478	3.70/.146	4.44/.175
10	14.68/.578	6.24/.246	5.71/.225

10 ROW
10 POSITION
SHOWN

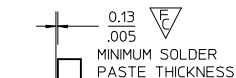
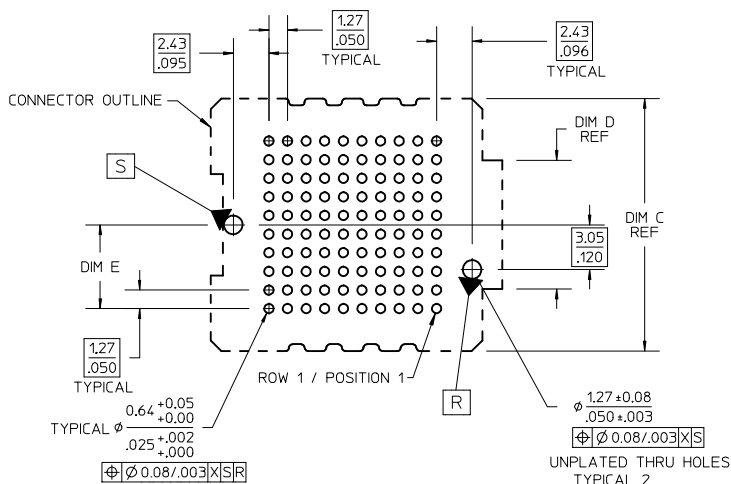

RECOMMENDED PCB LAYOUT: COMPONENT SIDE
SOLDER SCREEN APERTURE SIZE: .089/.035 DIAMETER
PCB THICKNESS: NA

		DIM R RECEPTACLE STACK HEIGHT					
		MM	5.0	6.0	6.5	7.5	8.0
DIM P PLUG STACK HEIGHT	2.0	7.0	8.0	8.5	9.5	10.0	10.0
	3.0	8.0	9.0	9.5	10.5	11.0	11.0
	3.5	8.5	9.5	10.0	11.0	11.5	11.5
	2.5	7.5	8.5	9.0	10.0	10.5	10.5
	4.5	9.5	10.5	11.0	12.0	12.5	12.5
	5.0	10.0	11.0	11.5	12.5	13.0	13.0
	7.0	12.0	13.0	13.5	14.5	15.0	15.0

MATED STACK HEIGHTS
GIVEN IN MILLIMETERS (MM) FOR REFERENCE ONLY

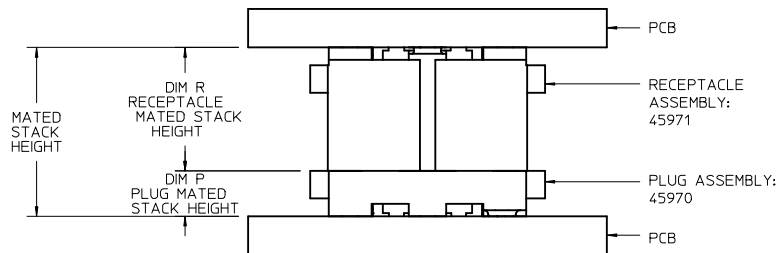

MATED STACK HEIGHTS
GIVEN IN MILLIMETERS (MM) FOR REFERENCE ONLY

SEE SHEET 1 EC NO: UCP2015-1206 DRWN:RWHIPPLE 2014/10/23 CHKD:DMORGAN 2014/10/23 APPR:SMILLER 2015/01/05	QUALITY SYMBOLS	GENERAL TOLERANCES (UNLESS SPECIFIED)	DIMENSION STYLE	SCALE	DESIGN UNITS	THIRD ANGLE PROJECTION
	$\nabla/\text{E}=0$ $\nabla/\text{E}=2$ $\nabla/\text{E}=0$	mm	MM/IN	3:1	INCH	
		INCH	DRAWN BY	DATE	TITLE	
		4 PLACES ± --- ± ---	RWHIPPLE	2014/10/23	SEARAY RECEPTACLE ASSEMBLY, TIN/LEAD 1.27/.050 CENTERS	
		3 PLACES ± --- ± .010	CHECKED BY	DATE		
		2 PLACES ± 0.25 ± .015	DMORGAN	2014/10/24		
		1 PLACE ± 0.38 ± ---	APPROVED BY	DATE		
		0 PLACE ± ±	SMILLER	2015/01/05		
		ANGULAR ± --- °	MATERIAL NO.	DOCUMENT NO.		
		DRAFT WHERE APPLICABLE MUST REMAIN WITHIN DIMENSIONS	SEE TABLES SHT 4	RSD-45971-001		SHEET NO. 2 OF 4
			SIZE B	THIS DRAWING CONTAINS INFORMATION THAT IS PROPRIETARY TO MOLEX INCORPORATED AND SHOULD NOT BE USED WITHOUT WRITTEN PERMISSION		

9 8 7 6 5 4 3 2 1

CONNECTOR OUTLINE

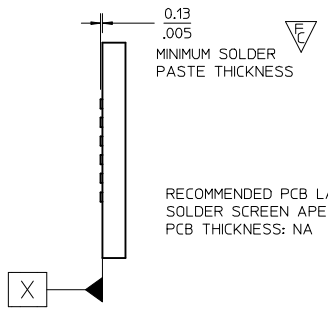
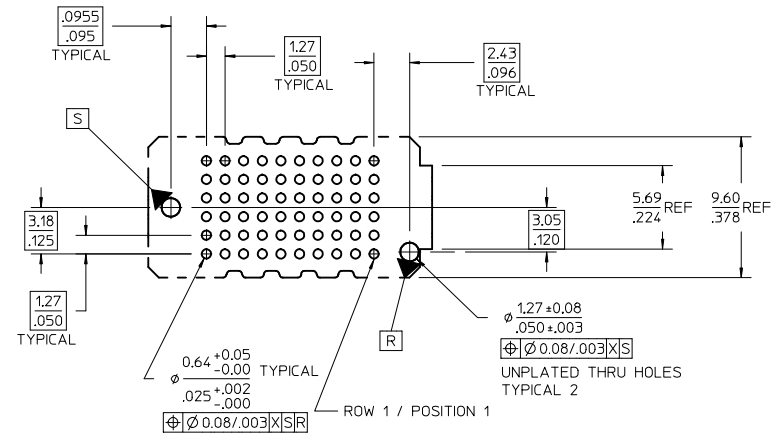

RECOMMENDED PCB LAYOUT: COMPONENT SIDE
 SOLDER SCREEN APERTURE SIZE: .089/.035
 PCB THICKNESS: NA

6 ROW GEOMETRY

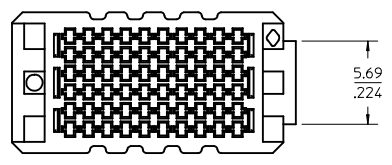
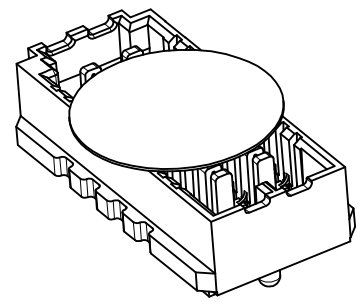
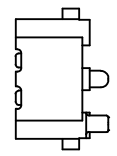
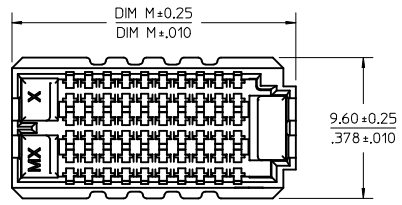
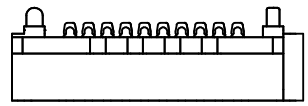

SEE SHEET 1 EC NO: UCP2015-1206 DRAWN: RWHIPPLE 2014/10/23 CHKD: DMORGAN 2014/10/23 APPR: SMILLER 2015/01/05	REV A	DESCRIPTION QUALITY SYMBOLS ▽=0 ▽=2 ▽=0	GENERAL TOLERANCES (UNLESS SPECIFIED)		DIMENSION STYLE MM/IN		SCALE 3:1	DESIGN UNITS INCH	THIRD ANGLE PROJECTION		
									TITLE SEARAY RECEPTACLE ASSEMBLY, TIN/LEAD 1.27/.050 CENTERS molex		
			4 PLACES	± ---	± ---	DRAWN BY	DATE				
			3 PLACES	± ---	± .010	CHECKED BY	DATE				
2 PLACES	± 0.25	± .015	DMORGAN	2014/10/24							
1 PLACE	± 0.38	± ---	APPROVED BY	DATE							
0 PLACE	±	±	SMILLER	2015/01/05							
ANGULAR ± --- ° DRAFT WHERE APPLICABLE MUST REMAIN WITHIN DIMENSIONS			MATERIAL NO.	DOCUMENT NO.	SHEET NO.						
			SEE TABLES SHT 4	RSD-45971-001	3 OF 4						
			THIS DRAWING CONTAINS INFORMATION THAT IS PROPRIETARY TO MOLEX INCORPORATED AND SHOULD NOT BE USED WITHOUT WRITTEN PERMISSION								

ROWS: 6

DIM R: (REF)		5.0 MM	6.0 MM	6.5 MM	7.5 MM	8.0 MM
DIM H:		5.05/199	6.04/238	6.66/258	7.54/297	8.05/317
POSITION	DIM M	MATERIAL NO	MATERIAL NO	MATERIAL NO	MATERIAL NO	MATERIAL NO
10	19.86/0.782	45971-1167	45971-1267	45971-1367	45971-1467	45971-1567
20	32.56/1.282	45971-2167	45971-2267	45971-2367	45971-2467	45971-2567
30	45.26/1.782	45971-3167	45971-3267	45971-3367	45971-3467	45971-3567
40	57.96/2.282	45971-4167	45971-4267	45971-4367	45971-4467	45971-4567
50	70.68/2.782	45971-5167	45971-5267	45971-5367	45971-5467	45971-5567
15	26.21/1.032	45971-6167	45971-6267	45971-6367	45971-6467	45971-6567
25	38.91/1.532	45971-7167	45971-7267	45971-7367	45971-7467	45971-7567
35	51.61/2.032	45971-8167	45971-8267	45971-8367	45971-8467	45971-8567
45	64.31/2.532	45971-9167	45971-9267	45971-9367	45971-9467	45971-9567

ROWS: 10

DIM R: (REF)		5.0 MM	6.0 MM	6.5 MM	7.5 MM	8.0 MM
DIM H:		5.05/199	6.04/238	6.66/258	7.54/297	8.05/317
POSITION	DIM M	MATERIAL NO	MATERIAL NO	MATERIAL NO	MATERIAL NO	MATERIAL NO
10	19.86/0.782	45971-1117	45971-1217	45971-1317	45971-1417	45971-1517
20	32.56/1.282	45971-2117	45971-2217	45971-2317	45971-2417	45971-2517
30	45.26/1.782	45971-3117	45971-3217	45971-3317	45971-3417	45971-3517
40	57.96/2.282	45971-4117	45971-4217	45971-4317	45971-4417	45971-4517
50	70.68/2.782	45971-5117	45971-5217	45971-5317	45971-5417	45971-5517
15	26.21/1.032	45971-6117	45971-6217	45971-6317	45971-6417	45971-6517
25	38.91/1.532	45971-7117	45971-7217	45971-7317	45971-7417	45971-7517
35	51.61/2.032	45971-8117	45971-8217	45971-8317	45971-8417	45971-8517
45	64.31/2.532	45971-9117	45971-9217	45971-9317	45971-9417	45971-9517

ROWS: 8

DIM R: (REF)		5.0 MM	6.0 MM	6.5 MM	7.5 MM	8.0 MM
DIM H:		5.05/199	6.04/238	6.66/258	7.54/297	8.05/317
POSITION	DIM M	MATERIAL NO	MATERIAL NO	MATERIAL NO	MATERIAL NO	MATERIAL NO
10	19.86/0.782	45971-1187	45971-1287	45971-1387	45971-1487	45971-1587
20	32.56/1.282	45971-2187	45971-2287	45971-2387	45971-2487	45971-2587
30	45.26/1.782	45971-3187	45971-3287	45971-3387	45971-3487	45971-3587
40	57.96/2.282	45971-4187	45971-4287	45971-4387	45971-4487	45971-4587
50	70.68/2.782	45971-5187	45971-5287	45971-5387	45971-5487	45971-5587
15	26.21/1.032	45971-6187	45971-6287	45971-6387	45971-6487	45971-6587
25	38.91/1.532	45971-7187	45971-7287	45971-7387	45971-7487	45971-7587
35	51.61/2.032	45971-8187	45971-8287	45971-8387	45971-8487	45971-8587
45	64.31/2.532	45971-9187	45971-9287	45971-9387	45971-9487	45971-9587

MATED STACK HEIGHTS
GIVEN IN MILLIMETERS (MM) FOR REFERENCE ONLY

<p style="text-align: center;">SEE SHEET 1</p> <p style="font-size: 8px;">EC NO: UCP2015-1206 DRAWN BY: RWHIPPLE 2014/10/23 CHKD: DMORGAN 2014/10/23 APPR: SMILLER 2015/01/05</p>	<p style="text-align: center;">QUALITY SYMBOLS</p> <p style="font-size: 10px;">▽ F/0</p> <p style="font-size: 10px;">▽ E/0</p> <p style="font-size: 10px;">▽ E/0</p>	<p style="font-size: 8px;">GENERAL TOLERANCES (UNLESS SPECIFIED)</p> <table border="1" style="width: 100%; border-collapse: collapse;"> <tr> <th></th> <th>mm</th> <th>INCH</th> </tr> <tr> <td>4 PLACES</td> <td>± ---</td> <td>± ---</td> </tr> <tr> <td>3 PLACES</td> <td>± ---</td> <td>± .010</td> </tr> <tr> <td>2 PLACES</td> <td>± 0.25</td> <td>± .015</td> </tr> <tr> <td>1 PLACE</td> <td>± 0.38</td> <td>± ---</td> </tr> <tr> <td>0 PLACE</td> <td>±</td> <td>±</td> </tr> </table>		mm	INCH	4 PLACES	± ---	± ---	3 PLACES	± ---	± .010	2 PLACES	± 0.25	± .015	1 PLACE	± 0.38	± ---	0 PLACE	±	±	<p style="font-size: 8px;">DIMENSION STYLE</p> <p style="text-align: center;">MM/IN</p>	<p style="font-size: 8px;">SCALE</p> <p style="text-align: center;">1:1</p>	<p style="font-size: 8px;">DESIGN UNITS</p> <p style="text-align: center;">INCH</p>	<p style="font-size: 8px;">THIRD ANGLE PROJECTION</p>	<p style="text-align: center; font-weight: bold; font-size: 12px;">SEARAY RECEPTACLE ASSEMBLY, TIN/LEAD 1.27/.050 CENTERS</p>
				mm	INCH																				
			4 PLACES	± ---	± ---																				
			3 PLACES	± ---	± .010																				
2 PLACES	± 0.25	± .015																							
1 PLACE	± 0.38	± ---																							
0 PLACE	±	±																							
DRAWN BY	DATE	<p style="font-size: 24px; font-weight: bold;">molex</p>																							
CHECKED BY	DATE																								
APPROVED BY	DATE																								
MATERIAL NO.			DOCUMENT NO.	SHEET NO.																					
ANGULAR ± --- °		DRAFT WHERE APPLICABLE MUST REMAIN WITHIN DIMENSIONS		SEE TABLES		RSD-45971-001		4 OF 4																	
THIS DRAWING CONTAINS INFORMATION THAT IS PROPRIETARY TO MOLEX INCORPORATED AND SHOULD NOT BE USED WITHOUT WRITTEN PERMISSION																									

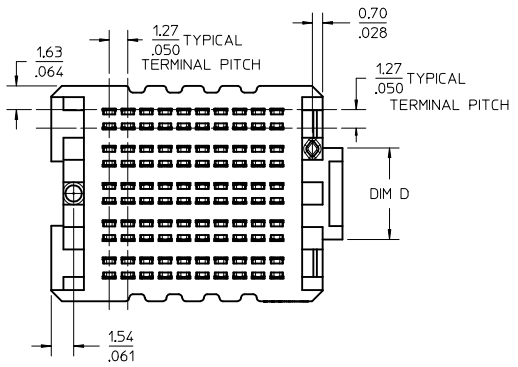

10 ROW
10 POSITION
SHOWN

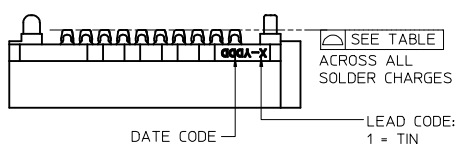

NOTE: THESE CODES MAY BE LOCATED ON EITHER SIDE OF THE HOUSING

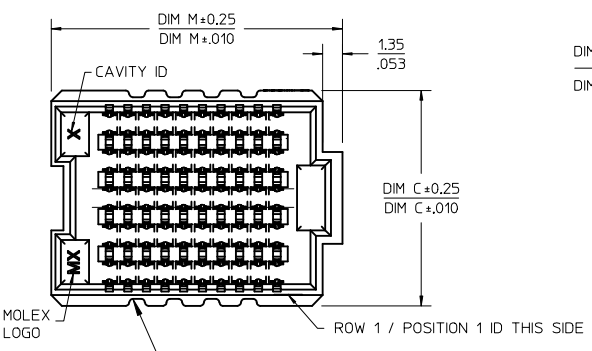

SEE SHEET 3 FOR
6 ROW GEOMETRY

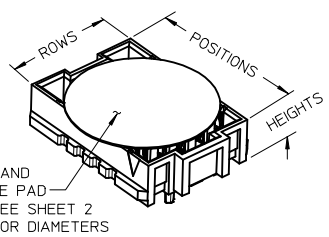
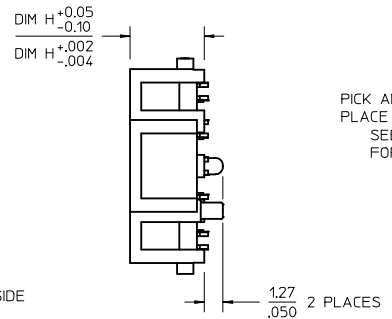

NOTES:

- MATERIALS: HOUSING: GLASS FILLED LCP (LIQUID CRYSTAL POLYMER), UL94V-0, BLACK
CONTACTS: COPPER ALLOY
SOLDER CHARGE: 95% TIN, 3.8% SILVER, 0.7% COPPER
- FINISH: SELECT GOLD IN CONTACT AREA: 30 MICROINCH MINIMUM
SELECT TIN IN TAIL, 50 MICROINCH MINIMUM
OVERALL NICKEL UNDERPLATE
- PRODUCT SPECIFICATION: PS-45970-001
- PACKAGING SPECIFICATION: PK-45971-002 (TAPE AND REEL)
- MATES WITH SEARAY PLUG ASSEMBLY SERIES 45970
- APPLICATION SPECIFICATION: AS-45970-001
- COSMETIC SPECIFICATION: PS-45499-002 CLASS B
- PART STATUS: CONTACT MOLEX

POSITIONS	TOTAL NUMBER OF EDGE NOTCHES	
10	8	0.15/.006
15	14	
20	18	
25	24	
30	28	
35	34	0.23/.009
40	38	
45	44	
50	48	

CLARIFY OVERALL LENGTH EC NO: UCP2015-5493 DRWNS:VANG01 2015/06/15 CHKD:TIBARRA 2015/08/04 APPR:SMILLER 2015/08/07	QUALITY SYMBOLS ▽=0 ▽=0 ▽=0	GENERAL TOLERANCES (UNLESS SPECIFIED) mm INCH 4 PLACES ± --- ± --- 3 PLACES ± --- ± .010 2 PLACES ± 0.25 ± .015 1 PLACE ± 0.38 ± --- 0 PLACE ± ±	DIMENSION STYLE MM/IN DRAWN BY DATE TGREGORI 2005/05/17 CHECKED BY DATE JCOMERCI 2005/05/17 APPROVED BY DATE JCOMERCI 2010/03/05	SCALE 3:1 DESIGN UNITS INCH THIRD ANGLE PROJECTION	TITLE SEARAY RECEPTACLE ASSEMBLY 1.27/.050 CENTERS molex	MATERIAL NO. SEE TABLES SHT 4 SIZE B	DOCUMENT NO. SD-45971-001	SHEET NO. 1 OF 4
	DRAFT WHERE APPLICABLE MUST REMAIN WITHIN DIMENSIONS		ANGULAR ± --- °		THIS DRAWING CONTAINS INFORMATION THAT IS PROPRIETARY TO MOLEX INCORPORATED AND SHOULD NOT BE USED WITHOUT WRITTEN PERMISSION			

10 ROW
10 POSITION
SHOWN

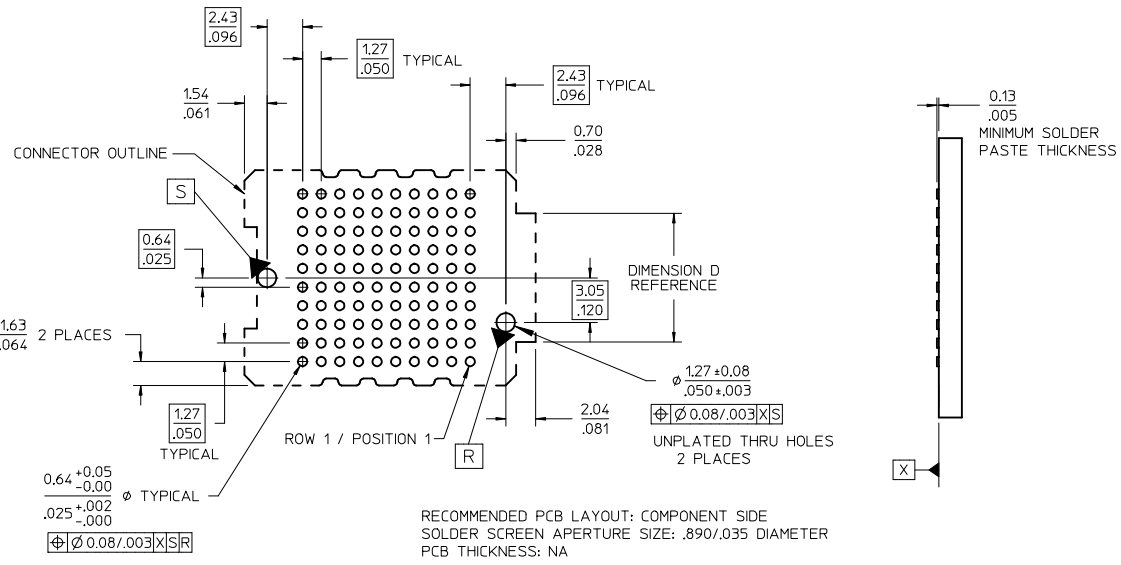

NUMBER OF ROWS	DIMENSION D
6	SEE SHEET 3
8	3.70/.146
10	6.24/.246

RECOMMENDED PCB LAYOUT: COMPONENT SIDE
SOLDER SCREEN APERTURE SIZE: .890/.035 DIAMETER
PCB THICKNESS: NA

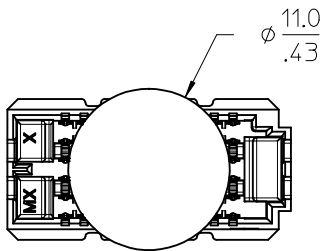

6 ROW OPTION

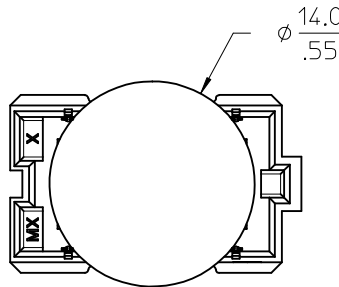

8 ROW OPTION

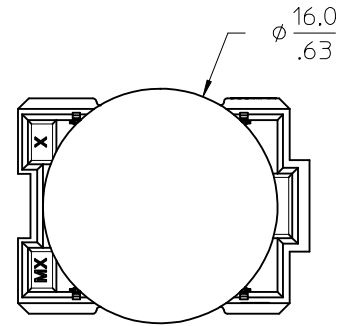

10 ROW OPTION

PICK AND PLACE
PAD DIAMETERS
10 POSITION VERSIONS SHOWN

SEE SHEET 1 EC NO: UCP2015-5493 DRWN: SVANG01 2015/06/25 CHKD: TIBARRA 2015/08/04 APPR: SMILLER 2015/08/07	QUALITY SYMBOLS	GENERAL TOLERANCES (UNLESS SPECIFIED) mm INCH 4 PLACES ± --- ± --- 3 PLACES ± --- ± .010 2 PLACES ± 0.25 ± .015 1 PLACE ± 0.38 ± --- 0 PLACE ± ± ANGULAR ± --- ° DRAFT WHERE APPLICABLE MUST REMAIN WITHIN DIMENSIONS	DIMENSION STYLE MM/IN	SCALE 3:1	DESIGN UNITS INCH	THIRD ANGLE PROJECTION	
	REV X		DRAWN BY TGREGORI	DATE 2005/05/17	TITLE SEARAY RECEPTACLE ASSEMBLY 1.27/.050 CENTERS		
			CHECKED BY JCOMERC I	DATE 2005/05/17	molex DOCUMENT NO. SD-45971-001 SHEET NO. 2 OF 4		
			APPROVED BY JCOMERC I	DATE 2010/03/05			

10 9 8 7 6 5 4 3 2 1

6 ROW
10 POSITION

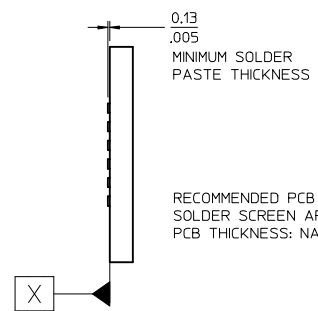
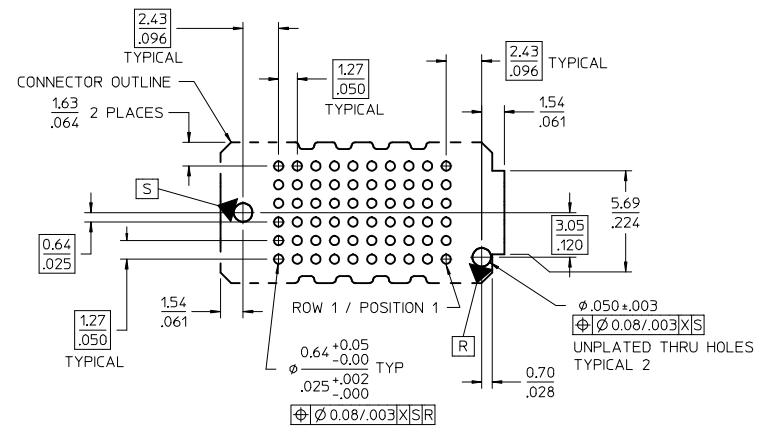

RECOMMENDED PCB LAYOUT: COMPONENT SIDE
SOLDER SCREEN APERTURE SIZE: .089/.035 DIAMETER
PCB THICKNESS: NA

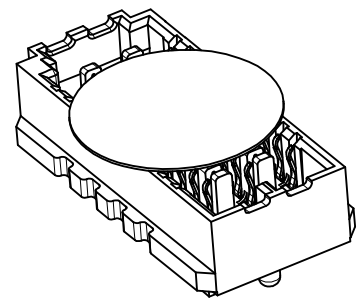
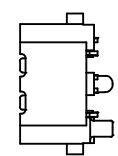
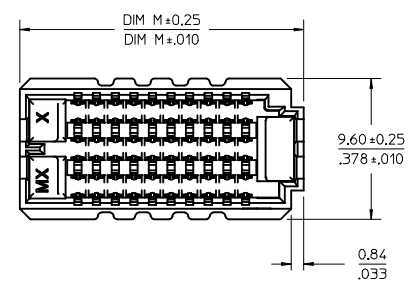

6 ROW
10 POSITION
SHOWN

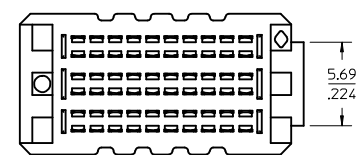
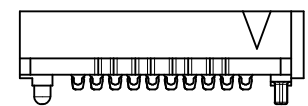

SEE SHEET 1 EC NO: UCP2015-5493 DRWN: SWANG01 2015/06/25 CHKD: TIBARRA 2015/08/04 APPR: SMILLER 2015/08/07 X	DESCRIPTION REV	QUALITY SYMBOLS	GENERAL TOLERANCES (UNLESS SPECIFIED)		DIMENSION STYLE		SCALE	DESIGN UNITS	THIRD ANGLE PROJECTION			
		$\nabla = 0$ $\nabla = 0$ $\nabla = 0$	mm	INCH	MM/IN	3:1	INCH	TITLE SEARAY RECEPTACLE ASSEMBLY 1.27/.050 CENTERS molex DOCUMENT NO. SD-45971-001 SHEET NO. 3 OF 4				
		4 PLACES ± --- ± --- 3 PLACES ± --- ± .010 2 PLACES ± 0.25 ± .015 1 PLACE ± 0.38 ± --- 0 PLACE ± ±	ANGULAR ± --- °		DRAWN BY	DATE						
			DRAFT WHERE APPLICABLE MUST REMAIN WITHIN DIMENSIONS		TGREGORI	2005/05/17						
			SEE TABLES SHT 4	JCMERC I	2005/05/17							
				JCMERC I	2010/03/05							

9 8 7 6 5 4 3 2 1

ROWS: 6 DIMENSION C = 9.60/.378 DIMENSION D = 5.69/.224

DIM R: (REF)		5.0 MM	6.0 MM	6.5 MM	7.5 MM	8.0 MM
DIM H:		5.05/.199	6.04/.238	6.66/.258	7.54/.297	8.05/.317
POSITION	DIM M	MATERIAL NO	MATERIAL NO	MATERIAL NO	MATERIAL NO	MATERIAL NO
10	19.35/0.762	45971-1165	45971-1265	45971-1365	45971-1465	45971-1565
20	32.05/1.262	45971-2165	45971-2265	45971-2365	45971-2465	45971-2565
30	44.75/1.762	45971-3165	45971-3265	45971-3365	45971-3465	45971-3565
40	57.45/2.262	45971-4165	45971-4265	45971-4365	45971-4465	45971-4565
50	70.15/2.762	45971-5165	45971-5265	45971-5365	45971-5465	45971-5565
15	25.70/1.012	45971-6165	45971-6265	45971-6365	45971-6465	45971-6565
25	38.40/1.512	45971-7165	45971-7265	45971-7365	45971-7465	45971-7565
35	51.10/2.012	45971-8165	45971-8265	45971-8365	45971-8465	45971-8565
45	63.80/2.512	45971-9165	45971-9265	45971-9365	45971-9465	45971-9565

ROWS: 10 DIMENSION C = 14.68/.578 DIMENSION D = 6.24/.246

DIM R: (REF)		5.0 MM	6.0 MM	6.5 MM	7.5 MM	8.0 MM
DIM H:		5.05/.199	6.04/.238	6.66/.258	7.54/.297	8.05/.317
POSITION	DIM M	MATERIAL NO	MATERIAL NO	MATERIAL NO	MATERIAL NO	MATERIAL NO
10	19.88/0.784	45971-1115	45971-1215	45971-1315	45971-1415	45971-1515
20	32.58/1.284	45971-2115	45971-2215	45971-2315	45971-2415	45971-2515
30	45.28/1.784	45971-3115	45971-3215	45971-3315	45971-3415	45971-3515
40	57.98/2.284	45971-4115	45971-4215	45971-4315	45971-4415	45971-4515
50	70.68/2.784	45971-5115	45971-5215	45971-5315	45971-5415	45971-5515
15	26.23/1.034	45971-6115	45971-6215	45971-6315	45971-6415	45971-6515
25	38.93/1.534	45971-7115	45971-7215	45971-7315	45971-7415	45971-7515
35	51.63/2.034	45971-8115	45971-8215	45971-8315	45971-8415	45971-8515
45	64.33/2.534	45971-9115	45971-9215	45971-9315	45971-9415	45971-9515

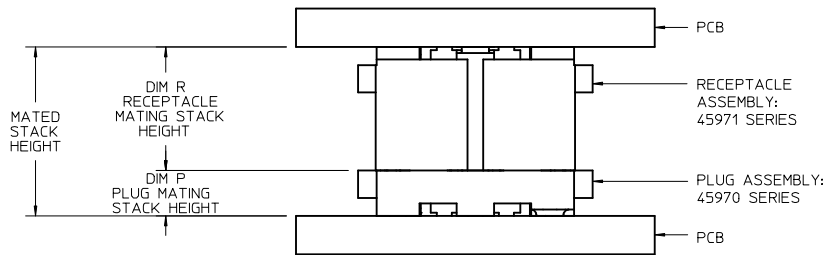

STACK HEIGHTS GIVEN IN MILLIMETERS (MM) FOR REFERENCE ONLY

ROWS: 8 DIMENSION C = 12.14/.478 DIMENSION D = 3.70/.146

DIM R: (REF)		5.0 MM	6.0 MM	6.5 MM	7.5 MM	8.0 MM
DIM H:		5.05/.199	6.04/.238	6.66/.258	7.54/.297	8.05/.317
POSITION	DIM M	MATERIAL NO	MATERIAL NO	MATERIAL NO	MATERIAL NO	MATERIAL NO
10	19.88/0.784	45971-1185	45971-1285	45971-1385	45971-1485	45971-1585
20	32.58/1.284	45971-2185	45971-2285	45971-2385	45971-2485	45971-2585
30	45.28/1.784	45971-3185	45971-3285	45971-3385	45971-3485	45971-3585
40	57.98/2.284	45971-4185	45971-4285	45971-4385	45971-4485	45971-4585
50	70.68/2.784	45971-5185	45971-5285	45971-5385	45971-5485	45971-5585
15	26.23/1.034	45971-6185	45971-6285	45971-6385	45971-6485	45971-6585
25	38.93/1.534	45971-7185	45971-7285	45971-7385	45971-7485	45971-7585
35	51.63/2.034	45971-8185	45971-8285	45971-8385	45971-8485	45971-8585
45	64.33/2.534	45971-9185	45971-9285	45971-9385	45971-9485	45971-9585

MATING STACK HEIGHTS (DIMENSION R) GIVEN IN MILLIMETERS (MM) FOR REFERENCE ONLY

DIM P PLUG STACK HEIGHT	DIM R RECEPTACLE STACK HEIGHT					
	MM	5.0	6.0	6.5	7.5	8.0
2.0	7.0	8.0	8.5	9.5	10.0	
3.0	8.0	9.0	9.5	10.5	11.0	
3.5	8.5	9.5	10.0	11.0	11.5	
2.5	7.5	8.5	9.0	10.0	10.5	
4.5	9.5	10.5	11.0	12.0	12.5	
5.0	10.0	11.0	11.5	12.5	13.0	
7.0	12.0	13.0	13.5	14.5	15.0	

MATED STACK HEIGHTS GIVEN IN MILLIMETERS (MM) FOR REFERENCE ONLY

SEE SHEET 1 EC NO: UCP2015-5493 DRW: SVANG01 2015/06/25 CHKD: TIBARRA 2015/08/04 APPR: SMILLER 2015/08/07	QUALITY SYMBOLS ∇=0 ∇=0 ∇=0	GENERAL TOLERANCES (UNLESS SPECIFIED)		DIMENSION STYLE		SCALE	DESIGN UNITS	THIRD ANGLE PROJECTION
				MM/IN		1:1	INCH	
				DRAWN BY DATE		TITLE		
				CHECKED BY DATE		SD-45971-001		
		APPROVED BY DATE		MATERIAL NO.		DOCUMENT NO.		SHEET NO.
		ANGULAR ±---°		SEE TABLES		SD-45971-001		4 OF 4
		DRAFT WHERE APPLICABLE MUST REMAIN WITHIN DIMENSIONS		THIS DRAWING CONTAINS INFORMATION THAT IS PROPRIETARY TO MOLEX INCORPORATED AND SHOULD NOT BE USED WITHOUT WRITTEN PERMISSION				