



Chipsmall Limited consists of a professional team with an average of over 10 year of expertise in the distribution of electronic components. Based in Hongkong, we have already established firm and mutual-benefit business relationships with customers from,Europe,America and south Asia,supplying obsolete and hard-to-find components to meet their specific needs.

With the principle of “Quality Parts,Customers Priority,Honest Operation,and Considerate Service”,our business mainly focus on the distribution of electronic components. Line cards we deal with include Microchip,ALPS,ROHM,Xilinx,Pulse,ON,Everlight and Freescale. Main products comprise IC,Modules,Potentiometer,IC Socket,Relay,Connector.Our parts cover such applications as commercial,industrial, and automotives areas.

We are looking forward to setting up business relationship with you and hope to provide you with the best service and solution. Let us make a better world for our industry!



## Contact us

Tel: +86-755-8981 8866 Fax: +86-755-8427 6832

Email & Skype: info@chipsmall.com Web: www.chipsmall.com

Address: A1208, Overseas Decoration Building, #122 Zhenhua RD., Futian, Shenzhen, China



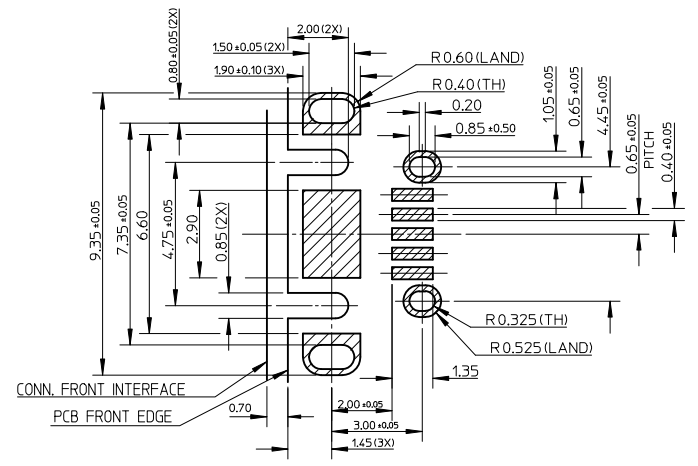
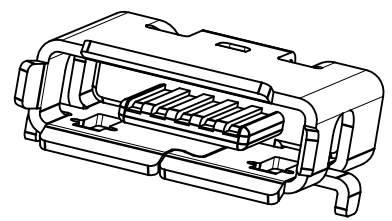
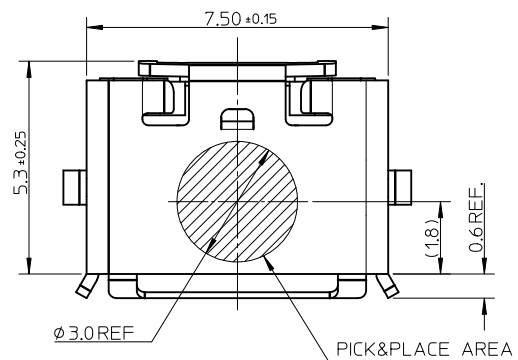

RECOMMENDED P.C.B. PATTERN LAYOUT

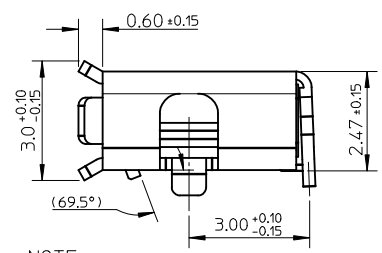
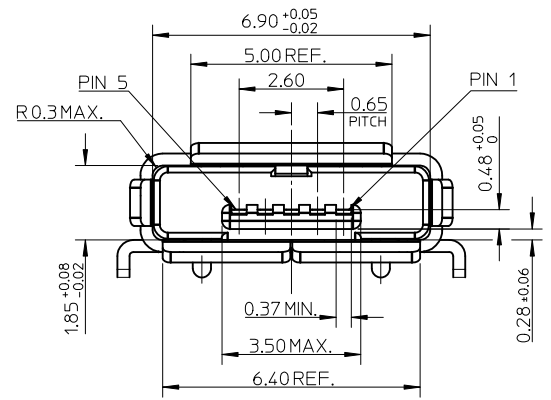

NOTE :

- MATERIAL :  
HOUSING : LCP, BLACK, UL94V-0  
TERMINAL : COPPER ALLOY THICKNESS = 0.15 MM  
SHIELD CASE : STAINLESS STEEL THICKNESS = 0.30 MM
- PLATING :  
TERMINAL: CONTACT AREA : GOLD FLASH (0.11 MICRON MIN.) OVER MINIMUM 0.75 MICRON Pd/Ni.  
SOLDER TAIL AREA : GOLD FLASH (0.05 MICRON MIN.).  
UNDER PLATING : NICKEL 2.0 MICROMN MINIMUM.  
SHIELD : MATTE TIN 1.27 MICRON MINIMUM.  
UNDER PLATING : NICKEL 1.27 MICRON MINIMUM.
- TAIL COPLANARITY 0.08 MM MAXIMUM.
- COMPLIANT TO RoHS DIRECTIVE 2002/95/EC AND ELV IDRECTIVE 2000/53/EC.

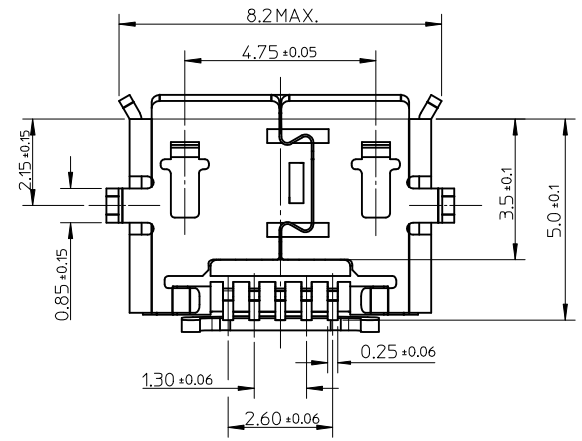
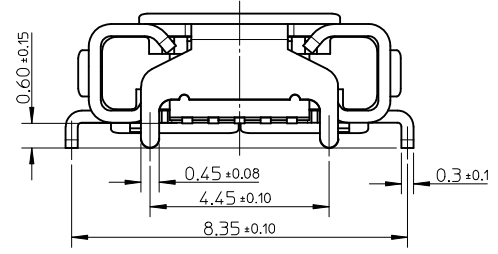

REVISE EC NO: SH2011-0342 DRWN: XJSONG CHKD: APPR: RZHANG	2011/05/16 2011/09/05	QUALITY SYMBOLS F <sub>A</sub> = 0 F <sub>C</sub> = 0 F <sub>P</sub> = 0	GENERAL TOLERANCES (UNLESS SPECIFIED)		DIMENSION STYLE MM ONLY		SCALE 1:1	DESIGN UNITS METRIC	THIRD ANGLE PROJECTION		
			mm	INCH	DRAWN BY XJSONG	DATE 2007/03/15	TITLE MICRO USB AB REC. TOP MOUNT ASS'Y				
			4 PLACES ± ---	± ---	CHECKED BY JTIAN	DATE 2007/03/15	MOLEX INCORPORATED				
			3 PLACES ± ---	± ---	APPROVED BY JNCHEN	DATE 2007/03/15	DOCUMENT NO. SD-47590-001				
B2	REV		DRAFT WHERE APPLICABLE MUST REMAIN WITHIN DIMENSIONS		SIZE A3	THIS DRAWING CONTAINS INFORMATION THAT IS PROPRIETARY TO MOLEX INCORPORATED AND SHOULD NOT BE USED WITHOUT WRITTEN PERMISSION					
					MATERIAL NO. 47590-0001		SHEET NO. 1 OF 1				