



Chipsmall Limited consists of a professional team with an average of over 10 year of expertise in the distribution of electronic components. Based in Hongkong, we have already established firm and mutual-benefit business relationships with customers from,Europe,America and south Asia,supplying obsolete and hard-to-find components to meet their specific needs.

With the principle of “Quality Parts,Customers Priority,Honest Operation,and Considerate Service”,our business mainly focus on the distribution of electronic components. Line cards we deal with include Microchip,ALPS,ROHM,Xilinx,Pulse,ON,Everlight and Freescale. Main products comprise IC,Modules,Potentiometer,IC Socket,Relay,Connector.Our parts cover such applications as commercial,industrial, and automotives areas.

We are looking forward to setting up business relationship with you and hope to provide you with the best service and solution. Let us make a better world for our industry!



Contact us

Tel: +86-755-8981 8866 Fax: +86-755-8427 6832

Email & Skype: info@chipsmall.com Web: www.chipsmall.com

Address: A1208, Overseas Decoration Building, #122 Zhenhua RD., Futian, Shenzhen, China



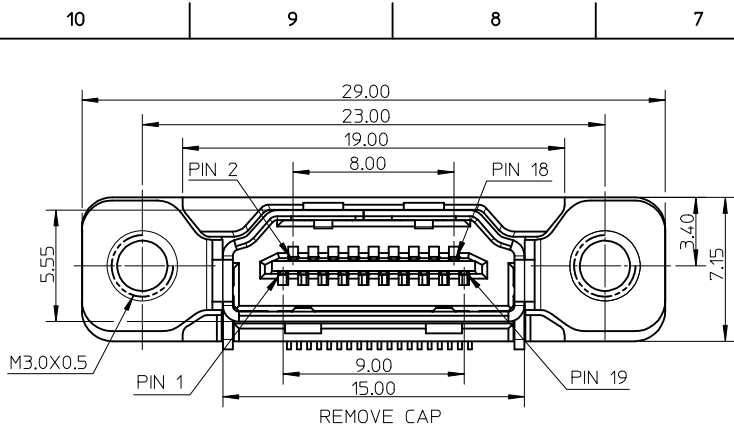

NOTES:

1. MATERIAL:
HOUSING/COVER: HIGH TEMPERATURE THERMAL PLASTIC UL 94V-0. COLOR: BLACK.
SHELL: COPPER ALLOY.
TERMINAL: COPPER ALLOY.
2. PLATING:
TERMINAL:
CONTACT AREA: PLATING SPEC REFER TO REMARK IN CHART.
SOLDER AREA: 1 MICROMETER MIN. TIN-BISMUTH ALLOY PLATED.
UNDER PLATE: 1.27 MICROMETER MIN. NICKEL.
SHELL: 3 MICROMETER MIN. MATTE TIN PLATE OVERALL.
3. COPLANARITY: 0.10mm MAX .
4. PRODUCT SPECIFICATION REFER TO PS-47632-001.
5. PACKAGE SPECIFICATION REFER TO PK-47632-002.
6. PRODUCT COMPLIANT TO RoHS DIRECTIVE 2002/95/EC AND ELV DIRECTIVE 2000/53/EC.

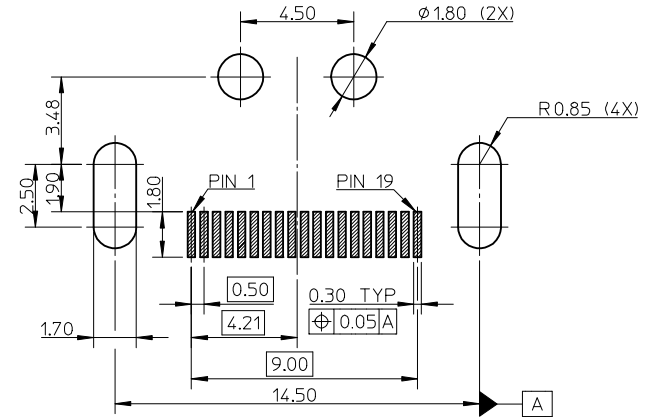
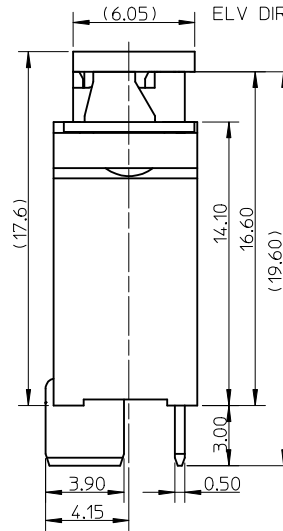
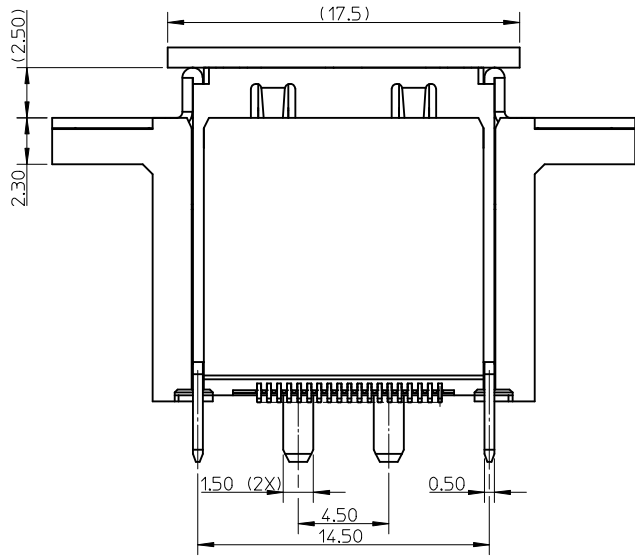
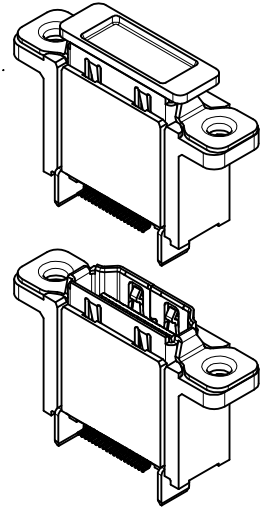

RECOMMENDED PCB LAYOUT
CONNECTOR SIDE
THICKNESS=1.60mm
(GENERAL TOLERANCE: ±0.05)

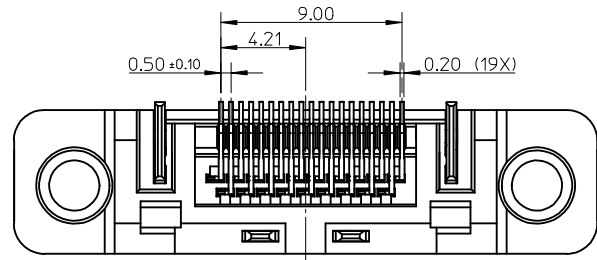

P/N	CONTACT PLATING SPEC
47632-2000	GOLD 0.38 MICROMETER MIN.
47632-2100	GOLD FLASH

D2	F3-Add UL grade to complete material info.	25.Jun.2013
D1	A8-Gold plating thk 0.3u update to 0.38u (typo error)	28.Jan.2013
REV NO	DESCRIPTION	DATE

REV	DESCRIPTION
D2	

QUALITY SYMBOLS	
	=0
	=0.15

GENERAL TOLERANCES (UNLESS SPECIFIED)	
4 PLACES	± 0.15
3 PLACES	± 0.25
2 PLACES	± 0.30
1 PLACE	± 0.40
ANGULAR ± 1°	

DIMENSION STYLE	SCALE	DESIGN UNITS	THIRD ANGLE PROJECTION
MM ONLY	4:1	METRIC	
DRAWN BY	DATE	TITLE	
CHEN BO	2007/10/18	HDMI RECEPTACLE VERTICAL SMT TYPE WITH FLANGE	
CHECKED BY	DATE	MATERIAL NO.	
JOHNSON	2007/10/18	SEE CHART	
APPROVED BY	DATE	DOCUMENT NO.	
HARVEY	2007/10/18	SD-47632-200	
MATERIAL NO.		SHEET NO.	
SEE CHART		1 OF 1	