



Chipsmall Limited consists of a professional team with an average of over 10 year of expertise in the distribution of electronic components. Based in Hongkong, we have already established firm and mutual-benefit business relationships with customers from,Europe,America and south Asia,supplying obsolete and hard-to-find components to meet their specific needs.

With the principle of "Quality Parts,Customers Priority,Honest Operation,and Considerate Service",our business mainly focus on the distribution of electronic components. Line cards we deal with include Microchip,ALPS,ROHM,Xilinx,Pulse,ON,Everlight and Freescale. Main products comprise IC,Modules,Potentiometer,IC Socket,Relay,Connector.Our parts cover such applications as commercial,industrial, and automotives areas.

We are looking forward to setting up business relationship with you and hope to provide you with the best service and solution. Let us make a better world for our industry!



## Contact us

Tel: +86-755-8981 8866 Fax: +86-755-8427 6832

Email & Skype: info@chipsmall.com Web: www.chipsmall.com

Address: A1208, Overseas Decoration Building, #122 Zhenhua RD., Futian, Shenzhen, China



# HBA 9405W Series x16 PCIe Tri-Mode Storage Adapters

## 12Gb/s SAS/SATA/PCIe (NVMe) Tri-Mode HBAs

### Industry's First Single-Chip, x16 Low-Profile HBAs with Tri-Mode SerDes Technology

Broadcom enables high performance storage connectivity and flexible system designs that support any combination of SAS, SATA, and PCIe (NVMe)\* devices with the industry's first x16 HBA series with Tri-Mode SerDes technology. The x16 PCIe Gen3 Tri-Mode HBA series delivers high-performance storage for bandwidth-intense applications such as big data analytics, media applications and applications performing large sequential reads.

### High-Performance to Big Data Applications

The x16 Tri-Mode HBAs with 16 internal or external ports bring performance benefits to the storage tier by providing connectivity and data protection to large-scale storage enclosures computing big data applications such as analytics and business intelligence. Based on the single-core SAS3616W Tri-Mode I/O controller (IOC), the HBAs provide a bandwidth and IOPS performance increase compared to previous generations.

### Endless Design Flexibility using Tri-Mode Controllers

Broadcom Tri-Mode SerDes Technology enables the operation of NVMe, SAS, or SATA storage devices in a single drive bay. A single controller can operate in all three modes concurrently and negotiate between the speeds and protocols to seamlessly work with any of the three types of storage devices. Tri-Mode support provides a non-disruptive way to evolve existing data center infrastructure. By upgrading to a Tri-Mode HBA, users can expand beyond SAS/SATA and use NVMe without major changes to other system configurations. Take advantage of x16 slots and optimize two x8 controllers into one card; delivering more versatility and optimal slot performance density.

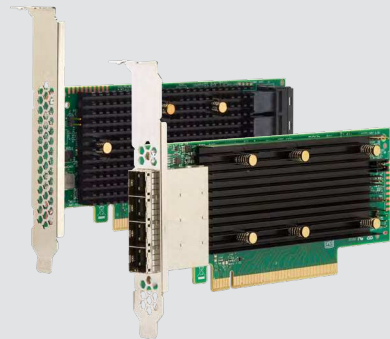

### Applications

- Ideal for bandwidth-intense applications such as UHD and big data analytics
- Tri-Mode connectivity enabling maximum data center flexibility
- Highest sequential throughput; ideal for video streaming, big data analytics, medical imaging and media applications
- High bandwidth storage to SAS, SATA, or NVMe devices

### Key Features

- x16 PCIe 3.1 Host Interface
  - Supports x16, x8, x4, x2, x1 PCIe lanes at a transfer rate up to 8.0 GT/s per lane, full duplex
  - Lane and polarity reversal
  - Variable PCIe bandwidth negotiation
- Low Profile MD2 Form Factor
- Tri-Mode enabled external storage interface
- Supports 12Gb/s SAS, 6Gb/s SATA, and PCIe (NVMe)\* up to 8.0 GT/s

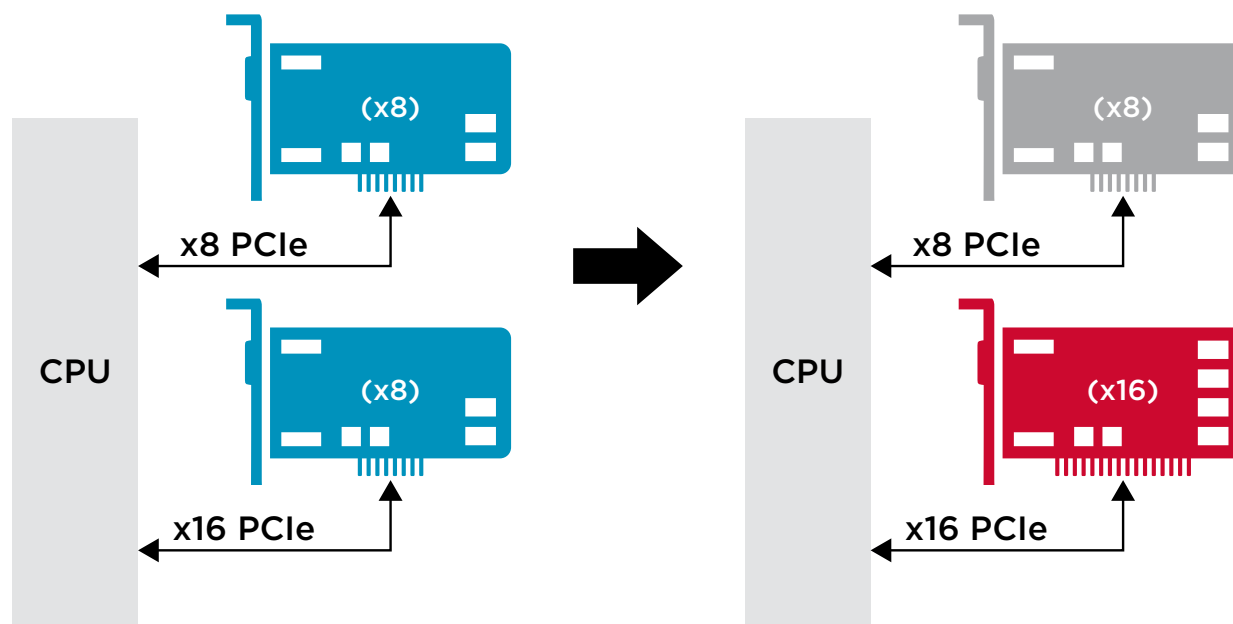

## 9405W Tri-Mode HBAs

	9405W-16e	9405W-16i
Ports	16 external	16 internal
Connectors	Four (x4) SFF-8644	Four (x4) SFF-8643
Storage Interface Support	SAS, SATA, PCIe (NVMe)*	SAS, SATA, PCIe (NVMe)
Max Devices Per Controller	SAS/SATA: 1024, NVMe: 24*	SAS/SATA: 1024, NVMe: 24
I/O Processor / SAS Controller	SAS3616W	SAS3616W
Host Bus Type	PCIe 3.1 x16	PCIe 3.1 x16
Power	14.0W	14.0W
Physical Dimensions	6.600" x 2.712" (167.65 mm x 68.90 mm)	6.127" x 2.712" (155.65 mm x 68.90 mm)
Cable Support	Passive copper, active copper, active optical	Passive
Operating Conditions	Operating: 0°C to 55°C, 20 to 80% non-condensing Airflow: 200 LFM Storage: -45°C to 105°C, 5 to 90% non-condensing	Operating: 0°C to 55°C, 20 to 80% non-condensing Airflow: 200 LFM Storage: -45°C to 105°C, 5 to 90% non-condensing
MTBF (Calculated)	>4,500,000 hours at 40°C	>4,500,000 hours at 40°C
Operating Voltage	+12V +/--8%; 3.3V +/--9%	+12V +/--8%; 3.3V +/--9%
Hardware Warranty	3 years; with advanced replacement option	3 years; with advanced replacement option
Regulator Certifications	USA (FCC 47 CFR part 15 Subpart B, class B); Canada (ICES -003, Class B); Taiwan (CNS 13438); Japan (VCCI V-3); Australia/New Zealand (AS/NZS CISPR 22); Korea (RRA no 2013-24 & 25); Europe (EN55022/EN55024); Safety: EN/IEC/UL 60950; RoHS; WEEE	
OS Support	Microsoft Windows, Linux, VMware. Contact Oracle support for Oracle Solaris driver or software support. See <a href="http://www.broadcom.com/support/download-search">www.broadcom.com/support/download-search</a> for details on versions.	
<b>Ordering Information</b>		
Single Pack	05-50044-00	05-50047-00

\*9405W-16e designs connecting to external PCIe JBOF enclosures have unique design constraints. Contact your Broadcom sales representative or FAE before starting these designs.