



Chipsmall Limited consists of a professional team with an average of over 10 year of expertise in the distribution of electronic components. Based in Hongkong, we have already established firm and mutual-benefit business relationships with customers from,Europe,America and south Asia,supplying obsolete and hard-to-find components to meet their specific needs.

With the principle of “Quality Parts,Customers Priority,Honest Operation,and Considerate Service”,our business mainly focus on the distribution of electronic components. Line cards we deal with include Microchip,ALPS,ROHM,Xilinx,Pulse,ON,Everlight and Freescale. Main products comprise IC,Modules,Potentiometer,IC Socket,Relay,Connector.Our parts cover such applications as commercial,industrial, and automotives areas.

We are looking forward to setting up business relationship with you and hope to provide you with the best service and solution. Let us make a better world for our industry!



Contact us

Tel: +86-755-8981 8866 Fax: +86-755-8427 6832

Email & Skype: info@chipsmall.com Web: www.chipsmall.com

Address: A1208, Overseas Decoration Building, #122 Zhenhua RD., Futian, Shenzhen, China



SERPAC 052 (exploded isometric)

Electronic Enclosures

- Click on image to show toolbar. Use ▶ || to Play/Pause Animation.
- Left click and drag on image to move 3D model.

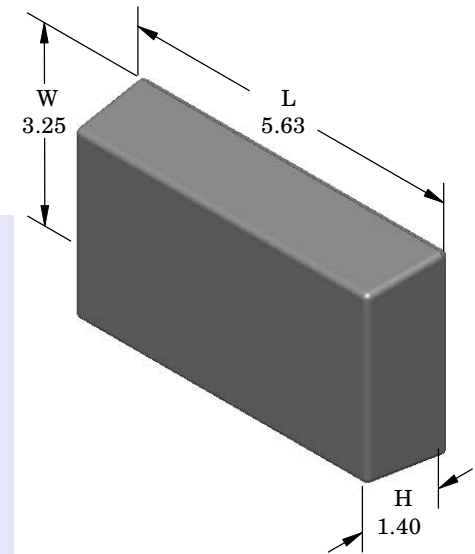
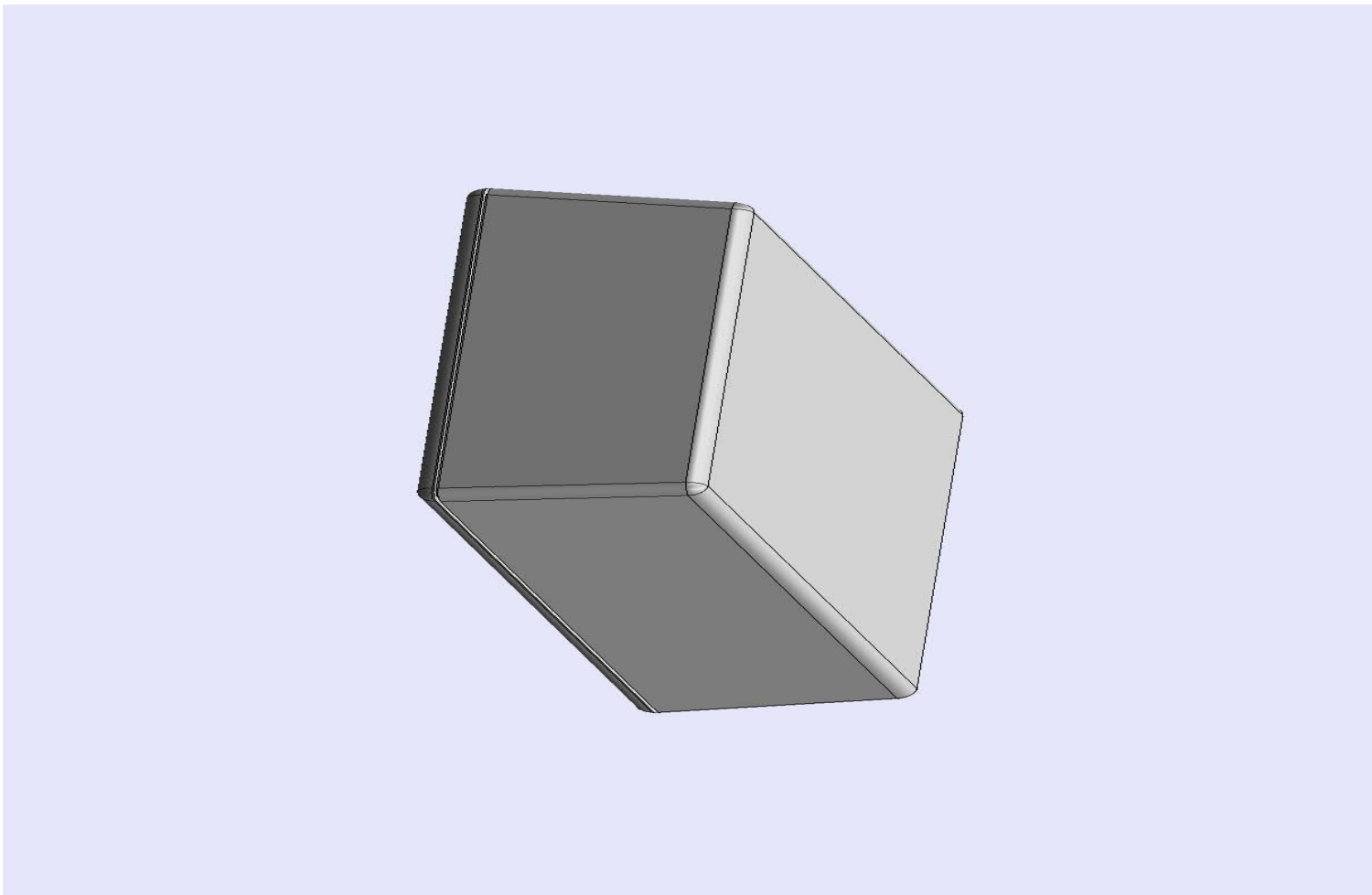

- a) Zoom in & out with center wheel.
- b) Pause at any moment to view and or print views.
- c) Change the views to ortho and section views if needed from the Views pull down menu.
- d) Explore options included in the tool bar like: Views, Transparency of model, Lighting type, etc.

PART NO.	DESCRIPTION (Included)	ACCESSORIES (Optional)	
5-2	TOP	PART NO.	DESCRIPTION
05	BOTTOM	51	Non-skid Feet
6005	#4X3/8" Self tapping (4)	350	Prototype grid board
		450	Prototype clad board

Notes: Enclosure weight .22 lbs / 101 gm

1) Enclosure meets or exceeds IP40 and NEMA 1

2) Circuit Board drawings can be download at:

<http://www.serpac.com/Accessories/CircuitBoard/drawings/350-450-cbg.pdf>

3) All components are RoHS Compliant.

ALL DIMENSIONS ARE ±.010" 3/17/10 (1 of 2)
619 Commercial Ave. Covina, CA 91723
Ph. (626) 331-0517 Ex. (626) 331-8584 serpac.com

SERPAC 052 (user print)

Electronic Enclosures

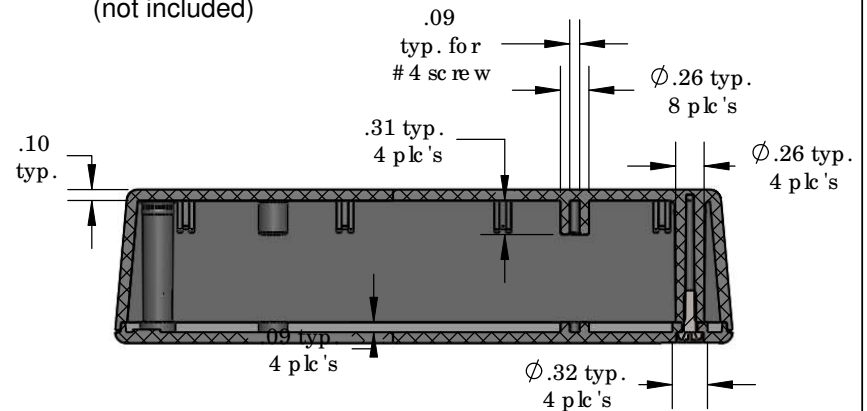
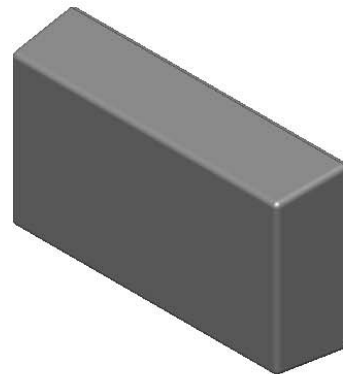
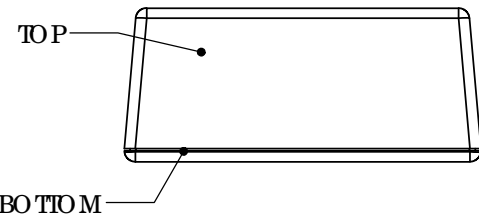
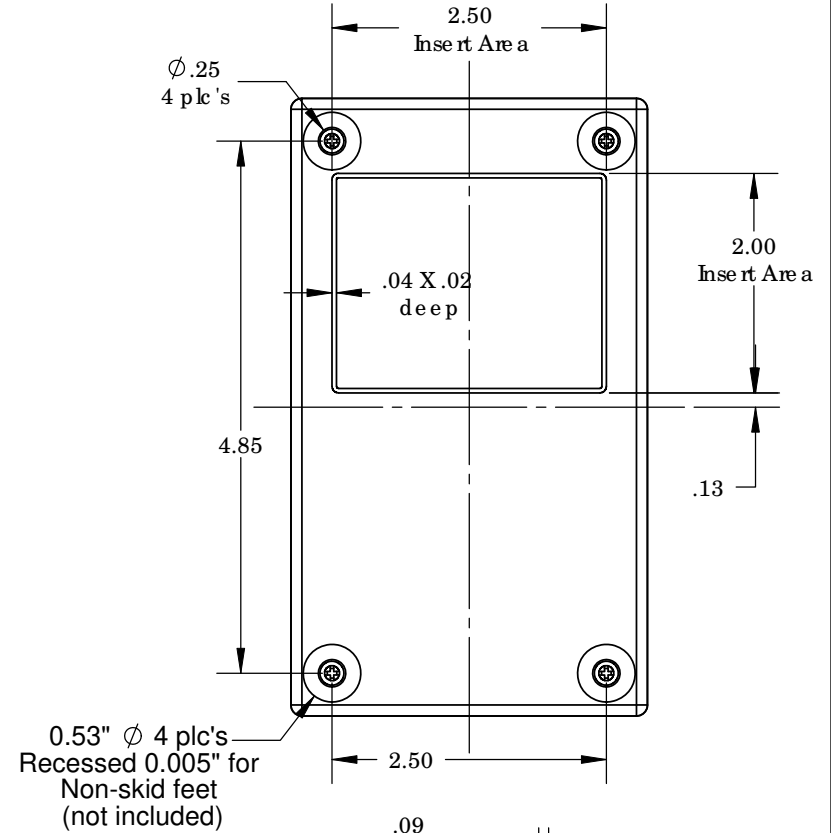
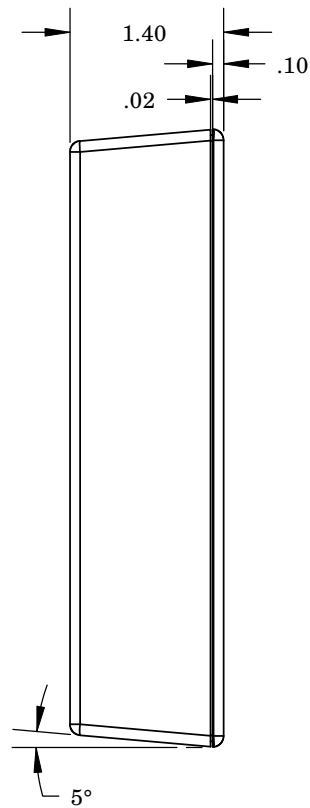
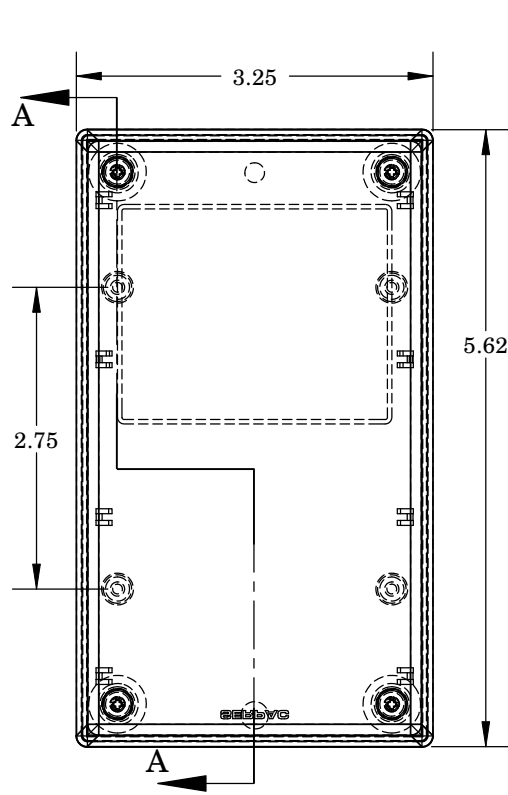

PART NO.	DESCRIPTION (Included)	ACCESSORIES (Optional)	
5-2	TOP	PART NO.	DESCRIPTION
05	BOTTOM	51	Non-skid Feet
6005	#4X3/8" self tapping (4)	350	Prototype grid board
		450	Prototype clad board

Notes: Enclosure weight .22 lbs / 101 gm
 1) Enclosure meets or exceeds IP40 and NEMA 1
 2) Circuit Board drawings can be downloaded at:

<http://www.serpac.com/Accessories/CircuitBoard/drawings/350-450-cbg.pdf>

3) All components are RoHS Compliant.

SECTION A-A
 SCALE 1 : 1.75

ALL DIMENSIONS ARE ± .010" 3/17/10 (2 of 2)
 619 Commercial Ave. Covina, CA 91723
 Ph. (626) 331-0517 Ex. (626) 331-8584 www.serpac.com