



Chipsmall Limited consists of a professional team with an average of over 10 year of expertise in the distribution of electronic components. Based in Hongkong, we have already established firm and mutual-benefit business relationships with customers from,Europe,America and south Asia,supplying obsolete and hard-to-find components to meet their specific needs.

With the principle of “Quality Parts,Customers Priority,Honest Operation,and Considerate Service”,our business mainly focus on the distribution of electronic components. Line cards we deal with include Microchip,ALPS,ROHM,Xilinx,Pulse,ON,Everlight and Freescale. Main products comprise IC,Modules,Potentiometer,IC Socket,Relay,Connector.Our parts cover such applications as commercial,industrial, and automotives areas.

We are looking forward to setting up business relationship with you and hope to provide you with the best service and solution. Let us make a better world for our industry!



## Contact us

Tel: +86-755-8981 8866 Fax: +86-755-8427 6832

Email & Skype: info@chipsmall.com Web: www.chipsmall.com

Address: A1208, Overseas Decoration Building, #122 Zhenhua RD., Futian, Shenzhen, China



**DDR3 DIMM  
Ejector Latch  
Extraction Tool**



**Application Tooling  
Specification Sheet**

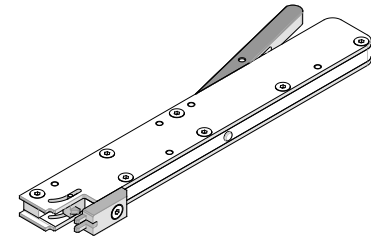

**Order No. 62100-1810**

**FEATURES**

- Tool provides for positive alignment to remove ejector latch.
- Low handle force to extract latch.
- Latch can be extracted without removing light pipe.
- For actuator extraction, use tool 62100-9150.

**SCOPE**

Products: DDR3 DIMM Socket 78689 Series Assembly (276 Circuit, Vertical SMT, T1.9mm).  
See Product List below for specific part numbers.

**Product List**

The following is a partial list of the product order numbers and their specifications this tool is designed to run.  
Updates to this list are available on [www.molex.com](http://www.molex.com).

Series No.	Assembly Order Number
78689	78689-0001

**Tool Setup**

The principal parts of the Actuator Extraction Tool are shown in Figure 1.

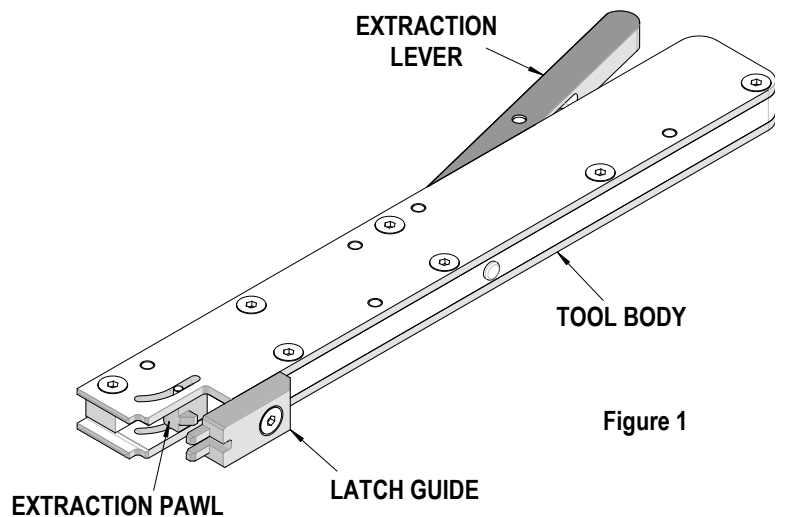

Figure 1

**Preparation**

Before using the extractor, the product must be prepared as follows.

1. Remove the memory card from the socket to be repaired. Also remove any neighboring memory card(s) on both sides of the socket to be repaired.
2. Remove the latch actuator from the socket to be repaired. The actuator extraction tool is 62100-9150.

3. Close the latch to be removed by pivoting it upwards.
4. The light pipes do not have to be removed.
5. The prepared product should look like Figure 2.

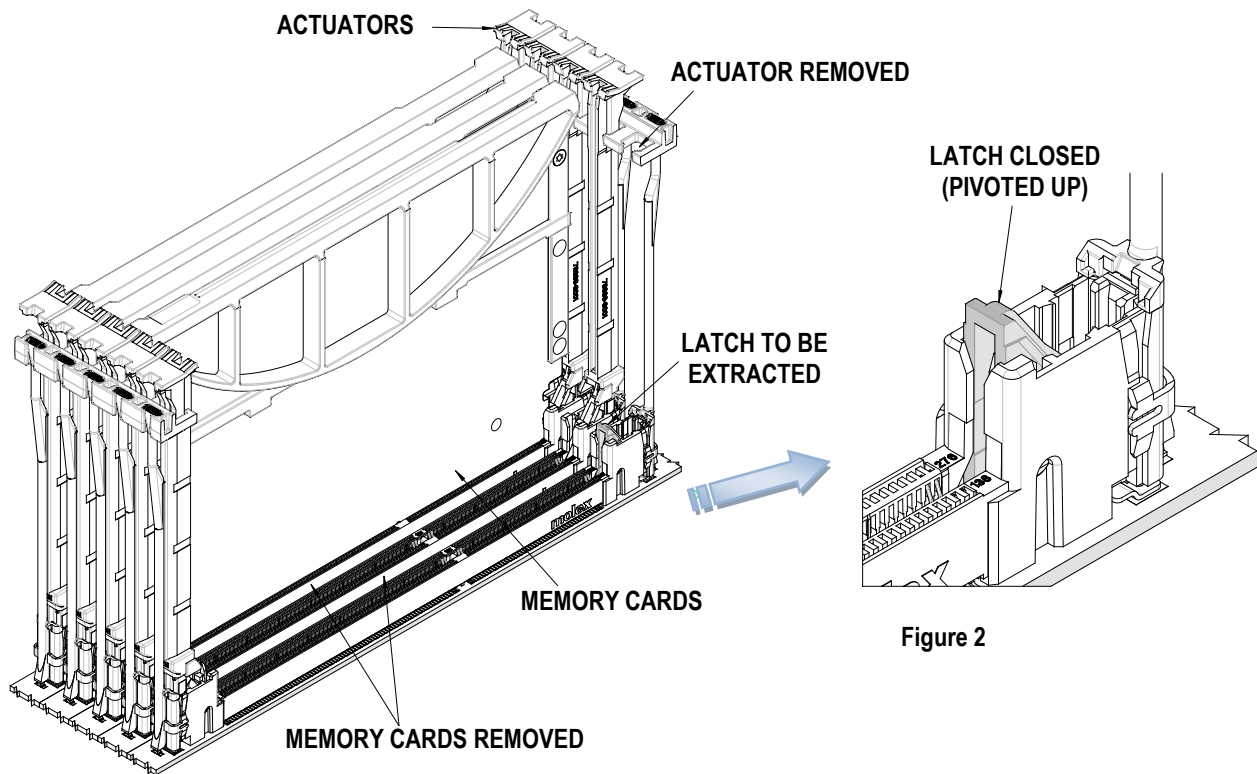

Figure 2

### Tool Operation

1. Align the groove in the bottom of the tool body with the memory socket and place the tool on the socket. The tool's latch guide fingers must enter the tower and the tool body must be against the tower. See Figure 3.

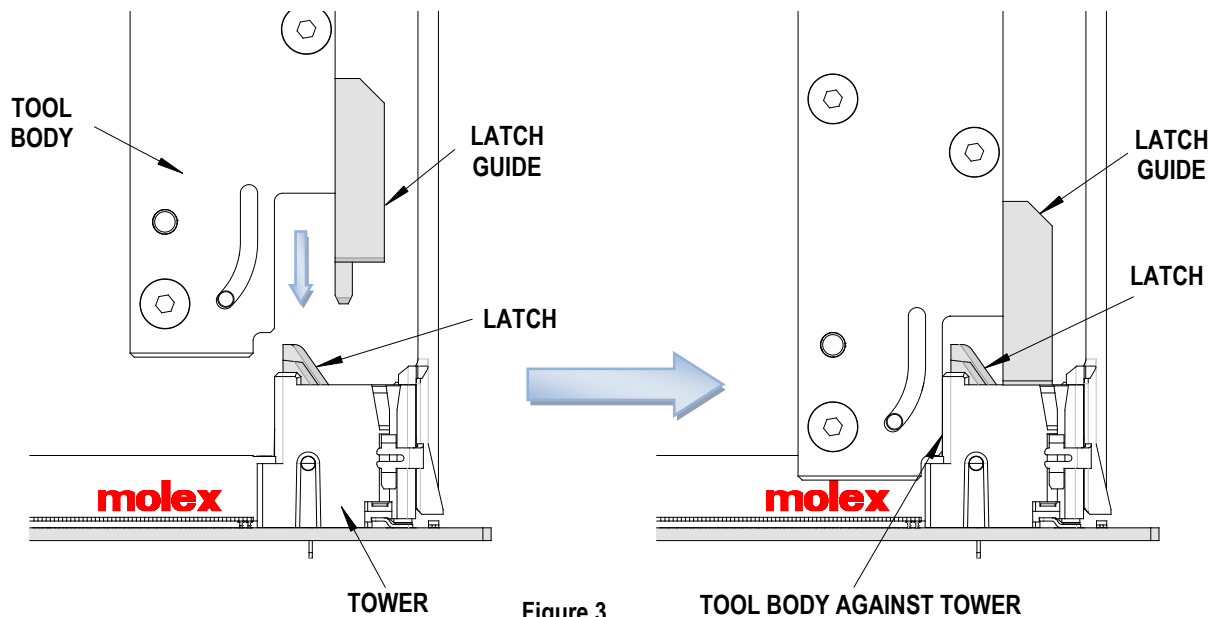
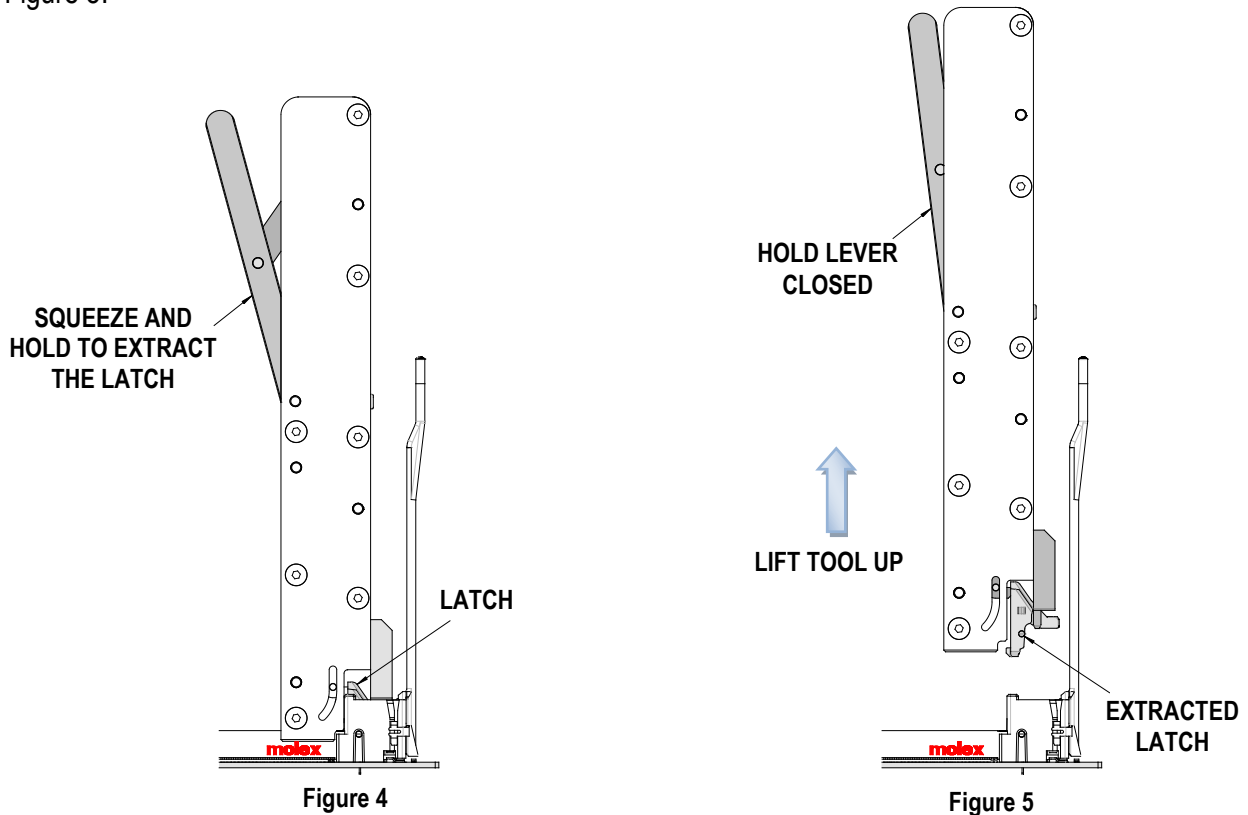

Figure 3

2. Squeeze the extraction lever towards the tool body to extract the latch. Do not release the lever. See Figure 4.
3. While holding the extraction lever closed, lift the extraction tool and the extracted latch out of the socket. See Figure 5.



4. With the tool away from the socket, release the extraction lever and discard the extracted latch.
5. Any plastic debris left in the socket must be removed (using a compressed air jet or vacuum) before installing the new latch.
6. The new latch can be installed in the socket by hand until it snaps into place.

**CAUTION:** Molex application tooling specifications are valid only when used with Molex connectors and tooling.

### Contact Information

For more information on Molex application tooling please contact Molex at 1-800-786-6539.

### Parts List

Ejector Latch Extraction Tool 62100-1810			
Item	Order No.	Description	Quantity
1	62100-1819	Latch Guide	1
2	62100-1818	Extraction Pawl	1
3	63600-4381	Pin 2mm diameter by 10mm long	1
4	63600-4380	Pin 2mm diameter by 5mm long	1

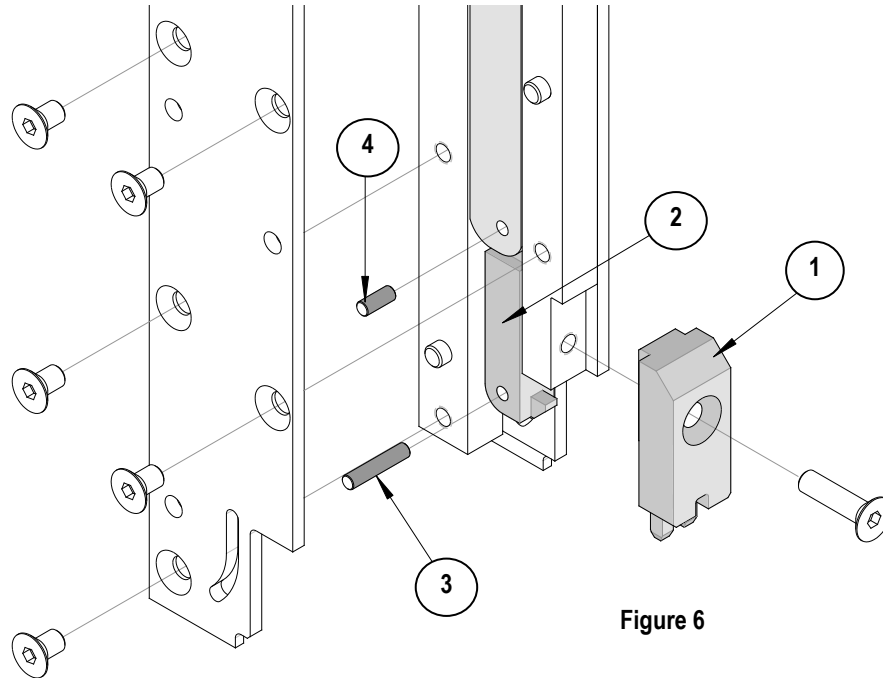

Visit our Web site at <http://www.molex.com>