



Chipsmall Limited consists of a professional team with an average of over 10 year of expertise in the distribution of electronic components. Based in Hongkong, we have already established firm and mutual-benefit business relationships with customers from,Europe,America and south Asia,supplying obsolete and hard-to-find components to meet their specific needs.

With the principle of “Quality Parts,Customers Priority,Honest Operation,and Considerate Service”,our business mainly focus on the distribution of electronic components. Line cards we deal with include Microchip,ALPS,ROHM,Xilinx,Pulse,ON,Everlight and Freescale. Main products comprise IC,Modules,Potentiometer,IC Socket,Relay,Connector.Our parts cover such applications as commercial,industrial, and automotives areas.

We are looking forward to setting up business relationship with you and hope to provide you with the best service and solution. Let us make a better world for our industry!



Contact us

Tel: +86-755-8981 8866 Fax: +86-755-8427 6832

Email & Skype: info@chipsmall.com Web: www.chipsmall.com

Address: A1208, Overseas Decoration Building, #122 Zhenhua RD., Futian, Shenzhen, China





Z-Power Extraction Tool Instruction Sheet Order No. 62100-5300

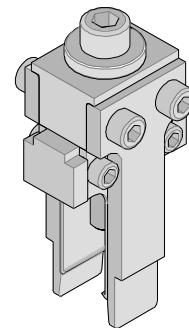

FEATURES

- Lightweight tool used in the Extraction a Z-Power Module in a PCB
- Removes connector without damage to the board

SCOPE

Products: Z-Power 76001 Series. See Product List below for specific application tools.

Product List

The following is a partial list of the product order numbers and their specifications this tool is designed to run. Updates to this list are available on www.molex.com.

Assembly Order Number	Description
76001-0006	Z-Power 6 Tail Assembly
76001-0010	Z-Power 10 Tail Assembly

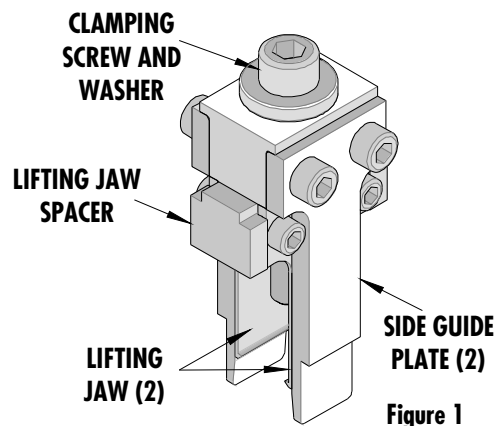

Figure 1

DESCRIPTION

The following Instructions are used for removing a Z-Power Module from a PCB.

Operation

Note: Be sure that all parts of the extraction tool will clear any components on the printed circuit board during use. Tape may also be placed over circuit traces or on the bottom of the extraction tool side guide plates for added protection of the printed circuit board.

1. Turn the #10-32 SHCS counter-clockwise (CCW) until half the lifting jaws are exposed below the side guide plates. Continue turning the #10-32 SHCS so the lifting jaw spacer is parallel to the power module. See Figure 2.

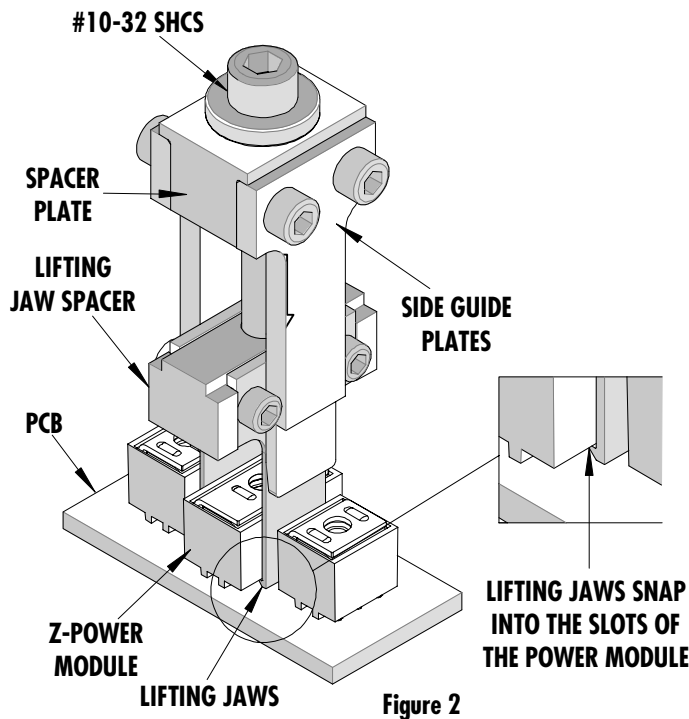

Figure 2

- Slide the lifting jaws down over the power module until the lifting jaws lock onto the slots at the base of the power module.

Note: The lifting jaws must snap into the slots of the power module so it can be lifted off the printed circuit board.

- Turn the #10-32 SHCS clockwise (CW) until the extraction tool side guide plates contact the printed circuit board. Continue turning the #10-32 SHCS so the lifting jaw spacer is parallel to the power module. See Figure 3.
- Continue turning the #10-32 SHCS until the power module is removed from the printed circuit board. See Figure 4.

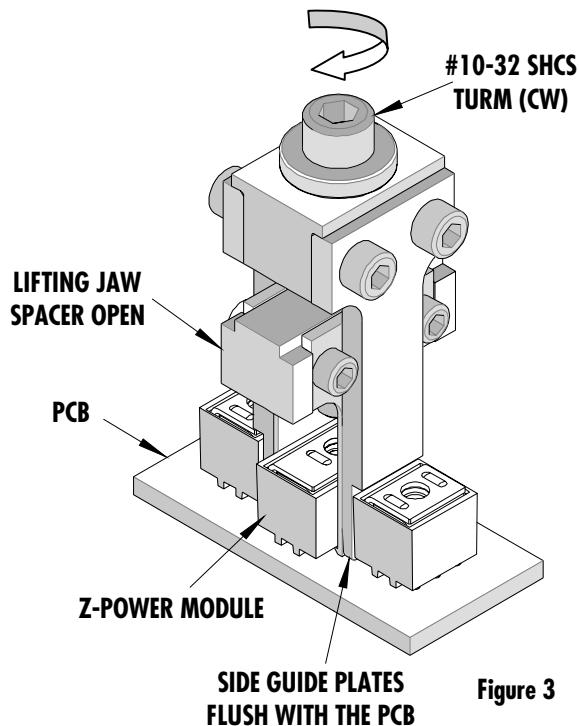

Figure 3

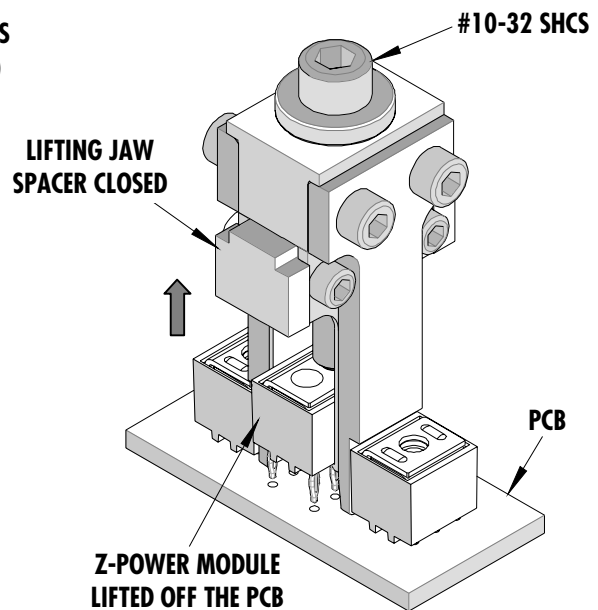

Figure 4

- Move the extraction tool away from the printed circuit board, then remove the power module from the extraction tool by turning the extraction tool on its side and slide the power module out.

Maintenance

It is recommended that each operator of the tool be made aware of, and responsible for, the following maintenance steps:

- Remove dust, moisture, and other contaminants with a clean brush, or soft, lint free cloth.
- Do not use any abrasive materials that could damage the tool.
- Make certain all pins; pivot points and bearing surfaces are protected with a thin coat of high quality machine oil. Do not oil excessively.
- When tool is not in use, store in a clean, dry area.

CAUTION: Molex specifications are valid only when used with Molex terminals, applicators and tooling.

PARTS LIST

Item	Order No	Description	Quantity
	62100-5300	Extraction Tool for Z-Power	(Figure 5)
1	62100-5301	Spacer Plate	1
2	62100-5303	Lifting Jaw Spacer	1
3	62100-5306	Lifting Jaw	2
4	62100-5308	Side Guide Plate	2
5	N/A	#10 Washer Hardened	1**
6	N/A	#4-40 by 3/16" Long SHCS	4**
7	N/A	#6-32 by 5/16" Long SHCS	4**
8	N/A	#10-32 by 1-3/8" Long SHCS	1**

** Available from an industrial supply company such as MSC (1-800-645-7270).

Assembly Drawing

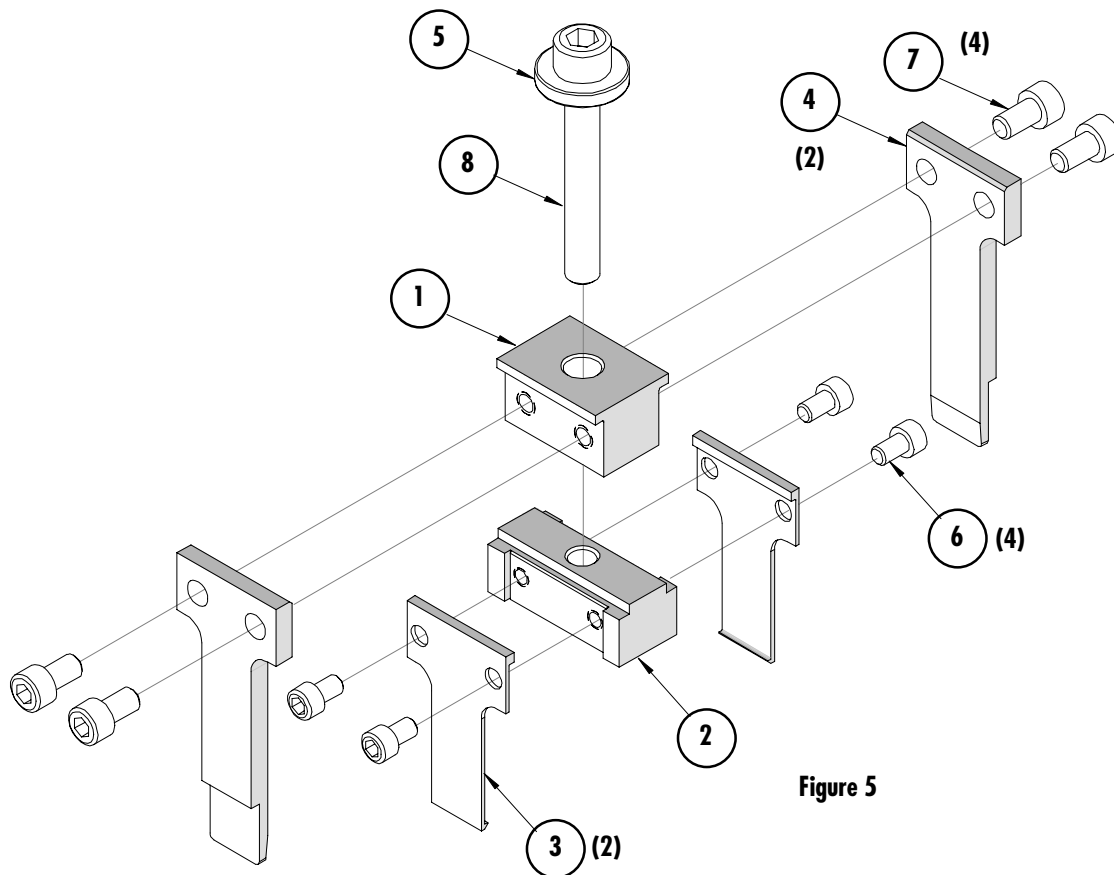

Figure 5

Americas Headquarters
 Lisle, Illinois 60532 U.S.A.
 1-800-78MOLEX
 amerinfo@molex.com

Far East North Headquarters
 Yamato, Kanagawa, Japan
 81-462-65-2324
 feninfo@molex.com

Far East South Headquarters
 Jurong, Singapore
 65-6-268-6868
 fesinfo@molex.com

European Headquarters
 Munich, Germany
 49-89-413092-0
 eurinfo@molex.com

Corporate Headquarters
 2222 Wellington Ct.
 Lisle, IL 60532 U.S.A.
 630-969-4550
 Fax: 630-969-1352

Visit our Web site at <http://www.molex.com>