



Chipsmall Limited consists of a professional team with an average of over 10 year of expertise in the distribution of electronic components. Based in Hongkong, we have already established firm and mutual-benefit business relationships with customers from,Europe,America and south Asia,supplying obsolete and hard-to-find components to meet their specific needs.

With the principle of “Quality Parts,Customers Priority,Honest Operation,and Considerate Service”,our business mainly focus on the distribution of electronic components. Line cards we deal with include Microchip,ALPS,ROHM,Xilinx,Pulse,ON,Everlight and Freescale. Main products comprise IC,Modules,Potentiometer,IC Socket,Relay,Connector.Our parts cover such applications as commercial,industrial, and automotives areas.

We are looking forward to setting up business relationship with you and hope to provide you with the best service and solution. Let us make a better world for our industry!



Contact us

Tel: +86-755-8981 8866 Fax: +86-755-8427 6832

Email & Skype: info@chipsmall.com Web: www.chipsmall.com

Address: A1208, Overseas Decoration Building, #122 Zhenhua RD., Futian, Shenzhen, China





EXTreme PowerMass™ Vertical Receptacle Power Terminal Removal Tool Instruction Sheet Order No. 62100-5900

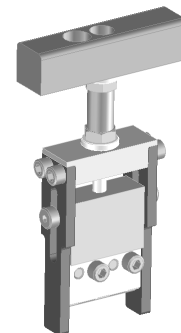

FEATURES

- % This tool is designed to remove the power terminals from the PC board after the connector housing is removed.
- % Removes terminals without damage to the board or holes.

SCOPE

Products: EXTreme PowerMass™ Vertical Receptacle Assemblies. See Product List below for specific part numbers.

Product List

The following is a partial list of the product order numbers and their specifications this tool is designed to run. Updates to this list are available on www.molex.com.

Series No.	Connector Order No.	Description
75545	75545-1000	80A Receptacle Assembly, tin tails
	75545-1001	80A Receptacle Assembly, tin-lead tails
	75545-1100	40A Receptacle Assembly, tin tails
	75545-1101	40A Receptacle Assembly, tin-lead tails
	75545-5100	40A Receptacle Assembly, tin tails
	75545-5101	40A Receptacle Assembly, tin-lead tails
75542	75542-1000	150A Receptacle Assembly, tin tails
	75542-1001	150A Receptacle Assembly, tin-lead tails
	75542-5000	150A Receptacle Assembly, tin tails
	75542-5001	150A Receptacle Assembly, tin-lead tails

DESCRIPTION

The Power Terminal Removal Tool clamps a pair of power terminals against an anvil then lifts the terminals out of the PCB using a screw-driven slide. The Terminal Removal Tool is shipped with the terminal clamp plates in the closed position, as shown in Figure 1.

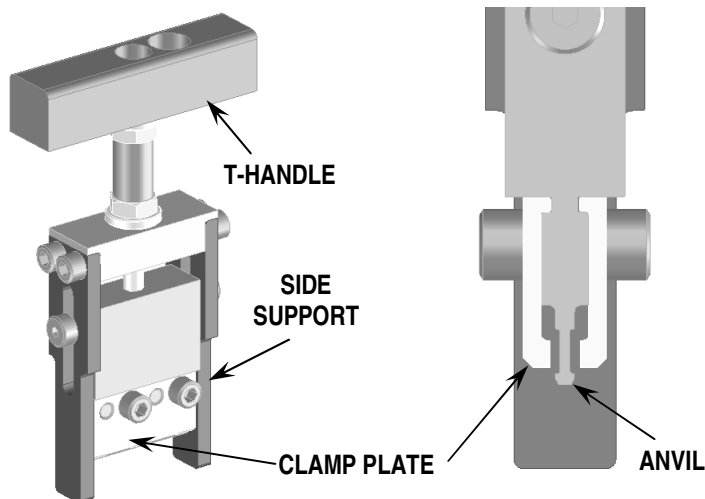

Figure 1

OPERATION

Note: Be sure that all parts of the Removal Tool will clear any components on the printed circuit board during use. Tape may also be placed over circuit traces or on the bottom of the side supports for added protection of the printed circuit board.

1. Remove the connector housing by gripping it with a pair of pliers and pulling it up from the terminals. See Figure 2.

Caution: Care must be taken during this procedure to prevent bending of the terminals that are left in place in the printed circuit board.

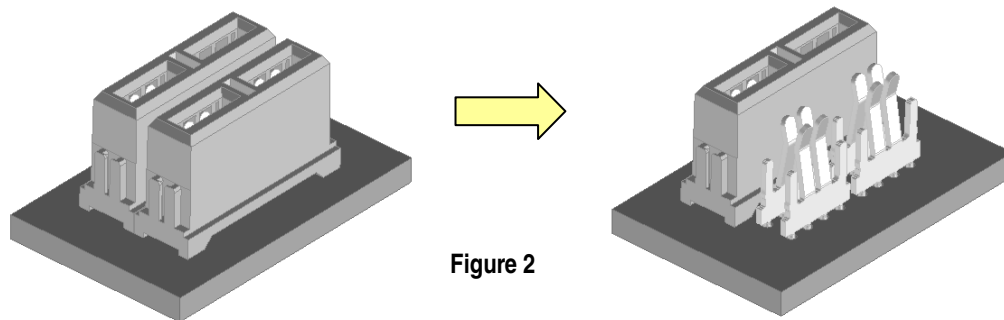

Figure 2

2. Using a 7/64" hex key, loosen the #6 SHCS holding the clamp plates. See Figure 3.
3. Before placing the Terminal Removal Tool into the terminals make sure the anvil is lowered. See Figure 3.
4. Position the Anvil Block between terminal rows. The clamp plate bottom rests on top of the terminal shoulder. See Figure 4.
5. Using a 7/64" hex key, tighten the (2) clamp plates. The clamp plates fit into a key slot in the anvil. Tighten the #6 SHCS so that the clamp plates "bite" into the terminals. Do not over tighten. See Figure 4.

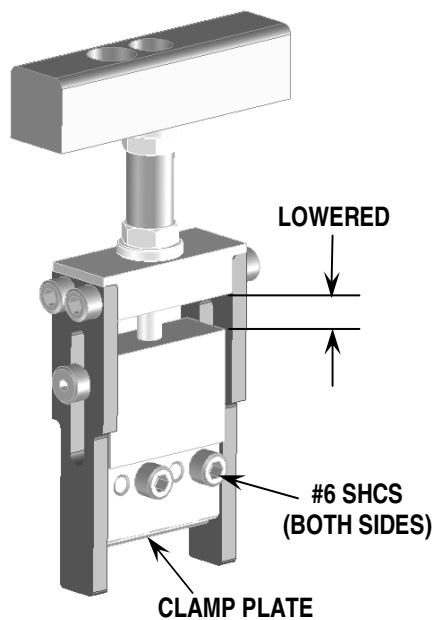

Figure 3

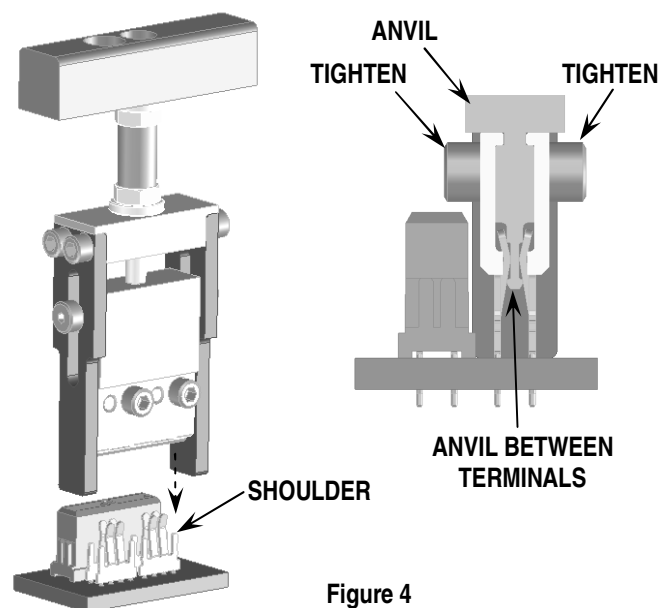

Figure 4

6. Position the Terminal Removal Tool so that the (2) side supports are resting on the printed circuit board.
7. Turn T-handle clockwise, making sure the threaded shaft goes into the threaded hole on top of the anvil.
8. Continue turning the T-Handle until the terminals lift up and are removed from the printed circuit board. See Figure 5.
9. Move the Removal Tool away from the printed circuit board. Then remove the terminals from the Removal Tool by loosening the #6 SHCS on the clamp plates and pulling out the terminals.
10. Extracted terminals should be discarded and not reused.

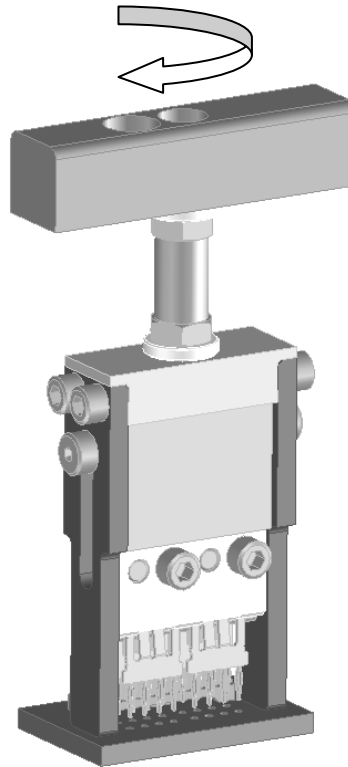

Figure 5

Maintenance

It is recommended that each operator of the tool be made aware of, and responsible for, the following maintenance steps:

1. Remove dust, moisture, and other contaminants with a clean brush, or soft, lint free cloth.
2. Do not use any abrasive materials that could damage the tool.
3. Make certain all pins; pivot points and bearing surfaces are protected with a thin coat of high quality machine oil. Do not oil excessively.
4. When tool is not in use, store in a clean, dry area.

CAUTION: Molex specifications are valid only when used with Molex terminals, applicators and tooling.

PARTS LIST

Item	Order No	Description	Quantity
	62100-5900	EXTreme PowerMass™ Terminal Removal Tool	Figure 6
1	62100-5401	Spacer Plate	1
2	62100-5404	T Handle	1
3	62100-5903	Anvil Block	1
4	62100-5906	Terminal Clamp Plate	2
5	62100-5908	Side Plate Guide	2
6	63700-4308	Shoulder Screw	2
7	63700-4312	Collar	1
8	63700-4313	Retainer	1
9	N/A	#8-32UNC Hex Nut	2**
10	N/A	#8-32UNC by 2" long set screw	1**
11	N/A	#6-32UNC by 3/8 long SHCS	4**
12	N/A	#6-32UNC by 1/4 long SHCS	4**
13	N/A	#8 Hardened Washer	2**

** Available from an industrial supply company such as MSC (1-800-645-7270).

Assembly Drawing

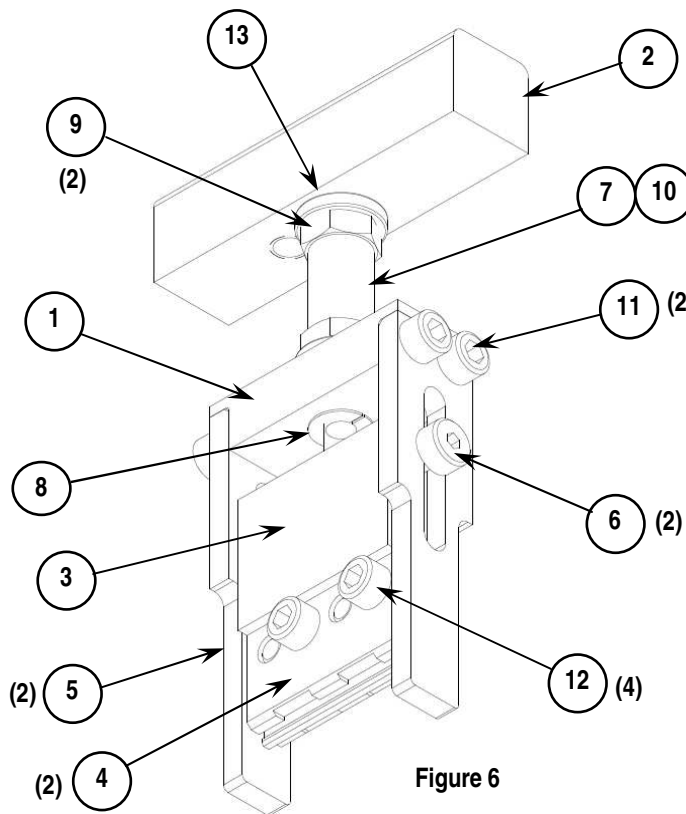

Figure 6

<p>Americas Headquarters Lisle, Illinois 60532 U.S.A. 1-800-78MOLEX amerinfo@molex.com</p>	<p>Far East North Headquarters Yamato, Kanagawa, Japan 81-462-65-2324 feninfo@molex.com</p>	<p>Far East South Headquarters Jurong, Singapore 65-6-268-6868 fesinfo@molex.com</p>	<p>European Headquarters Munich, Germany 49-89-413092-0 eurinfo@molex.com</p>	<p>Corporate Headquarters 2222 Wellington Ct. Lisle, IL 60532 U.S.A. 630-969-4550 Fax: 630-969-1352</p>
--	---	--	---	--

Visit our Web site at <http://www.molex.com>