



Chipsmall Limited consists of a professional team with an average of over 10 year of expertise in the distribution of electronic components. Based in Hongkong, we have already established firm and mutual-benefit business relationships with customers from,Europe,America and south Asia,supplying obsolete and hard-to-find components to meet their specific needs.

With the principle of "Quality Parts,Customers Priority,Honest Operation,and Considerate Service",our business mainly focus on the distribution of electronic components. Line cards we deal with include Microchip,ALPS,ROHM,Xilinx,Pulse,ON,Everlight and Freescale. Main products comprise IC,Modules,Potentiometer,IC Socket,Relay,Connector.Our parts cover such applications as commercial,industrial, and automotives areas.

We are looking forward to setting up business relationship with you and hope to provide you with the best service and solution. Let us make a better world for our industry!



Contact us

Tel: +86-755-8981 8866 Fax: +86-755-8427 6832

Email & Skype: info@chipsmall.com Web: www.chipsmall.com

Address: A1208, Overseas Decoration Building, #122 Zhenhua RD., Futian, Shenzhen, China



PLEASE CHECK WWW.MOLEX.COM FOR LATEST PART INFORMATION

Part Number: [62100-8500](#)
Status: **Active**
Description: Removal Tool for 12.5 Gbps Module, 200 Circuits

Documents:
[RoHS Certificate of Compliance \(PDF\)](#)

General

Product Family	Application Tooling
Series	T3002
Comments	See Tooling Specification (PDF) Above
Function	Extraction
Geographic Area	Global
Level of Automation	Manual
More Detailed Tech Information	applicationtooling@molex.com
Product Name	N/A
Survey	www.molex.com//review/apptool_survey.html
Tool Type	Handtool
UPC	883906916893

Material Info

Reference - Drawing Numbers

Application Tooling Documents	ATS-621008500
-------------------------------	---------------

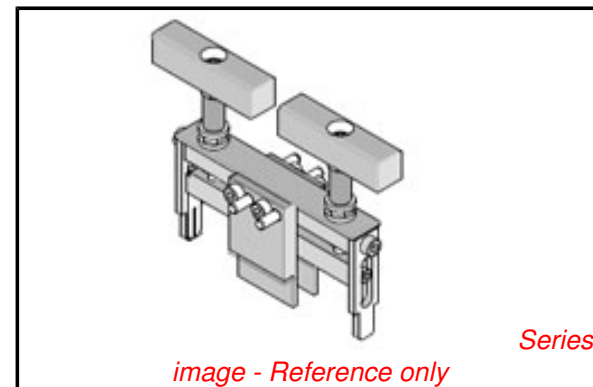

EU RoHS	China RoHS
Compliance Status	
Not Reviewed	
REACH SVHC	
Not Reviewed	
Low-Halogen Status	
Not Reviewed	

Need more information on product environmental compliance?

Email productcompliance@molex.com
 For a multiple part number RoHS Certificate of Compliance, [click here](#)

Please visit the [Contact Us](#) section for any non-product compliance questions.

Search Parts in this Series
[T3002Series](#)

Use With
[76691](#) EdgeLine® 12.5 Gbps Edge Card Connector

Application Tooling Description	FAQ Product #
0.80 mm Pitch EdgeLine® 12.5 Gbps Edge Card Connector, 200 Circuits, 1 Bay, PCB Mating Thickness 1.60mm	1706731200
0.80 mm Pitch EdgeLine® 12.5 Gbps Edge Card Connector, 200 Circuits, 1 Bay, PCB Mating Thickness 1.57mm	0766911200

This document was generated on 03/08/2013

PLEASE CHECK WWW.MOLEX.COM FOR LATEST PART INFORMATION