



Chipsmall Limited consists of a professional team with an average of over 10 year of expertise in the distribution of electronic components. Based in Hongkong, we have already established firm and mutual-benefit business relationships with customers from,Europe,America and south Asia,supplying obsolete and hard-to-find components to meet their specific needs.

With the principle of “Quality Parts,Customers Priority,Honest Operation,and Considerate Service”,our business mainly focus on the distribution of electronic components. Line cards we deal with include Microchip,ALPS,ROHM,Xilinx,Pulse,ON,Everlight and Freescale. Main products comprise IC,Modules,Potentiometer,IC Socket,Relay,Connector.Our parts cover such applications as commercial,industrial, and automotives areas.

We are looking forward to setting up business relationship with you and hope to provide you with the best service and solution. Let us make a better world for our industry!



## Contact us

Tel: +86-755-8981 8866 Fax: +86-755-8427 6832

Email & Skype: info@chipsmall.com Web: www.chipsmall.com

Address: A1208, Overseas Decoration Building, #122 Zhenhua RD., Futian, Shenzhen, China





**VHDM Right Angle Male Header  
(74600 SERIES)  
Single Wafer Insertion Tool  
Instruction Sheet  
Order No 62202-1060**

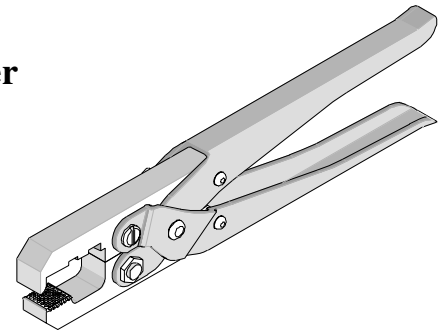

**FEATURES**

- A pliers-type tool used in the repair of damaged connectors to replace individual wafers, which reduces connector replacement costs
- Lightweight manual tool that is easy to use
- High quality construction that will provide longevity with proper care of hand tool

**Scope:**

2.00mm (.079") Pitch VHDM®\* Board-to-Board Backplane Header, Right Angle, Male, 6 Row, Series 74600

\*Note VHDM and VHDM-HSD are registered trademarks of Amphenol Corporation.

The following is a Partial List of the Product Part Numbers and their specifications that this tooling is designed to repair. We will be adding to this list and an up to date copy is available on [www.molex.com](http://www.molex.com).

Connector 74600- Series Order No.							
74600-1000	74600-1038	74600-1082	74600-1118	74600-1153	74600-1186	74600-1215	74600-1249
74600-1001	74600-1039	74600-1086	74600-1120	74600-1154	74600-1189	74600-1216	74600-1250
74600-1002	74600-1040	74600-1087	74600-1121	74600-1156	74600-1190	74600-1217	74600-1254
74600-1003	74600-1043	74600-1090	74600-1122	74600-1157	74600-1191	74600-1220	74600-1260
74600-1010	74600-1047	74600-1091	74600-1124	74600-1159	74600-1192	74600-1221	74600-1264
74600-1013	74600-1048	74600-1092	74600-1125	74600-1160	74600-1193	74600-1225	74600-1265
74600-1014	74600-1049	74600-1093	74600-1126	74600-1163	74600-1194	74600-1226	74600-1267
74600-1015	74600-1050	74600-1096	74600-1130	74600-1169	74600-1197	74600-1228	74600-1270
74600-1016	74600-1051	74600-1097	74600-1131	74600-1170	74600-1198	74600-1230	74600-1276
74600-1018	74600-1052	74600-1098	74600-1134	74600-1173	74600-1199	74600-1231	74600-1281
74600-1020	74600-1053	74600-1100	74600-1135	74600-1174	74600-1200	74600-1232	74600-1282
74600-1022	74600-1066	74600-1103	74600-1136	74600-1175	74600-1201	74600-1233	74600-1283
74600-1023	74600-1068	74600-1104	74600-1137	74600-1176	74600-1203	74600-1234	74600-1284
74600-1025	74600-1070	74600-1105	74600-1138	74600-1177	74600-1204	74600-1235	74600-1285
74600-1029	74600-1071	74600-1106	74600-1139	74600-1180	74600-1206	74600-1238	74600-288
74600-1033	74600-1073	74600-1111	74600-1140	74600-1182	74600-1207	74600-1242	
74600-1034	74600-1074	74600-1112	74600-1145	74600-1183	74600-1208	74600-1243	
74600-1035	74600-1080	74600-1116	74600-1150	74600-1184	74600-1209	74600-1244	
74600-1037	74600-1081	74600-1117	74600-1151	74600-1185	74600-1212	74600-1245	

**Decription:**

The 62202-1060 VHDM single wafer insertion tool is a simple pliers type tool for inserting individual wafers (up to three) in a VHDM right angle male header assembly. The tool is approximately 203mm (8 in.) long by 51mm (2 in.) wide (closed) by 25 mm (1 in.) thick and weighs .48 kg (1 lb).

**OPERATION:**

1. To insert a wafer into a header assembly, load it into position with the pins entering the holes on the PC board while aligning the wafer with the other wafers in the header. Up to three wafers can be inserted at the same time.
2. When the wafers are in position, place the 62202-1060-insertion tool over the wafers to be inserted. It is important to hold the tool so that it is parallel to the wafers in the header and not interfering with the features of the wafers. If the loaded wafer pins protrude below the board, the lower jaw of the insertion tool has clearance holes to clear for them. Be careful not to damage the pins when locating the tool. See Figure 1.
3. With the tool in place, carefully squeeze the handles until the wafer is pressed flush with the adjacent wafers.
4. When all the wafers are inserted in the header, the upper and lower stiffeners must then be reinstalled.
5. See 62201-0999 VHDM and VHDM-HSD Installation Tooling Manual for additional repair tools and information.

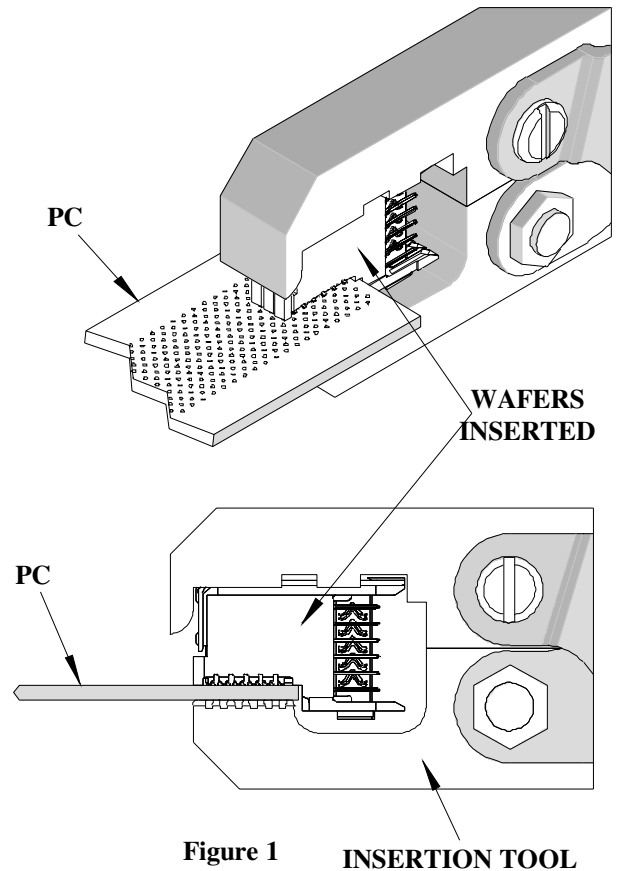

Figure 1 INSERTION TOOL

<b>Americas Headquarters</b> Lisle, Illinois 60532 U.S.A. 1-800-78MOLEX amerinfo@molex.com	<b>Far East North Headquarters</b> Yamato, Kanagawa, Japan 81-462-65-2324 feninfo@molex.com	<b>Far East South Headquarters</b> Jurong, Singapore 65-6-268-6868 fesinfo@molex.com	<b>European Headquarters</b> Munich, Germany 49-89-413092-0 eurinfo@molex.com	<b>Corporate Headquarters</b> 2222 Wellington Ct. Lisle, IL 60532 U.S.A. 630-969-4550
---	--	---	--	--

Visit our Web site at <http://www.molex.com>