



Chipsmall Limited consists of a professional team with an average of over 10 year of expertise in the distribution of electronic components. Based in Hongkong, we have already established firm and mutual-benefit business relationships with customers from,Europe,America and south Asia,supplying obsolete and hard-to-find components to meet their specific needs.

With the principle of “Quality Parts,Customers Priority,Honest Operation,and Considerate Service”,our business mainly focus on the distribution of electronic components. Line cards we deal with include Microchip,ALPS,ROHM,Xilinx,Pulse,ON,Everlight and Freescale. Main products comprise IC,Modules,Potentiometer,IC Socket,Relay,Connector.Our parts cover such applications as commercial,industrial, and automotives areas.

We are looking forward to setting up business relationship with you and hope to provide you with the best service and solution. Let us make a better world for our industry!



Contact us

Tel: +86-755-8981 8866 Fax: +86-755-8427 6832

Email & Skype: info@chipsmall.com Web: www.chipsmall.com

Address: A1208, Overseas Decoration Building, #122 Zhenhua RD., Futian, Shenzhen, China





DaughterCard Receptacle Single Wafer Removal Tool Instruction Sheet Order No 62202-2083

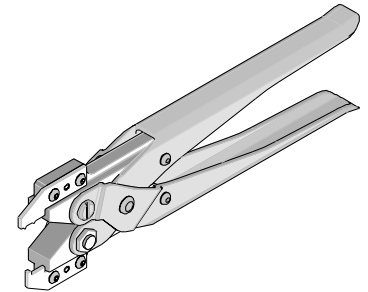

FEATURES

- A pliers-type tool used in the repair of damaged connectors to remove individual wafers, which reduces connector replacement costs
- Lightweight manual tool that is easy to use
- High quality construction that will provide longevity with proper care of hand tool
- See 62202-2000 GbX® Backplane and DaughterCard Installation Tooling Operation Manual for more information on tooling, presses and repair

SCOPE

Products: GbX®* Connector System for 2 pair series. See Product List below for specific part numbers.

*GbX and VHDM-HSD are a registered trademark of Amphenol Corporation.

Product List

The following is a partial list of the product order numbers and their specifications this tool is designed to run. Updates to this list are available on www.molex.com.

Connector Series No.	2- Pair Connector Order No.						
75650	75650-0001	75650-0014	75650-0024	75650-0049	75650-0056	75650-0064	75650-0071
	75650-0002	75650-0015	75650-0036	75650-0050	75650-0059	75650-0065	
	75650-0005	75650-0016	75650-0041	75650-0051	75650-0060	75650-0066	
	75650-0007	75650-0017	75650-0044	75650-0052	75650-0061	75650-0068	
	75650-0012	75650-0021	75650-0046	75650-0054	75650-0062	75650-0069	
	75650-0013	75650-0023	75650-0048	75650-0055	75650-0063	75650-0070	
75676	75676-0011	75676-0014	75676-0016	75676-0018	75676-0020	75676-0023	
	75676-0013	75676-0015	75676-0017	75676-0019	75676-0022		
75874	75874-0001	75874-0005	75874-0008	75874-0010	75874-0014	75874-0016	75874-0018
	75874-0002	75874-0007	75874-0009	75874-0013	75874-0015	75874-0015	

DESCRIPTION:

The 62202-2083 GbX® single wafer removal tool is a simple pliers- type tool for removing individual wafers from GbX® DaughterCard assemblies. The tool is approximately 203mm (8 in.) long by 51mm (2 in.) wide (closed) by 25mm (1 in.) thick and weighs .48 kg (1 lb).

OPERATION:

1. Before removing individual wafers from a DaughterCard assembly, you must first remove the stiffener. (See 62202-2900 (2-pair), Stiffener Removal Tool).
2. After removing the stiffener, identify the GbX wafer that needs to be replaced.

NOTE: Marking the defective wafer with white correction fluid or other similar material will aid in the removal process.

- Position the Wafer Removal Tool over the defective wafer with the teeth in the jaws over the “V” slots on the end of the wafer. See Figure 1.

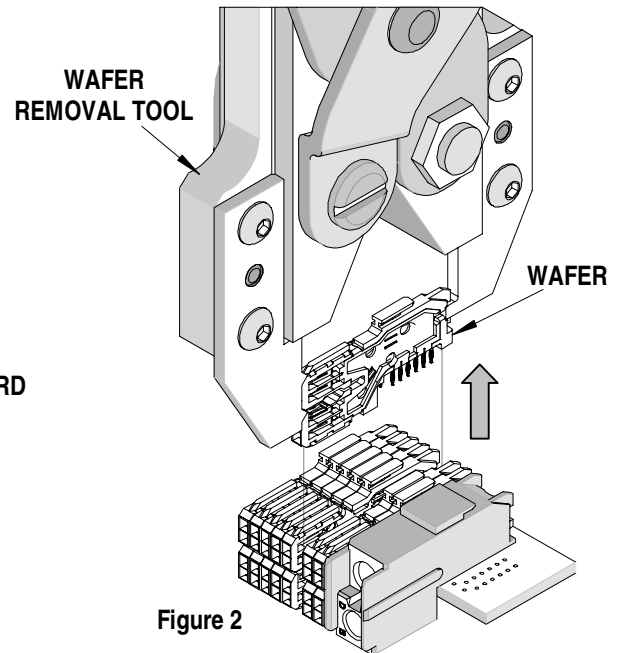
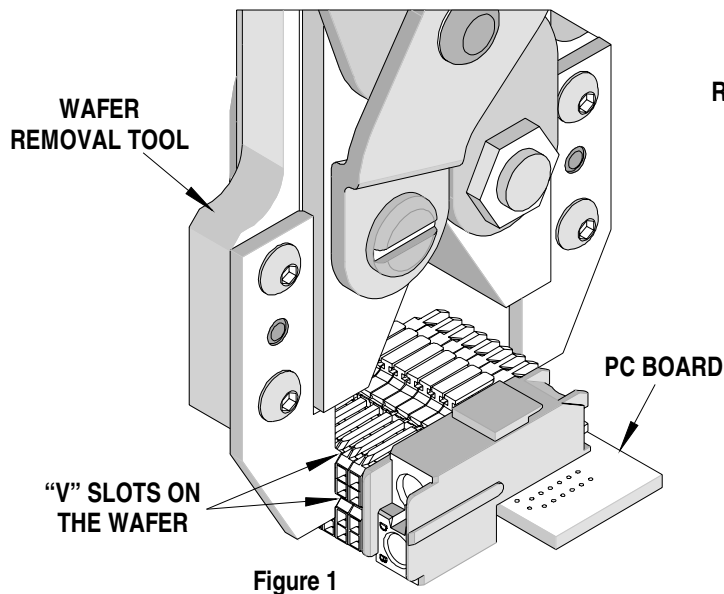

- While holding the tool in position over the wafer, squeeze the handles until the jaws clamp the defective wafer.
- While applying pressure to the handles, pull straight up until the wafer slips out of the assembly. See Figure 2.
- It may be necessary to also remove and replace adjacent wafers as they are easily damaged in the process of removal.
- Refer to 62202-2000 GbX® Backplane and DaughterCard Installation Tooling Operation Manual for proper operation, maintenance, and options of this tool.

Maintenance

It is recommended that each operator of the tool be made aware of, and responsible for, the following maintenance steps:

- Remove dust, moisture, and other contaminants with a clean brush, or soft, lint free cloth.
- Do not use any abrasive materials that could damage the tool.
- Make certain all pins; pivot points and bearing surfaces are protected with a thin coat of high quality machine oil. Do not oil excessively.
- When tool is not in use, store in a clean, dry area.
- There are no repair parts available for this tool. Should the tool be damaged a new tool is required.

CAUTION: Molex specifications are valid only when used with Molex connectors and tooling.

Americas Headquarters
Lisle, Illinois 60532 U.S.A.
1-800-78MOLEX
amerinfo@molex.com

Far East North Headquarters
Yamato, Kanagawa, Japan
81-462-65-2324
feninfo@molex.com

Far East South Headquarters
Jurong, Singapore
65-6-268-6868
fesinfo@molex.com

European Headquarters
Munich, Germany
49-89-413092-0
eurinfo@molex.com

Corporate Headquarters
2222 Wellington Ct.
Lisle, IL 60532 U.S.A.
630-969-4550
Fax: 630-969-1352

Visit our Web site at <http://www.molex.com>

