



Chipsmall Limited consists of a professional team with an average of over 10 year of expertise in the distribution of electronic components. Based in Hongkong, we have already established firm and mutual-benefit business relationships with customers from,Europe,America and south Asia,supplying obsolete and hard-to-find components to meet their specific needs.

With the principle of “Quality Parts,Customers Priority,Honest Operation,and Considerate Service”,our business mainly focus on the distribution of electronic components. Line cards we deal with include Microchip,ALPS,ROHM,Xilinx,Pulse,ON,Everlight and Freescale. Main products comprise IC,Modules,Potentiometer,IC Socket,Relay,Connector.Our parts cover such applications as commercial,industrial, and automotives areas.

We are looking forward to setting up business relationship with you and hope to provide you with the best service and solution. Let us make a better world for our industry!



Contact us

Tel: +86-755-8981 8866 Fax: +86-755-8427 6832

Email & Skype: info@chipsmall.com Web: www.chipsmall.com

Address: A1208, Overseas Decoration Building, #122 Zhenhua RD., Futian, Shenzhen, China





**2-by-1
zQSFP+
Insertion Tool**

**Application Tooling
Specification Sheet**

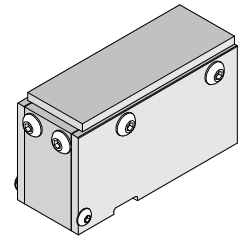

Order No. 62202-5240

FEATURES

- Lightweight tool used in the insertion of a zQSFP+ connector in a PCB
- Inserts connector to a PCB without damage to the board
- Use tool 62203-0390 for removing connectors

SCOPE

Products: Quad Small Form-factor Pluggable zQSFP+ Cage Assembly, 2-by 1 Multi-Port Connector, 2 Press Fit Rear Legs, Elastomeric Gasket for SAN Applications.

Series No.	Connector Order No.			
171565	171565-1001	171565-1002	171565-1003	171565-7102
171722	171722-1001	171722-1002	171722-1003	171722-1062

Notes:

1. See the following pages for tooling operation instructions.
2. These tools require a "Keep Out Zone" around the connector free of components. The rear of the connector should be .197" (5.0mm). The right and left sides should be .14" (3.5mm). See Figure 1.

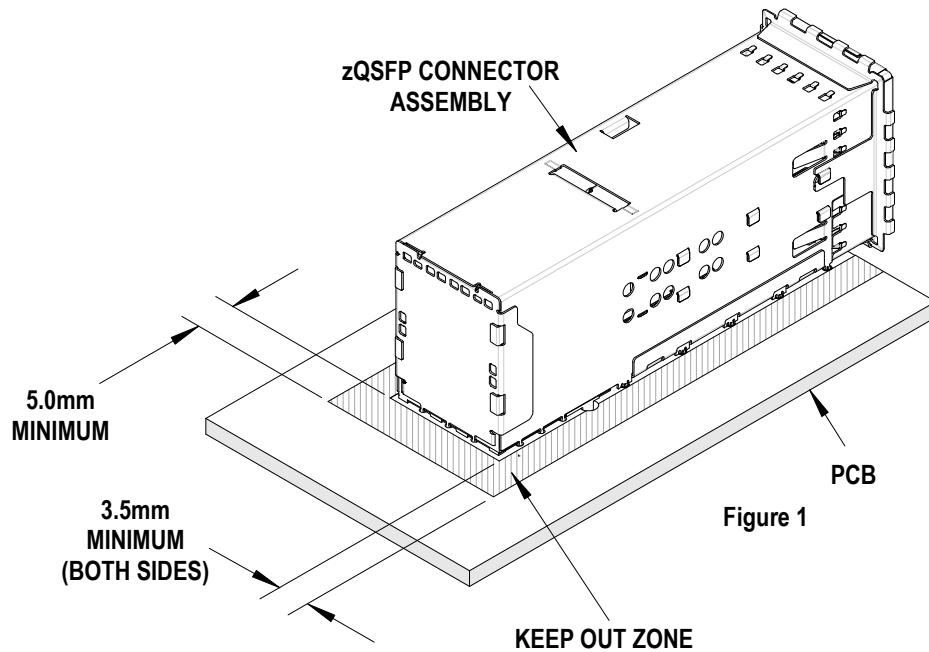

Description

The following instructions are used for inserting the 2 by 1 connector into a PCB.

Operation

1. Place a connector assembly on the PCB.
2. Place the tool on the connector assembly (closed end to the back end of the connector). See Figure 2.
3. Place tool, connector, and PCB, in a press of suitable size and force, and seat the connector assembly as shown. The support plate (furnished by the customer) under the PCB must have clearance for the connector pins as they pass through the PCB.

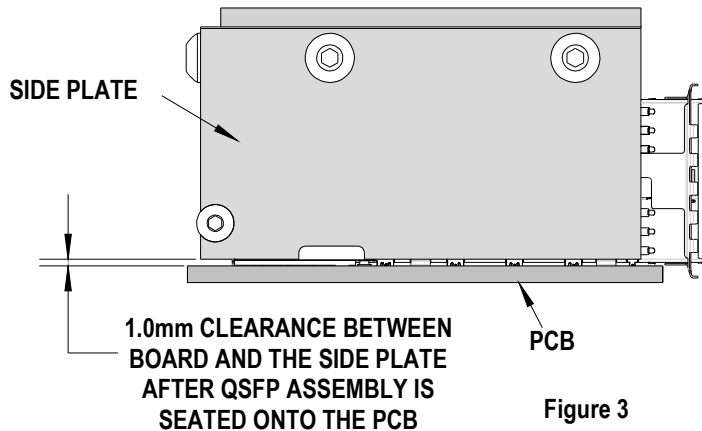
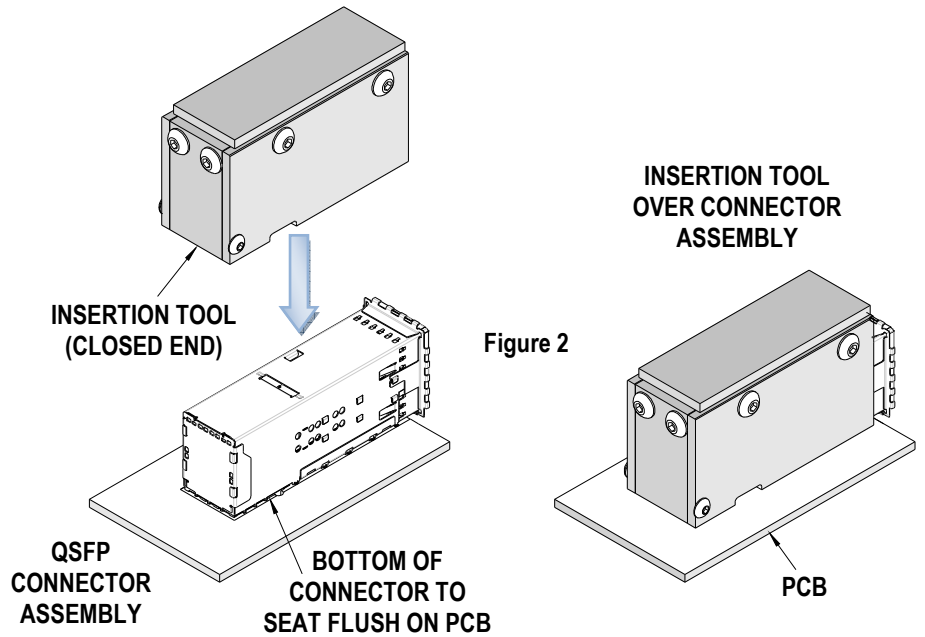

Clearance

Use this tool only with a press that has a predetermined shut height when seating a QSFP Assembly on a PCB. See figure 3. Allowing the Press-In Tool to stop on the board will result in damage the QSFP cage and terminals being over seated.

CAUTION: Molex application tooling specifications are valid only when used with Molex connectors and tooling.

Application Tooling Support

Phone: +1-402-458-TOOL (8665)
 E-Mail: applicationtooling@molex.com
 Website: www.molex.com/applicationtooling