



Chipsmall Limited consists of a professional team with an average of over 10 year of expertise in the distribution of electronic components. Based in Hongkong, we have already established firm and mutual-benefit business relationships with customers from,Europe,America and south Asia,supplying obsolete and hard-to-find components to meet their specific needs.

With the principle of “Quality Parts,Customers Priority,Honest Operation,and Considerate Service”,our business mainly focus on the distribution of electronic components. Line cards we deal with include Microchip,ALPS,ROHM,Xilinx,Pulse,ON,Everlight and Freescale. Main products comprise IC,Modules,Potentiometer,IC Socket,Relay,Connector.Our parts cover such applications as commercial,industrial, and automotives areas.

We are looking forward to setting up business relationship with you and hope to provide you with the best service and solution. Let us make a better world for our industry!



Contact us

Tel: +86-755-8981 8866 Fax: +86-755-8427 6832

Email & Skype: info@chipsmall.com Web: www.chipsmall.com

Address: A1208, Overseas Decoration Building, #122 Zhenhua RD., Futian, Shenzhen, China



**CXP™ and zCXP™
Connector Assembly
(Long)
Removal Tool**



**Application Tooling
Specification Sheet**

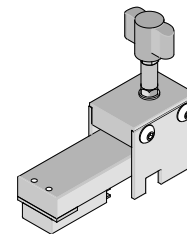

Order No. 62203-0230

FEATURES

- Removes the CXP™ and zCXP™(long) connector assemblies from a PCB
- Removes connector from in a PCB without damage to the board
- Use tool 62203-0031 or 62203-0032 for inserting connectors

SCOPE

Products: CXP™ and zCXP™, Integrated Cage and Connector Assembly, Press-Fit, 84 Circuit. See Product List below for specific part numbers.

Product List

The following is a partial list of the product order numbers and their specifications this tool is designed to run. Updates to this list are available on www.molex.com.

Connector Series No.	Assembly Order No.	
170502	170502-0001	170502-1001
173159	173159-0001	173159-0002

Tool Setup

The tooling arrangement in this removal tool is determined by the module and component placement on the PCB. There is a “Keep-Out Zone” that needs to be clear of the other components when using the extraction tool. See the shaded area in Figure 1.

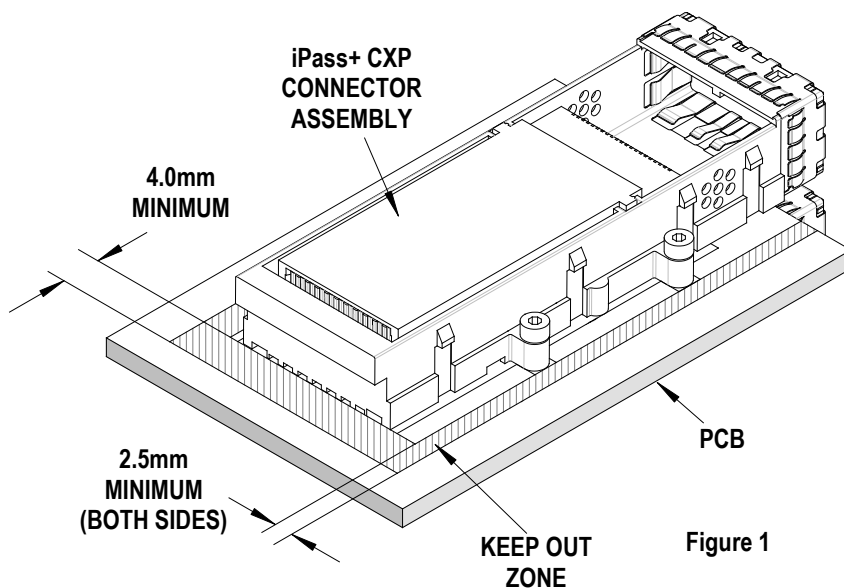

Figure 1

Note: Be sure that all parts of the removal tool will clear any components on the printed circuit board during use. Tape may be placed over circuit traces or on the bottom of the side plates for added protection of the printed circuit board.

Note: M2 screws must be removed before removing the connector.

The (long) connector assembly is held to the “short” assembly with (4) M2 screws. Before any removal operation is done, these M2 screws must be removed. See Figure 2.

Operation

1. Disassemble the upper tooling from the support tooling by turning the wing knob counterclockwise (CCW) until the halves separate.
2. Remove the rear clamp by turning the thumb screw counterclockwise (CCW). See Figure 3.
Note: the thumb screw is captive in the rear clamp to prevent loss.

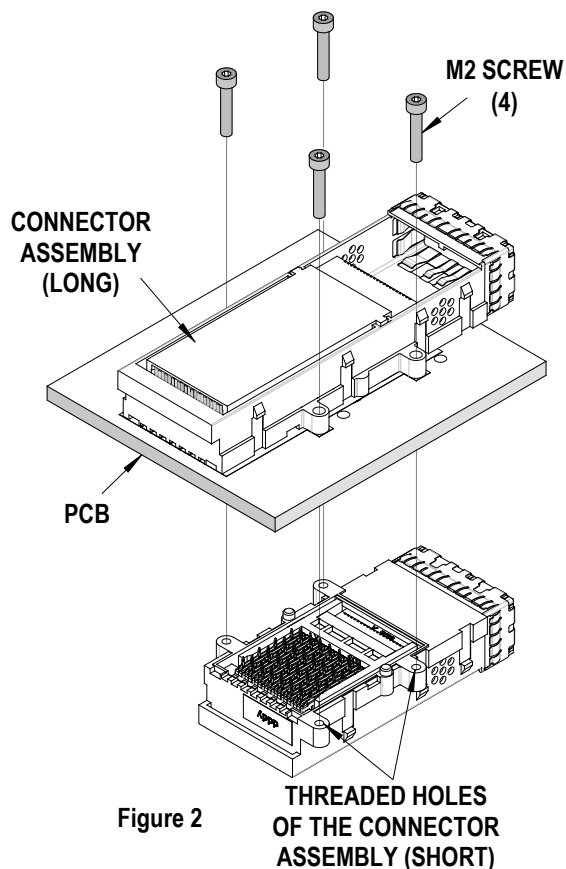

Figure 2

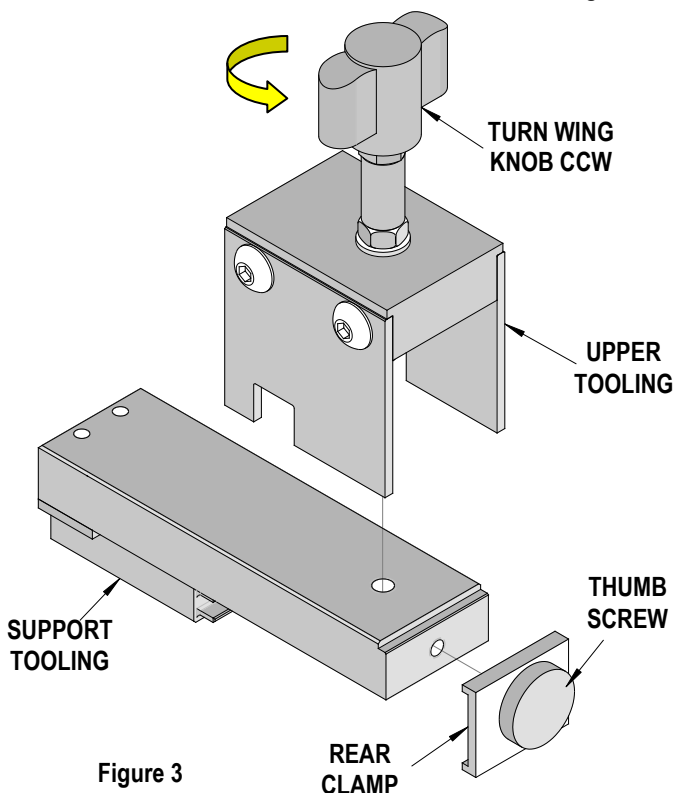

Figure 3

3. Insert the support tooling into the connector assembly until it is fully seated. See Figure 3. The tooling will “snap” into the connector when fully seated.

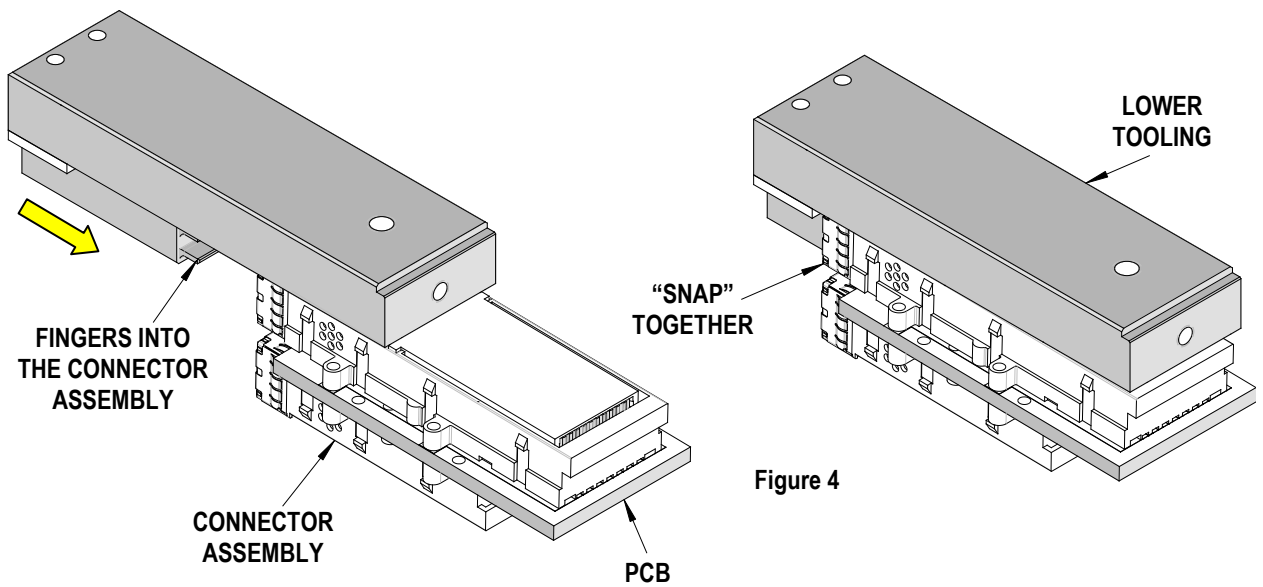

Figure 4

4. Place the rear clamp on the support tooling and tighten the thumb screw. The “lip” of the clamp must engage the edge of the connector. See Figure 5.
5. Place the upper tooling over the support tooling, so the lift screw is inline with the threaded hole in the support tooling and the cut-outs in the sides of the upper tooling clear the lugs of the connector. See Figure 5.

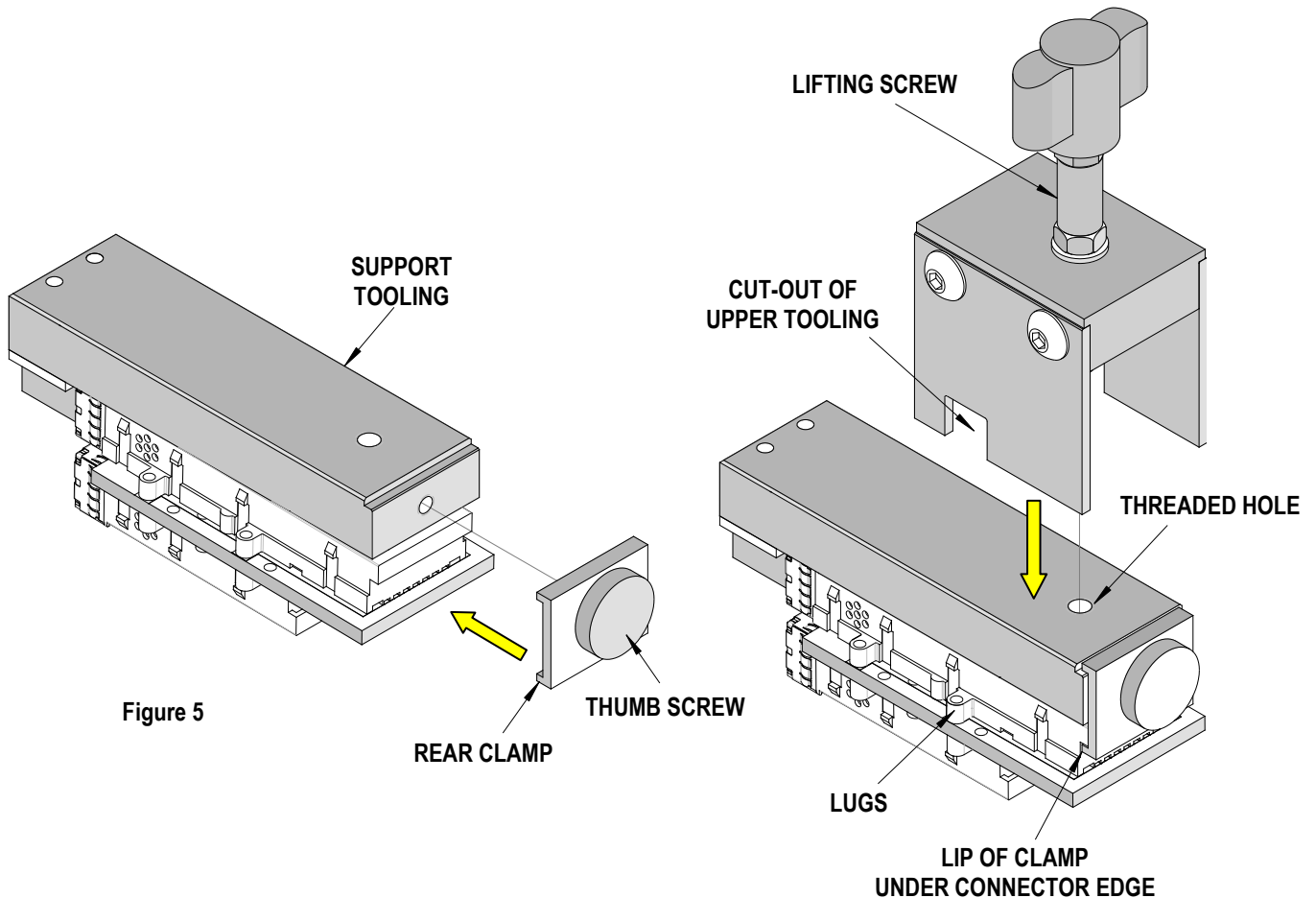

Figure 5

6. Turn the wing knob clockwise until the sides of the upper tooling contact the PCB. Continue turning until the connector is removed from the PCB. See Figure 6.

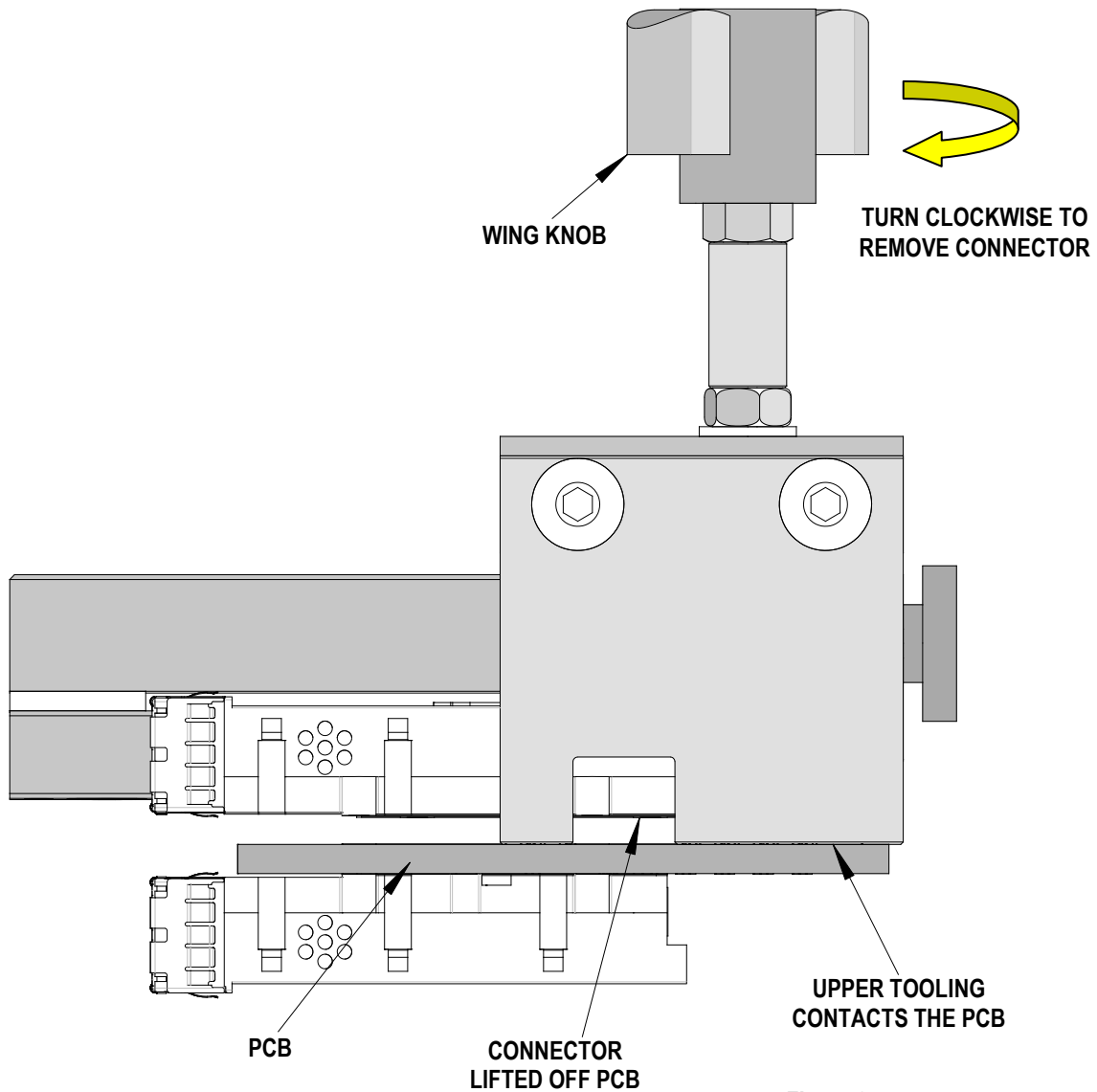

Figure 6

CAUTION: Molex application tooling specifications are valid only when used with Molex connectors and tooling.

Contact Information

For more information on Molex application tooling please contact Molex at 1-800-786-6539.

<http://www.molex.com>