



Chipsmall Limited consists of a professional team with an average of over 10 year of expertise in the distribution of electronic components. Based in Hongkong, we have already established firm and mutual-benefit business relationships with customers from,Europe,America and south Asia,supplying obsolete and hard-to-find components to meet their specific needs.

With the principle of “Quality Parts,Customers Priority,Honest Operation,and Considerate Service”,our business mainly focus on the distribution of electronic components. Line cards we deal with include Microchip,ALPS,ROHM,Xilinx,Pulse,ON,Everlight and Freescale. Main products comprise IC,Modules,Potentiometer,IC Socket,Relay,Connector.Our parts cover such applications as commercial,industrial, and automotives areas.

We are looking forward to setting up business relationship with you and hope to provide you with the best service and solution. Let us make a better world for our industry!



Contact us

Tel: +86-755-8981 8866 Fax: +86-755-8427 6832

Email & Skype: info@chipsmall.com Web: www.chipsmall.com

Address: A1208, Overseas Decoration Building, #122 Zhenhua RD., Futian, Shenzhen, China



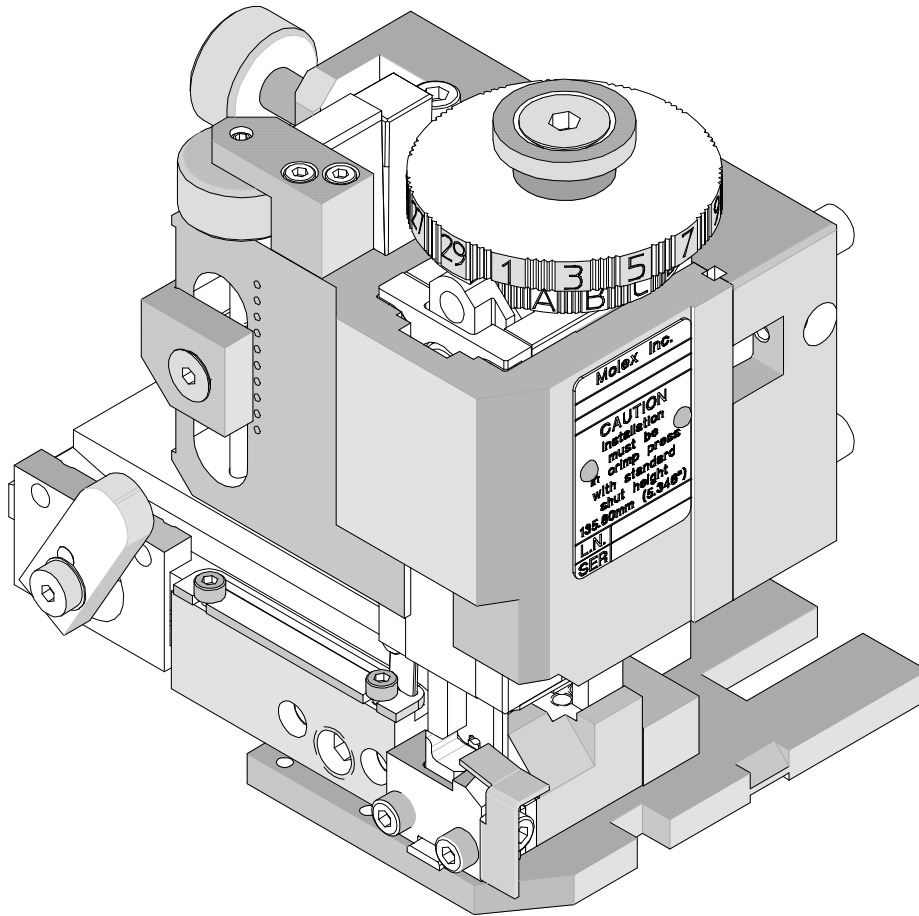

















FineAdjust™ APPLICATOR
Operation Manual
Order No 63800-4900









- Description
- Operation
- Maintenance

Safety Warnings and Information

	<p>Read and understand all of the instructions and safety information in this manual before operating or servicing this tool.</p> <p style="text-align: center;"><u>Keep this manual available when using this tool.</u></p> <p>Replacement manuals are available for download at no charge at www.molex.com.</p>
---	---

SAFETY ALERT SYMBOL	
<p>This symbol is used to call your attention to hazards or unsafe practices which could result in an injury or property damage. The signal word, defined below, indicates the severity of the hazard. The message after the signal word provides information for preventing or avoiding the hazard.</p>	
 DANGER	<p>DANGER: Indicates an imminently hazardous situation which, if not avoided, could result in death or serious injury.</p>
 WARNING	<p>WARNING: Indicates a potentially hazardous situation which, if not avoided, could result in death or serious injury.</p>
 CAUTION	<p>CAUTION: Indicates a potentially hazardous situation which, if not avoided, may result in minor or moderate injury. CAUTION may also be used to alert against unsafe practices associated with events that could lead to personal injury.</p>

	<p> WARNING</p> <p>Always wear proper eye protection when Operating or servicing this equipment.</p> <p>Failure to wear eye protection could result in serious eye injury from flying debris.</p>		<p> WARNING</p> <p>Heavy Object To avoid muscle strain or back injury, use lifting aids and proper lifting techniques when removing or replacing.</p> <p>Failure to observe these precautions may result in injury or property damage.</p>
	<p> WARNING</p> <p>Never wear clothing or jewelry that is loose or That could potentially hang into the equipment and get caught.</p> <p>Failure to observe this warning could result in Severe Injury or death.</p>		<p> WARNING</p> <p>Never install or service this machine while connected to any electrical power source. Disconnect power by unplugging the press from its power source.</p> <p>Failure to observe this warning could result In severe injury or death.</p>
	<p> WARNING</p> <p>Never operate, service, install, or adjust this machine without proper instruction and without first reading and understanding the instructions in this manual and all applicable press and/or wire processing machine manuals.</p>		<p> WARNING</p> <p>Always hand cycle the applicator in the equipment to ensure the tooling is properly aligned.</p> <p>Failure to observe these precautions may result in Injury or property damage.</p>

	 WARNING	 WARNING
	<p>Never use this press or wire processing machine without guards or safety devices that are intended to prevent hands from remaining in the die space.</p> <p>Failure to observe this warning could result in Severe injury or death.</p>	 <p>Do not use compressed air to clean this equipment. The forces created by compressed air can force debris into the tool.</p> <p>Failure to observe these precautions may result in injury or property damage.</p>
	 WARNING Always wear proper ear protection when Operating or servicing this applicator.	
 CAUTION The Molex applicators are designed to operate in presses with standard shut heights of 135.80mm (5.346"). Installation in crimp presses with other than standard shut heights can cause severe tool breakage. It is advisable that before installation, a check of the shut height be performed. Molex will not be liable for any damages as a result of installation in a crimp press with nonstandard or improperly set shut height. Failure to observe these precautions may result in injury or property damage.		
 CAUTION Never perform any service or maintenance other than as described in this manual. Never modify, alter or misuse the equipment Molex crimp specifications are valid only when used with Molex terminals, applicators and tooling. Failure to observe this precaution may result in injury and property damage.		

Tooling Technical Assistance

Molex offers tooling technical assistance for customers who may need some guidance for tooling adjustments. This support can be obtained by calling either of the two numbers listed below and asking for the Molex Tooling Group.
 Call Toll Free 1-800-786-6539 (US) 1-630-969-4550 (Global).

This assistance is limited to the operation and set-up of a customer's Molex Press. Questions with regard to Molex connector products or how to identify the proper tooling and/ or tooling documentation should be directed to your local Molex personnel or Customer Service Representative.

When calling for service on the press a copy of the *Tooling Manual* and Specific *Applicator Tooling Specification Sheet* should be present and a person that is familiar with the applicator should be present. Be sure the following information is supplied:

1. Customer name
2. Customer address
3. Person to contact such as (name, title, e-mail, and telephone number)
4. Applicator order number (Lease number also if applicable)
5. Serial number (Lease number also if applicable)
6. Molex Connector product order number
7. Urgency of request
8. Nature of problem

Molex Application Tooling Group
 2200 Wellington Court
 Lisle, IL 60532, USA
 Tel: +1 (630) 969-4550
 Fax: +1 (630) 505-0049

Visit our Web site at <http://www.molex.com>

Table of Contents

Contents

FineAdjust™ APPLICATOR	1
Order No 63800-4900.....	1
Safety Warnings and Information	2
Table of Contents	4
Section 1	6
General Description	6
Principal Mechanical Parts of the FineAdjust Applicator	7
1.1 Description.....	8
1.2 Features	8
1.3 Technical Specification.....	8
1.4 Delivery Check	8
1.5 Tools.....	9
1.6 Specification Sheets	9
Section 2	10
Set-Up and Operation.....	10
2.1 Shut Height.....	11
2.2 Set-Up	11
2.3 Adjustments.....	13
2.4 Crimp Tooling Installation and Removal	16
Section 3	18
Maintenance	18
3.1 Cleaning	19
3.2 Lubrication	19
3.3 Spare Parts.....	20
3.4 Perishable Parts	20
3.5 Storage.....	21
Section 4	22
Styles of FineAdjust	23
4.1 STYLE A-FineAdjust Applicator.....	24
4.1 STYLE A FineAdjust Applicator Assembly.....	26
4.1 STYLE A FineAdjust Applicator Assembly (Cont.).....	27
4.2 STYLE B-FineAdjust Applicator	28
4.2 STYLE B FineAdjust Applicator Assembly.....	30
4.2 STYLE B FineAdjust Applicator Assembly (Cont.).....	31
4.3 STYLE C-FineAdjust Applicator.....	32
4.3 STYLE C FineAdjust Applicator Assembly	34
4.3 STYLE C FineAdjust Applicator Assembly (Cont.)	35
4.4 Troubleshooting.....	36
Appendix A.....	38
Crimp Terminations	38
A.1 Conductor Brush and Terminal Position	39
A.2 Conductor Bell Mouth and Terminal Cutoff Tab.....	40
A.3 Conductor Height Measurement.....	41
A.4 Insulation Crimp.....	41
A.5 Pull Force Testing.....	43
Appendix B.....	45

Statistical Process Control (Summary) 45
B.1 Crimp Process Control 46
B.2 Process Capability 46
B.3 Production 47
Appendix C 49
Options..... 49
Terminal Oiler **Error! Bookmark not defined.**50
Order No. 63890-0719..... **Error! Bookmark not defined.**50

Section 1

General Description

- 1.1 Description
- 1.2 Features
- 1.3 Technical Specifications
- 1.4 Delivery Check
- 1.5 Crimp Tooling Accessories
- 1.6 Tools
- 1.7 Specification Sheets

Principal Mechanical Parts of the FineAdjust Applicator

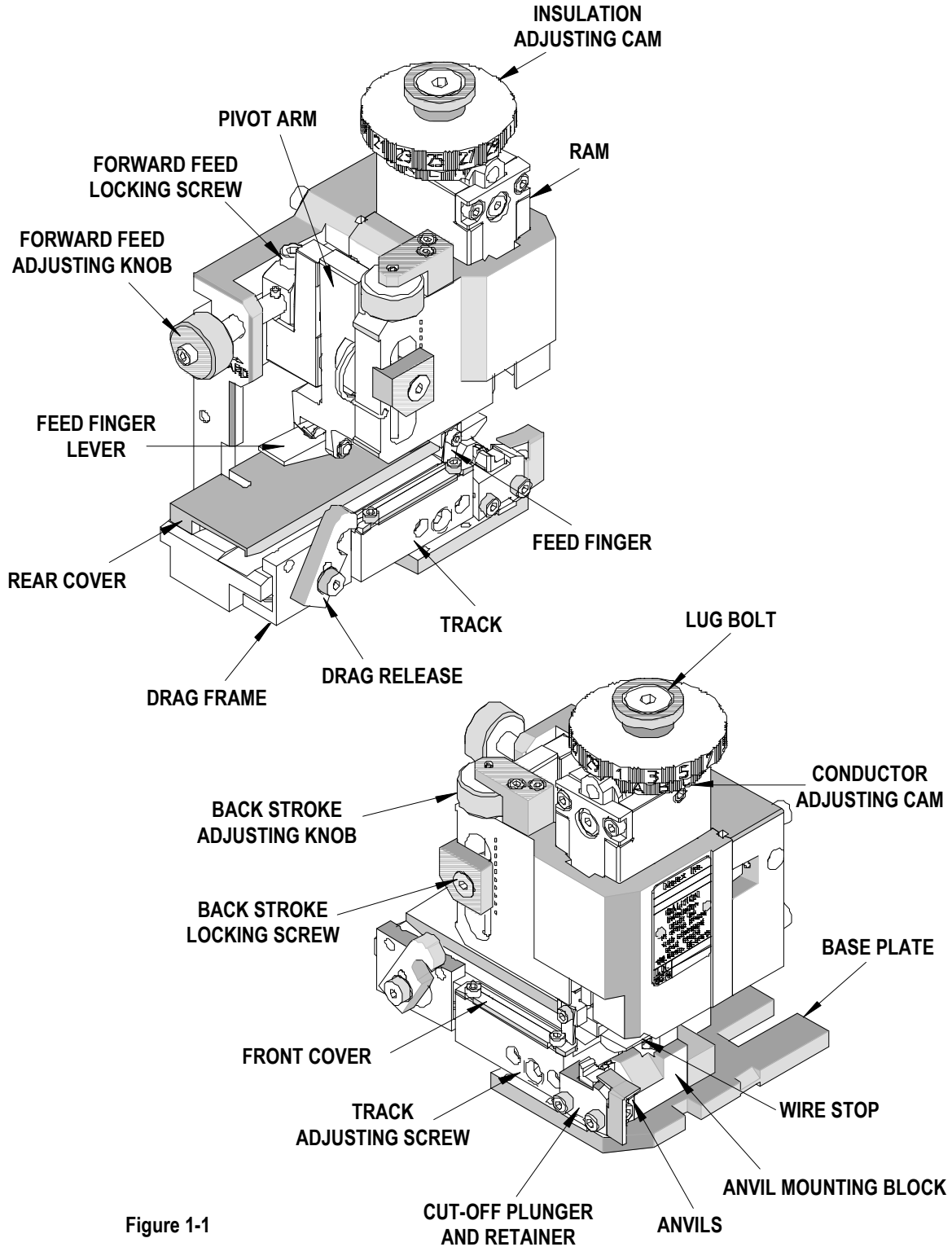

Figure 1-1

General Description

1.1 Description

The Molex FineAdjust™ Applicator is designed to provide an effective method of applying a wide range of side feed terminals to a pre-stripped discrete wire. It is the most advanced version of a "universal" crimping tool available. It is designed to allow for quick adjustments of crimp height, track position, and terminal feed without taking the applicator out of the press and without shimming. This allows easy adjustment of crimp height to the target value with improved process capability, even after a wire change-over.

This applicator works in the Molex TM-2000 and TM-3000 Universal Press and in most industry standard presses. The FineAdjust™ applicator offers minimal setup time without the need for shimming, is versatile, reliable, easy to install, and is designed for mid-volume to high-volume, semi or fully automatic operations.

Molex offers the following crimp presses for operating the Fine Adjust Applicator™:

- ✓ TM-2000 Press 120 V 60 Hz. **63800-8300**
- ✓ TM-2000 Press 240 V 50 Hz. **63800-8400**
- ✓ TM-3000 Press 120 V 60 Hz. **63801-7200**
- ✓ TM-3000 Press 240 V 50 Hz. **63801-7300**
- ✓ TM-4000 Press 240 V 60 Hz. **63801-7600**

The FineAdjust Applicator is also compatible with most OEM presses (Artos, Mecal, Komax, Megomat, Toyojamco, etc). It also adapts to most wire processing machines.

1.2 Features

- Fine adjustment allows users to achieve target with little effort by adjusting in increments (14 settings) of .015mm (.0006") for conductor crimp height and (29 settings) in increments of .063mm (.0025") for insulation height.
- Independent adjustment rings allow users to quickly adjust the conductor or insulation crimp height without affecting each other.
- Quick tooling removal with the push of a button for fast and easy punch change.
- Track adjustment for bell mouth and cut-off tab is adjusted while the applicator is in the press for fast and easy setup.
- Compatible with the Molex TM-2000, TM-3000, TM-4000 Universal Press, and most industry standard presses. However, it does NOT fit into Molex TM-40/42 press.

- Directly adapts to most automatic wire processing machines.
- Quick set-up time; plus the crimp height, track and feed adjustments can be preset in applicator.
- Applicator designed to industry standard mounting and shut height 135.80mm (5.346").
- Automatic terminal feed with applicator in press.
- Adjustable terminal feed with applicator in press.
- Terminals are separated from carrier strip automatically during crimping operation.
- Quiet operation with low maintenance and easy to keep clean.
- The FineAdjust™ available for most Molex brand terminals.

1.3 Technical Specification

Dimensions

Width:	132mm	(5.2")
Depth:	101mm	(4.0")
Height:	152mm	(6.0")

Weight

4.1kg (9lbs)

Press Stroke Compatibility

41.28mm (1 5/8")
28.58mm (1 1/8")

Guarding

The FineAdjust™ Applicator is supplied with no guards and is intended to be used with the guards supplied by the press manufacturer.



Caution: DO NOT use the applicator without guards

1.4 Delivery Check

Carefully remove the FineAdjust Applicator from its shipping container and determine that the following items are included in the package.

FineAdjust Applicator (Tooled for desired terminal)	1
11-18-4238 Short Feed Cam	1
Specification Sheets TM-638004900	1
Operation Manual	1
Sample Crimped Terminals	5
Crimp Tooling Accessories	

63890-0719 Terminal Oiler (Appendix C)
 63800-2800 Digital Crimp Micrometer

The specification sheet should be filed. These are available on the Molex website (www.molex.com).

1.5 Tools

The following tools are recommended for setup and adjustments to the applicator:

1. Metric standard hex wrench set
2. Adjustable wrench
3. Wire stripper / cutter
4. Scissors

1.6 Specification Sheets

Molex ships specification sheets with every applicator. The specification sheet contains the following:

- E Terminal numbers
- E Wire AWG ranges
- E Insulation diameter ranges
- E Strip lengths
- E Pull force
- E Crimp heights
- E Bell mouth
- E Bend, twist, and roll limits
- E Tooling parts list and assembly

Fine Adjust Applicator for MX120G Mat Seal Terminals

FineAdjust Applicator	molex Application Tooling Specification Sheet	 Order No. 63902-6700
-----------------------	---	--------------------------

FEATURES

- Quick punch removal with the push of a button for fast and easy tooling change
- Applicator designed to industry standard mounting and shut height 133.80mm (5.348")
- Quick set-up time; plus the crimp height, track and feed adjustments can be set without removing the applicator from the press.
- Fine adjustment allows users to achieve target with little effort by adjusting in increments of .015mm (.0006") for conductor crimp height and .053mm (.0021") for insulation height
- Independent adjustment rings allow users to quickly adjust the conductor or insulation crimp height without affecting each other
- Directly adapts to most automatic wire processing machines

SCOPE
 Products: MX120G Mat Seal Receptacle Terminals, 0.75mm² wires.

Terminal Series No.	Terminal Order No.	Wire Size		Insulation Diameter		Strip Length (Std.)	
		Wire 1	Wire 2	mm	in.	mm	in.
28299	28299-0001	21-27 AWG	0.25 mm ²	1.60-1.96	0.682-0.75	4.50-5.50	177-217

DEFINITION OF TERMS

Doc No: A1S-639026700 Release Date: 11-19-12 UNCONTROLLED COPY Page 1 of 5
 Revision: A Revision Date: 12-19-12

tapping under power. Check

80 mm (5.348"), Tooling

led with the press or wire's instruction manual

s, applicators and tooling

6-6538

Figure 6

Doc No: A1S-639026700 Release Date: 11-19-12 UNCONTROLLED COPY Page 4 of 5
 Revision: A Revision Date: 12-19-12

Visit our Web site at <http://www.molex.com>

Doc No: A1S-639026700 Release Date: 11-19-12 UNCONTROLLED COPY Page 5 of 5
 Revision: A Revision Date: 12-19-12

Section 2

Set-Up and Operation

- 2.1. Shut Height
- 2.2. Set-Up
- 2.3. Adjustments
- 2.4. Crimp Tooling Installation and Removal



Read the following instructions before attempting to operate the applicators.

2.1 Shut Height

The Molex FineAdjust Applicators are designed to operate in crimp presses with standard shut height of 135.80mm (5.346"). Installation in crimp presses with other than standard shut heights can cause severe tool breakage. It is recommended that before installation, a check of the shut height be performed. The correct shut height is required to prevent the punches from hitting the anvils and the cut-off tooling from bottoming out on the base plate. It also allows the movement of applicators from press to similar press without adjusting the applicator or press shut height.

The shut height of the press can be checked with a shut height gauge, which is calibrated under load to achieve the 135.80mm (5.346") measurement. It is recommended that the shut height be checked monthly. A shut height gauge is available from most press manufacturers.

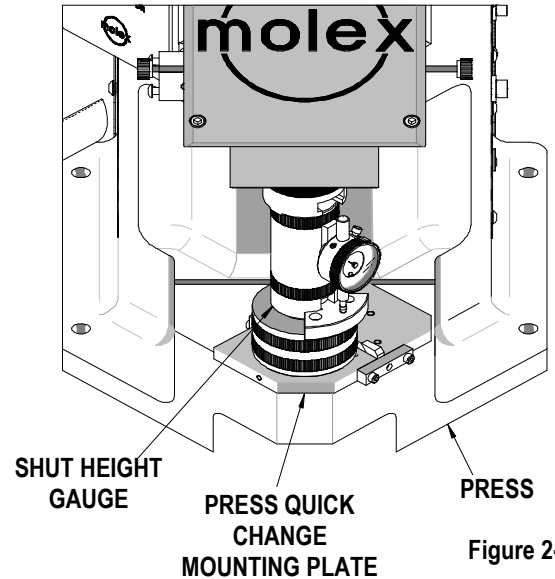

Figure 2-1

Measuring Press Shut Height

1. Always disconnect the power supply from the press. Remove the machine guards if necessary.
2. Remove the applicator from the press. See "Applicator Installation and Removal" (below) for additional information. Make sure that the bottom of the press ram and quick change mounting plate are free from foreign material.
3. Place the shut height gauge into the press on the press quick change mounting plate. See Figure 2-1.
4. Manually cycle the press to the down stroke position. (Follow press manufacturer's instructions on manually cycling the press.)
5. Read the shut height measurement from the front of the gauge. Follow gauge manufacturers' instruction, usually the gauge reads "0" when set correctly.
6. If adjustments are necessary, refer to the press manufacturer for adjustment of the press shut height.
7. Repeat the above steps until the correct shut height is obtained.
8. Shut height gauges must be calibrated on a regular basis.

2.2 Set-Up



IMPORTANT

Power must be shut off and electrical cord disconnected. Manual press cycling is an absolutely required procedure for safety and preventing equipment damage. Always cycle by hand when trouble shooting or changing adjustments, tooling, applicator, or accessories.

The principal mechanical parts of the FineAdjust are illustrated in Section 4.1 Assembly Drawings.

Applicator Installation and Removal

- 1 All presses must be equipped with a common universal type quick-change mounting plate and adapter on the press. Contact the press manufacturer for specific information.
- 2 Always turn off and disconnect the power supply to the press. Remove the press guards.
- 3 Clean the quick change mounting plate of scrap or chips that may interfere with the FineAdjust applicator installation.
- 4 For the TM-2000 and TM-3000 Presses follow the procedure below:
 - a. Using a 4mm hex wrench, turn the M5 SHCS clockwise until the locking clamp is fully opened.
 - b. Visually align the applicator base plate slots with the location clamps on the press quick-change mounting plate.

- c. Slide the applicator onto the quick-change mounting plate until the two notches on the left side engage against the stops, and at the same time, guide the lug bolt into the adapter on the press. See Figure 2-2.
 - d. To lock applicator, turn the M5 SHCS counter clockwise until tight.
- 5 Some presses have locking latches on the quick change mounting plate, which have to be flipped up to secure the applicator. Others have knurled finger screws or "T" type latches. Most of these are located on the right side of the quick change mounting plate to secure the position of the applicator. These must be in place and secured before operating the press.
 - 6 Replace the press guards.

Remove the applicator by reversing the previous steps. When storing an applicator, always leave a strip of terminals in the applicator to prevent damage to the tooling. See Section 3.5 Storage.

Fitting Terminal Strip

1. The specified terminals are printed on the setup sheet for the applicator. Only use the Molex terminals on the setup sheet which is supplied with the applicator.
2. Always disconnect the power supply from the press. Remove the machine guards if necessary.
3. Rotate the drag release until the drag frame is in the upright position. This will allow the terminal to slide with ease through the applicator track. See Figure 2-3.
4. Push the terminal strip until the first terminal comes to rest centered above the anvil.
5. Rotate the drag release to engage the terminal drag frame.
6. Cycle the press by hand so that the feed finger transfers the next terminal to a centered position over the anvil. Check that all other parts slide and engage without any interference. It is recommended to go through this procedure several times.

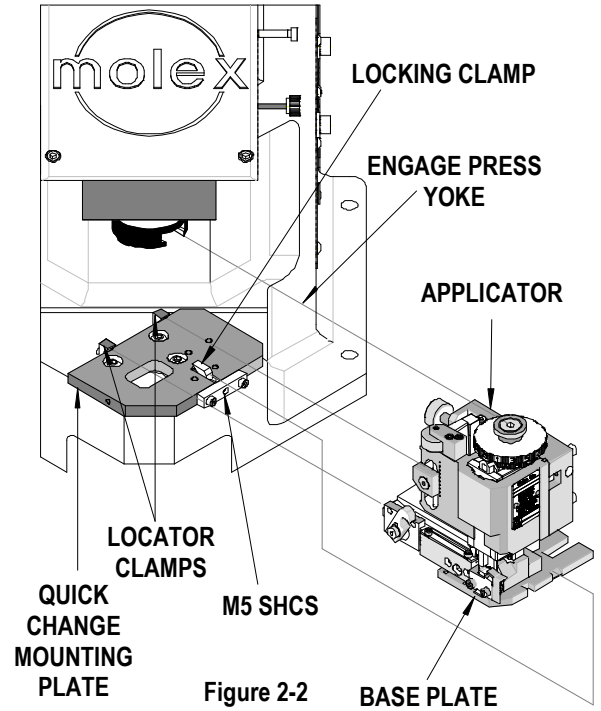

Figure 2-2

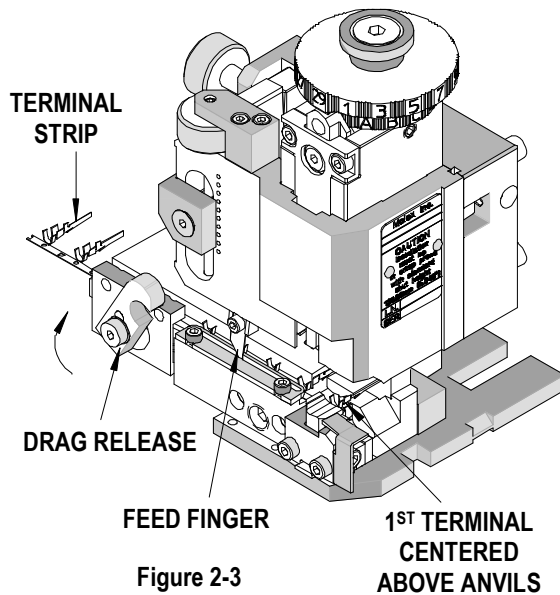

Figure 2-3

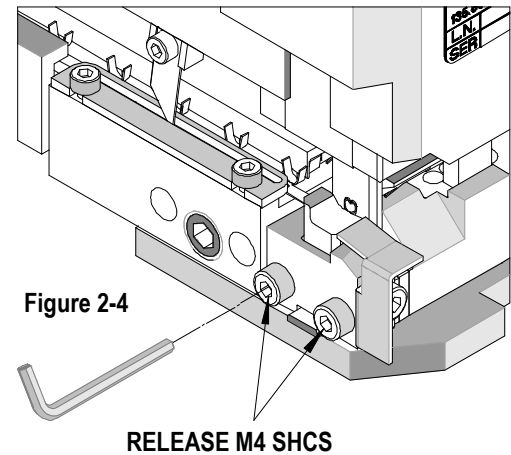

Figure 2-4

7. When unloading the terminal strip, make sure the power is turned off and disconnected from the press. Remove the machine guards if necessary.
8. Rotate the drag release until the drag frame is in the upright position.
9. Raise feed finger and pull terminal strip back until disengaged from applicator track. See Figure 2-3. If preferred, cut the terminal carrier strip and pull it through the applicator with needle nose pliers.
10. Replace the machine guards before operating the press.

Punch and Anvil Alignments

Note: Always clean mounting surfaces of crimp tooling and tooling holders before alignment.

1. Always disconnect the power supply from the press. Remove the machine guards if necessary.
2. With a terminal in position over the anvils, slightly release anvil mounting screw. See Figure 2-4.
3. Gently hand-cycle the ram of the press to bottom of its stroke. Tighten anvil-mounting screws in this position to ensure perfect alignment of punches and anvils.
4. Hand cycle the press ram to the highest position.
5. Replace the machine guards before operating the press.

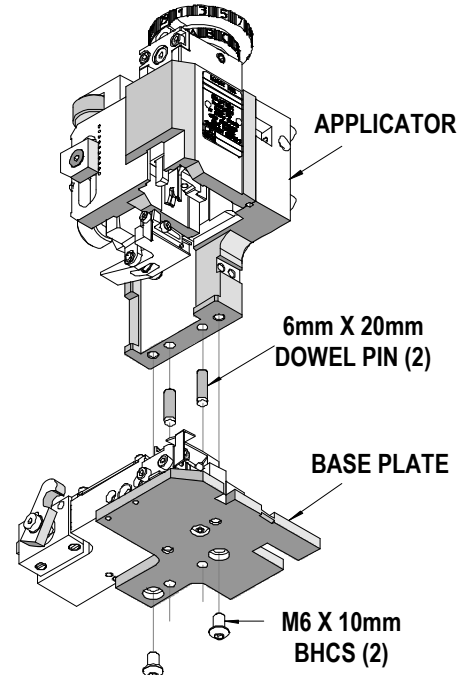

Figure 2-5

2.3. Adjustments

Cover Plate Adjustments

1. Always disconnect the power supply from the press. Remove the machine guards if necessary.
2. Remove the applicator from the press. Refer to Applicator Installation and Removal.
3. Rotate the drag release until the drag frame is in the upright position. The rear cover plate should be adjusted so that the terminal strip will slide smoothly through the track with no resistance.
4. Some applicators require the removal of the applicator frame from the base plate. This is done by removing the two M6 BHCS located on the bottom of the base plate. See Figure 2-5.
5. Loosen the two M4 BHCS to adjust the position of the rear cover. See Figure 2-6.
6. Slide terminal strip through the track to ensure accurate cover positioning.
7. After the correct position is achieved, tighten the two M4 BHCS.
8. Reattach the applicator frame to the base plate if needed. Locate the position of the frame using the dowel pins. Tighten the two M6 BHCS to secure the frame to the base plate.

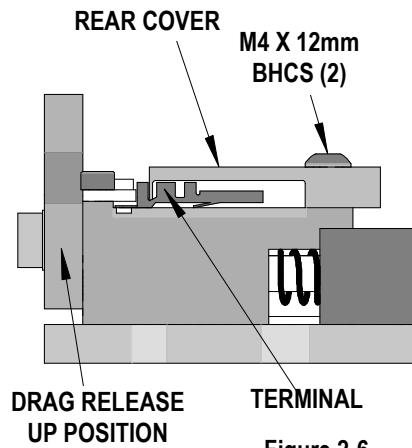

Figure 2-6

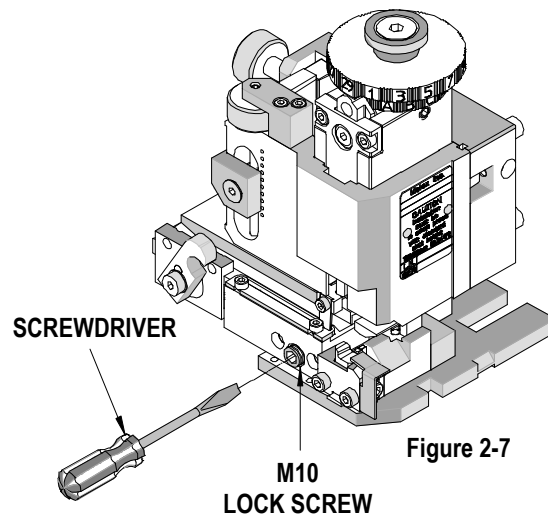

Figure 2-7

Track Position Adjustment

1. Disconnect power from the press. Remove the machine guards if necessary.
2. To position the terminal track in or out, first use a 6mm hex wrench to loosen the M10 lock screw located on the front of the track.

3. Put a regular screwdriver through the hole in the lock screw and turn the adjusting screw to position the terminal in the correct location. See Figure 2-7. Turning the screw clockwise will move the track towards the operator; to move the track towards the applicator turn the screw counterclockwise. Depending on the amount of movement, the feed finger mount may need to be loosened and readjusted. See Feed Finger adjustment.
- 7 To lock the track in position, tighten the M10 lock screw.
- 8 If the feed finger mount was loosened during the track positioning, remember to tighten its mounting screw.
- 9 Replace machine guards.
- 10 Hand cycle the press to ensure the terminal is positioned properly on the anvils and does not have an excessive cutoff tab. Also, verify the terminal feed operation.
- 11 Restore power to the press, crimp a terminal under power, and observe the quality of the termination.
- 12 Repeat the above steps until the desired terminal position is obtained.

Feed Finger Adjustments

1. Position the feed finger to properly feed the next terminal in position. Typically, terminals are fed by the carrier strip.
2. Depending on the feed cam installation (pre-feed or post-feed), move the press ram until the feed is forward (this makes the feed finger mount more accessible), and then disconnect power from the press. Remove the machine guards if necessary.
3. Using a 2.5mm hex wrench, loosen the M3 SHCS located on the feed finger mount. While holding the feed finger lever down slightly, slide the feed finger to the desired position. See Figure 2-8.
4. If the feed finger mount cannot be moved far enough, remove the M3 SHCS completely and install it in another tapped hole in the feed finger lever. In addition, the feed finger mount can be reversed (the feed finger must be reversed as well) to gain additional adjustment.
5. Tighten the M3 SHCS to lock the feed finger in position.

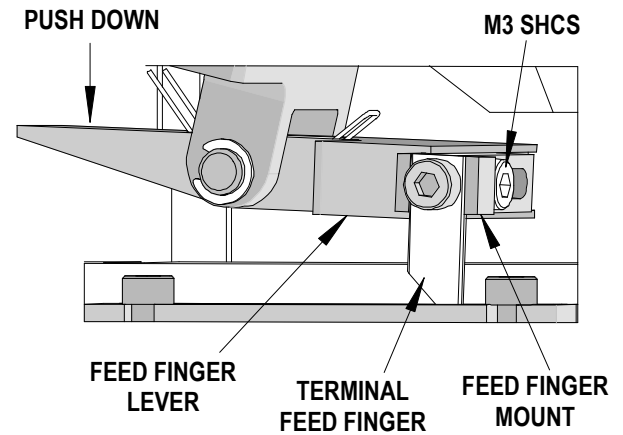

Figure 2-8

Feed Stroke Cam Adjustments

1. The terminal feed stroke is driven by a cam mounted to the applicator ram. Two feed cams are shipped with the applicator. The standard cam is installed in the applicator. The spare cam is for presses with short strokes (for example, 28mm). Using the standard cam with a short-stroke press may result in insufficient feed stroke or incorrect feed timing.
2. Determine what feed timing is desired. Typically, when the applicator is mounted in a wire processing machine, the feed stroke cam should be assembled in the down stroke position. While the press is idle in the up position, a terminal will not be present over the anvil. For most bench applications, the cam is installed in the up stroke position. This will leave a terminal over the anvil when the press is idle in the up position. See Figure 2-9.
3. Turn off and disconnect the power supply from the press. Remove the machine guards if necessary.
4. Remove the applicator from the press. See Applicator Installation and Removal.
5. Pull back on the feed pivot lever and remove the ram from the applicator.
6. Holding on to the ram, use a 3mm hex wrench to remove the M4 SHCS holding the cam on the back of the ram.
7. Position the cam in the desired position for feeding and attach with the M4 screw. See Figure 2-9.

Feed Cam Order No.	Press Stroke		Feed Timing
	mm	In.	
 63800-0305	41.28	1-5/8	Up stroke (terminal present over anvil)
	28.58	1-1/8	
 63800-0305	41.28	1-5/8	Down stroke (terminal not present over anvil)
 11-18-4238	28.58	1-1/8	Down stroke (terminal not present over anvil)

Figure 2-9

Forward Feed Adjustments

1. The forward feed position must locate the terminal that is being crimped exactly over the anvils.
2. Disconnect the power from the press. Remove the machine guards if necessary.
3. Make sure there is a terminal over the anvils and the feed finger is fully forward (closest to the anvils).
4. Loosen the M5 SHCS.
5. Turn the forward feed adjusting knob to position the terminal. To decrease the feed position, turn the forward feed adjusting knob clockwise. To increase the feed position turn the forward feed adjusting knob counterclockwise. See Figure 2-10.
6. When adjusting to decrease the feed position, it is necessary to pull the terminal strip backwards until it is against the feed finger. When increasing the feed position, the feed finger will push the terminal farther over the anvils.
7. After properly adjusting the forward feed position of the terminal, tighten the M5 SHCS with a 4mm hex wrench.

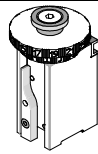
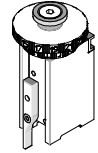
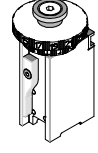
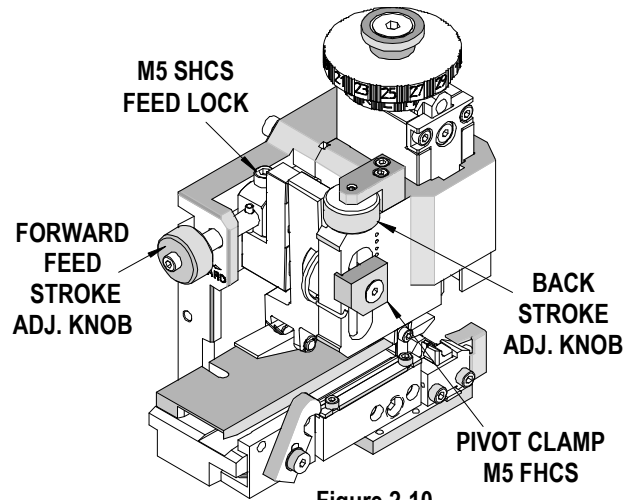

Figure 2-10

Back Stroke Feed Adjustments

1. To properly feed the terminal strip, the back feed stroke should have enough over-travel to pick up the next terminal. Too much over travel may, in some cases, cause a double-feed.
2. Disconnect the power from the press. Remove the machine guards if necessary.
3. To achieve the correct backstroke location, adjust the position of the hinge bushing. First, use a 3mm hex wrench to loosen the M5 FHCS holding the pivot clamp. Turning the backstroke adjustment knob (which is located above the hinge bushing) clockwise will raise the hinge bushing and will increase the backstroke. Turning the knob counter clockwise (CCW) will lower the hinge bushing and will decrease the feed backstroke. When adjustment is complete, tighten the pivot clamp securely. See Figure 2-10.
4. Since back feed stroke adjustment may not be visibly obvious, the terminal feed should be cycled (by hand, if possible) to observe the changes.
5. Back feed stroke adjustments may affect the entire feed linkage; re-adjustment of the forward feed stroke could be necessary. See Forward Feed Adjustments.

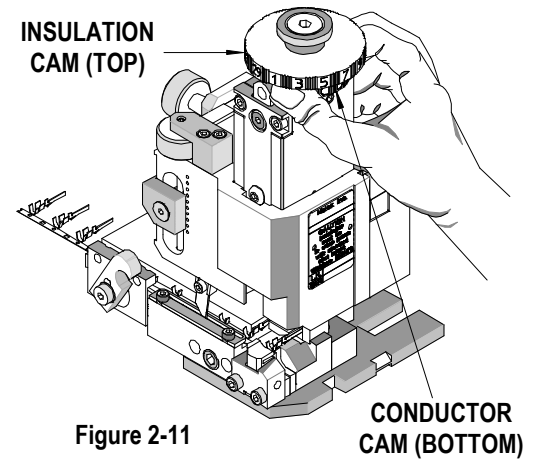

Figure 2-11

Conductor Crimp Punch Adjustments

1. With the guards intact, place a stripped length of suitable wire into the terminal and terminate the wire under power.
2. Inspect the quality of conductor crimp and measure the crimp height. See Appendix A.3 Conductor Crimp Height Measurement.
3. If adjustments are necessary, turn off and disconnect the power supply from the press. Remove the machine guards.
4. The desired crimp height can be achieved by rotating the conductor-adjusting cam. See Figure 2-11. Each increment represents approximately 0.015mm (.0006") for a total adjustment of 1.80mm (.071"). The "A" setting is the loosest crimp height and the "N" setting is the tightest. If you find that the crimp height is not acceptable, you can rotate the adjusting cam until the desired crimp height is obtained. See Section 2.1, Shut Height. No shimming of the applicator is required.
5. Replace the machine guards and repeat the previous steps until the desired crimp height is obtained. See Appendix A.3, Conductor Crimp Height Measurement.
6. Perform a pull test on conductor crimp to verify the mechanical integrity of the crimp. See Appendix A.5, Pull Force Test.

Insulation Crimp Punch Adjustment

1. Place a stripped length of the appropriate wire into the terminal and crimp under power.
2. Observe quality of insulation crimp and measure the crimp height. See Appendix A.4, Insulation Crimp.
3. If adjustments are necessary, always turn off and disconnect the power supply from the press. Remove the machine guards.
4. Rotate the insulation-adjusting cam to achieve the desired insulation height. Each increment represents approximately 0.06mm (.0025") for a total adjustment of 3.00mm (.118"). The "1" setting is for the highest (most loose) crimp height and the "29" setting the lowest (most tight) crimp height.
5. Repeat the previous steps until the desired insulation height is obtained.

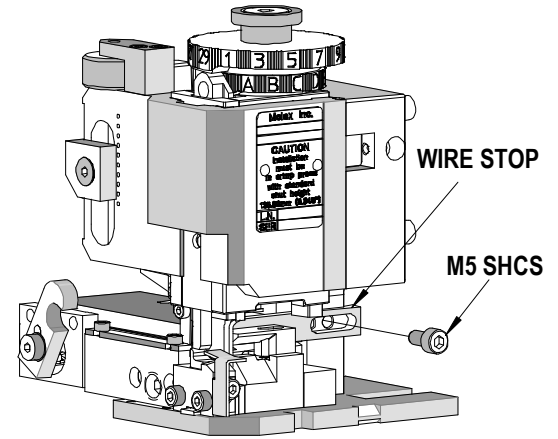

Figure 2-12

Note: Due to the large variety of insulation wall thickness, materials, and diameter, Molex does not specify insulation crimp height. For each different wire type, the insulation crimp height can be measured, recorded, and inspected as a quality indicator.

Wire Stop Adjustment

For automatic wire processing machines, the wire stop can be used to assist in the stripping of the terminal from the punches. However, in certain circumstances the wire stop will need to be removed when running on an automated machine.

1. Check the setup documents to obtain the correct strip length.
2. Place the correct wire into the terminal and crimp the wire under power.
3. Observe quality of crimp and the wire position. See Appendix A.1 Conductor Brush and Terminal Position.
4. If adjustments are necessary, turn off and disconnect the power supply from the press. Remove the machine guards.
5. Use a 4mm hex wrench to loosen the M5 SHCS located on the side of the frame. See Figure 2-12.
6. Adjust the position of the wire stop by moving the wire stop, towards the operator decreases the brush length and towards the press increases it.
7. Tighten the M5 SHCS.
8. Hand cycle the press to ensure the applicator is functioning properly. Then crimp a terminal under power and observe the quality of the termination.

2.4 Crimp Tooling Installation and Removal

Installation and Removal of the Upper Tooling (Punches)



Caution: Always disconnect power supply before installing or removing tooling.

NOTE: Always clean mounting surfaces of crimp tooling and tooling holders before installation.

1. Always turn off and disconnect the power supply from the press. Remove the machine guards if necessary.
2. Remove the applicator from the press. See Section 2.2, Applicator Installation and Removal.
3. Pull back the feed arm and remove the ram from the applicator.
4. With a small screw driver, push in the punch release button located on the front of the ram. See Figure 2-13.
5. Pull the punches out the bottom of the ram.
6. Reverse the previous steps to reinstall the punches.

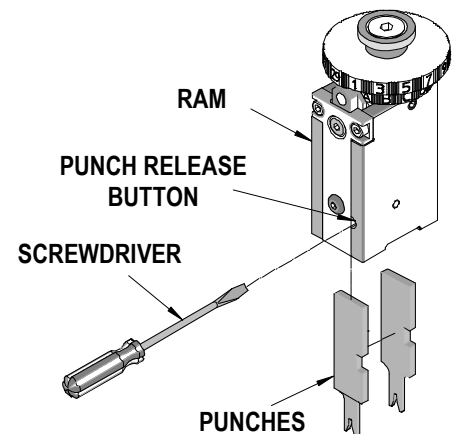

Figure 2-13

Installation and Removal of the Lower Tooling (Anvils)



Caution: Always disconnect power supply before installing or removing tooling.

NOTE: Always clean mounting surfaces of crimp tooling and tooling holders before installation.

1. Always turn off and disconnect the power supply from the press. Remove the machine guards if necessary.
2. Make sure the ram is all the way in the up position.
3. Remove the M4 SHCS that are holding the lower tooling in place and pull out the tooling. See Figure 2-14.
4. Put in the new anvils, leaving the mounting screws loose. For tightening, see Section 2.2, Punch and Anvil Alignment.

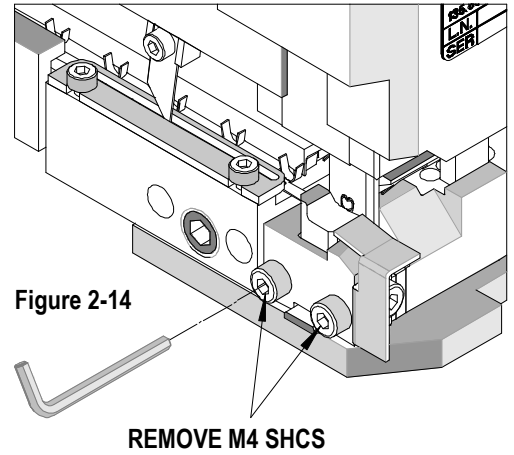

Section 3

Maintenance

- 3.1 Cleaning
- 3.2 Lubrication
- 3.3 Spare parts
- 3.4 Perishable Parts
- 3.5 Storage

3.1 Cleaning



Caution: Always disconnect power supply before installing or removing tooling.

For efficient operation, the FineAdjust Applicator should be cleaned daily. Use a soft bristle brush to remove debris from critical areas such as the crimp tooling. For best results, remove the crimp tooling from the press. Brush and then use a clean cloth to wipe off the upper and lower tooling mounting areas. Before reinstalling tooling, wipe all sides of the punches and anvils with a clean cloth.

3.2 Lubrication



WARNING: Disconnect electrical power before all maintenance.

1. Grease the ram including the cam.
2. Oil the feed finger assembly and all moving parts.
3. Lubricate with multipurpose synthetic lubricant with Teflon or an equivalent. Molex ships its applicators pre-greased with Permatex multi-purpose synthetic grease with Teflon No. 82329. A SAE 30WT non-detergent oil or light spindle oil or 3-n-1 oil should be used on pivot points.



WARNING: Never use penetrants such as WD40 for any lubrication on the machine.

4. Lubricate all points shown in Figures 3-1 with the specified oil and grease (or equivalent).

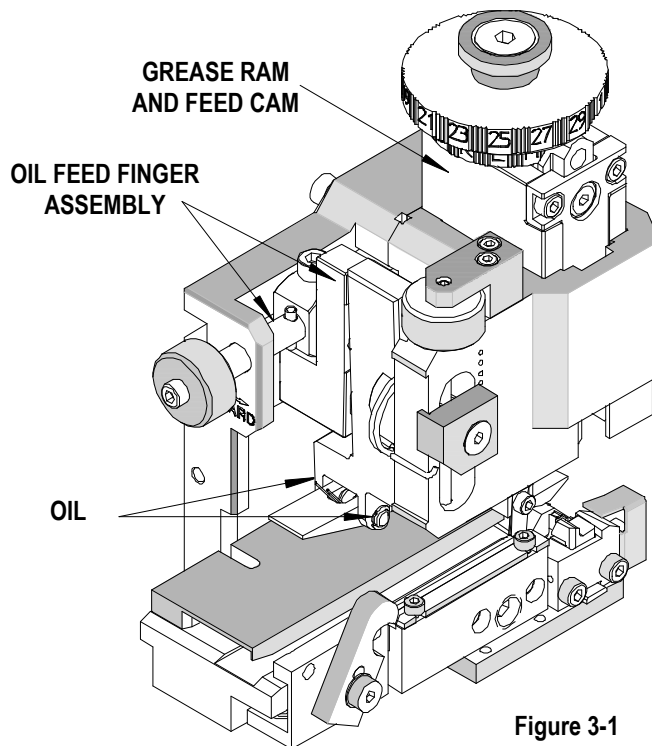

Figure 3-1

An example of a maintenance chart is shown below. Copy and use this chart to track the maintenance of your FineAdjust Applicator or use this as a template to create you own schedule or use your company's standard chart, if applicable.

Preventive Maintenance Chart

Daily: Clean. See Section 3.1.

As Required: Lubricate. See Section 3.2.

CHECK SHEET MONTH _____ YEAR _____

Week	Daily Cycles	Daily Clean	Days of the Week							Solution
			MON	TUE	WED	THU	FRI	SAT	SUN	
1										
2										
3										
4										
Cleaning Reapply grease Reapply oil	25,000	Yes								Soft Brush Industrial Degreaser
Inspect all tooling, feed fingers etc. for wear	25,000	Yes								Replace if signs of wear.

Schedule should be adjusted up or down depending on usage. Molex recommends that a log of preventive maintenance be kept with the press.

3.3 Spare Parts

Customers are responsible for maintaining the FineAdjust Applicator. Spare parts are available. Moving and functioning parts can be damaged or wear out over time and will require replacement. Molex recommends that the customer keep some or all of them in stock to reduce production down time.

3.4 Perishable Parts

Customers are responsible for maintaining the FineAdjust Applicator. Perishable parts are those parts that come in contact with the product and will wear out over time. Molex recommends that all customers keep at least one set of the perishable tool kits in stock at all times. This will reduce the amount of production down time. **For the proper perishable tool kit information, refer to the Crimp Tooling Specification Sheet supplied with the Applicator.**

Tooling Replacement Schedule

The following is offered as a general guideline for tooling replacement. The manufacturer should monitor the process and collect data on actual frequency as tool wear varies on different terminal materials and tool life can be increased with good maintenance practices or decrease with lack of maintenance.

Items	Cycles Brass Alloys	Cycles Steel	Actual
Punches	300,000/500,000	200,000/400,000	
Anvils	500,000/750,000	400,000/750,000	
Cut-off Plungers	300,000/500,000	200,000/400,000	
Feed Fingers	300,000/900,000	300,000/900,000	
Cut-off Punches	500,000/750,000	200,000/400,000	
Cut-off Blades	300,000/500,000	200,000/300,000	

Judgment on tool replacement should be based on the attributes of the crimp they produce.

See the following chart for common signs of wear.

Punches	On Terminal	Notes
Scoring	Uneven Curls	Replace
Tip Loss	Open seam	Replace
Anvils		
Rounded Edges	Large Extrusion	Replace
Chipping	Burrs-On Tabs	Replace
Worn Cut Edges	Burrs	Replace
Cut-Off Plungers and Punches		
Chipped or Rounded	Burr on Tab	Replace
Cut Edge	Burr on Tab	Replace
Cut-off Dies	Burrs on Cut Area	Replace

3.5 Storage

To prevent the bottoming of the ram, which can cause damage to the crimp punches and anvils leave a strip of terminals in the applicator or place a piece of wood or rubber between the punches and the anvils.

Section 4

Parts Lists, Assembly Drawings and Troubleshooting

- 4.1 Style A FineAdjust Applicator
- 4.2 Style B FineAdjust Applicator
- 4.3 Style C FineAdjust Applicator
- 4.4 Troubleshooting

Styles of FineAdjust

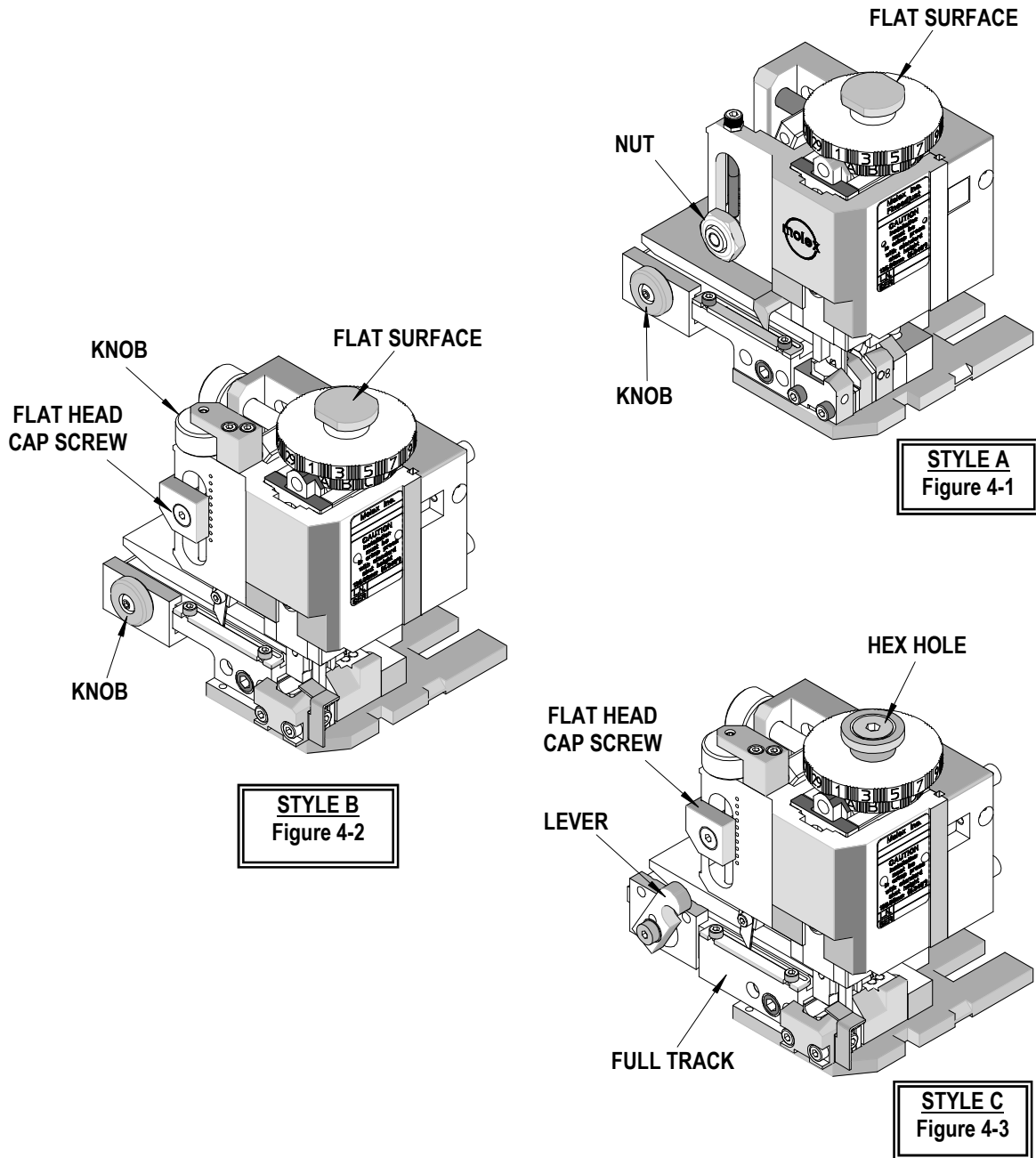

In the effort to continually improve the FineAdjust Applicator, we have multiple styles working in the field. To determine the style of applicator you are using, look at the pictures above. Figure 4-1, 4-2, and 4-3 point out the major differences between the styles of this applicator. Identify your applicator style and use the appropriate parts list and assembly drawing to order replacement parts.

4.1 STYLE A-FineAdjust Applicator

Parts List and Assembly Drawings (See Figure 4-4 and 4-5)

STYLE A-FineAdjust Applicator				
Item	Order No.	Engineering No.	Description	Qty
1	11-18-4238	60700-1	Feed Cam (Short) Optional	1
2	11-32-5346	60000Y422	M4 Ball Spring Plunger	4
3	11-41-0127	60678-27	Compression Spring (Associated # C0180-016-0500)	1
4	63600-0481	63600-0481	Shoulder Screw M5 by 10mm Long	1
5	63800-0115	63800-0115	Spacer Tube	1
6	63800-0117	63800-0117	Feed Pawl Lever	1
7	63800-0118	63800-0118	Hinge Bushing	1
8	63800-0119	63800-0119	Feed Finger	1
9	63800-0120	63800-0120	Feed Arm	1
10	63800-0121	63800-0121	Lever Feed Pivot	1
11	63800-0122	63800-0122	Feed Adjusting Screw	1
12	63800-0123	63800-0123	Slider-Feed Cam	1
13	63800-0124	63800-0124	Pin-Feed Adjusting	1
14	63800-0125	63800-0125	Torsion Spring-Hinge	1
15	63800-0127	63800-0127	Torsion Spring-Feed Pawl	1
16	63800-0129	63800-0129	Washer -3.40mm Thick	1
17	63800-0140	63800-0140	Cylinder Pin	1
18	63800-0141	63800-0141	Slider	1
19	63800-0142	63800-0142	Roller-Cam Follower	1
20	63800-0143	63800-0143	Pin-Cam Follower	1
21	63800-0144	63800-0144	Key Stock 3mm by 3mm by 29mm Long	2
22	63800-0301	63800-0301	Back Frame	1
23	63800-0302	63800-0302	Face Plate	1
24	63800-0303	63800-0303	Base Plate	1
25	63800-0304	63800-0304	Ram-Terminator Tooling	1
26	63800-0305	63800-0305	Feed Cam	1
27	63800-4906	63800-4906	Insulation Striker	1
28	63800-0308	63800-0308	Terminal Track	1
29	63800-4309	63800-4309	Rear Support Block	1
30	63800-0310	63800-0310	Adjusting Screw	1
31	63800-0311	63800-0311	Locking Screw	1
32	63800-0312	63800-0312	Drag Frame	1
33	63800-0313	63800-0313	Drag Cam	1
34	63800-0314	63800-0314	Retaining Bar	1
35	63800-0316	63800-0316	Guide Pin-Drag Frame	2
36	63800-0330	63800-0330	Lug Bolt	1
37	63800-0331	63800-0331	Conductor Adjusting Cam	1
38	63800-0332	63800-0332	Insulation Adjusting Cam	1
39	63800-0335	63800-0335	Serial Tag	1
40	63800-0345	63800-0345	Retaining Plate	1
41	63800-4946	63800-4946	Conductor Striker	1
42	63800-0347	63800-0347	Retaining Rod	1
43	63800-0348	63800-0348	Detent Spacer	1
44	N/A	N/A	Compression Spring (Lee Spring # LC-032E-0MW)	4**
45	N/A	N/A	Extension Spring (Lee Spring #LE-041C-9)	1**
46	N/A	N/A	Snap Ring 3.2mm ID by 7mm OD by .62mm Thick	2**
47	N/A	N/A	Washer .512" ID by 1.125" OD by 0.15" Thick	1**
48	N/A	N/A	Washer .512" ID by 1.125" OD by 0.18" Thick	1**

STYLE A-FineAdjust Applicator				
Item	Order No.	Engineering No.	Description	Qty
49	N/A	N/A	M3 by 6mm Long FHCS	2**
50	N/A	N/A	M4 Hex Nut	1**
51	N/A	N/A	M4 by 8mm Long BHCS	1**
52	N/A	N/A	M4 by 8mm Long SHCS	3**
53	N/A	N/A	M4 by 10mm Long Set Screw	1**
54	N/A	N/A	M4 by 12mm Long BHCS	2**
55	N/A	N/A	M4 by 45mm Long SHCS	1**
56	N/A	N/A	M5 by 6mm Long BHCS	1**
57	N/A	N/A	M5 by 10mm Long SHCS	1**
58	N/A	N/A	M5 by 35mm Long SHCS	4**
59	N/A	N/A	M6 by 10mm Long BHCS	2**
60	N/A	N/A	M6 by 8mm Long Set Screw	1**
61	N/A	N/A	M12 Self Locking Hex Nut	1**
62	N/A	N/A	3mm by 12mm Long Roll Pin	2**
63	N/A	N/A	5mm by 20mm Long Dowel Pin	1**
64	N/A	N/A	5mm by 25mm Long Dowel Pin	1**
65	N/A	N/A	6mm by 10mm Long Dowel Pin	1**
66	N/A	N/A	6mm by 12mm Long Dowel Pin	2**
67	N/A	N/A	6mm by 20mm Long Dowel Pin	1**
68	N/A	N/A	6mm by 45mm Long Dowel Pin	2**
69	N/A	N/A	#2 (.098 Dia.) by .125 in. Long Drive Screw	2**
** Available from an industrial supply company such as MSC (1-800-645-7270).				

Check Applicator Number Tag or Part Number on part when ordering.