



Chipsmall Limited consists of a professional team with an average of over 10 year of expertise in the distribution of electronic components. Based in Hongkong, we have already established firm and mutual-benefit business relationships with customers from,Europe,America and south Asia,supplying obsolete and hard-to-find components to meet their specific needs.

With the principle of “Quality Parts,Customers Priority,Honest Operation,and Considerate Service”,our business mainly focus on the distribution of electronic components. Line cards we deal with include Microchip,ALPS,ROHM,Xilinx,Pulse,ON,Everlight and Freescale. Main products comprise IC,Modules,Potentiometer,IC Socket,Relay,Connector.Our parts cover such applications as commercial,industrial, and automotives areas.

We are looking forward to setting up business relationship with you and hope to provide you with the best service and solution. Let us make a better world for our industry!



Contact us

Tel: +86-755-8981 8866 Fax: +86-755-8427 6832

Email & Skype: info@chipsmall.com Web: www.chipsmall.com

Address: A1208, Overseas Decoration Building, #122 Zhenhua RD., Futian, Shenzhen, China



PLEASE CHECK WWW.MOLEX.COM FOR LATEST PART INFORMATION

Part Number: [63802-5100](#)
Status: **Active**
Description: Mini-Mac Applicator for Terminals

Documents:
[RoHS Certificate of Compliance \(PDF\)](#)

General

Product Family	Application Tooling
Series	T1101
Comments	See Tooling Specification (PDF) Above
Function	Crimp
Geographic Area	Global
Level of Automation	Automatic, Semi-Automatic
More Detailed Tech Information	applicationtooling@molex.com
Product Name	Mini-Mac™
Survey	www.molex.com//review/apptool_survey.html
Tool Type	Mini-Mac Applicator
UPC	883906757809

Physical

Net Weight 3740.617/g

Material Info

Reference - Drawing Numbers

Application Tooling Documents

ATS-638025100, TM-638000100, TM-638000100SP, TM-638004900, TM-638004900CN, TM-638004900SP, TM-640160065, TM-640160065CN, TM-640160065DE, TM-640160065FR, TM-640160065IT, TM-640160065JP, TM-640160065KR, TM-640160065MY, TM-640160065PL, TM-640160065RU, TM-640160065SK, TM-640160065SP, TM-640160065TH, TM-640160065TW, TM-640160065VN

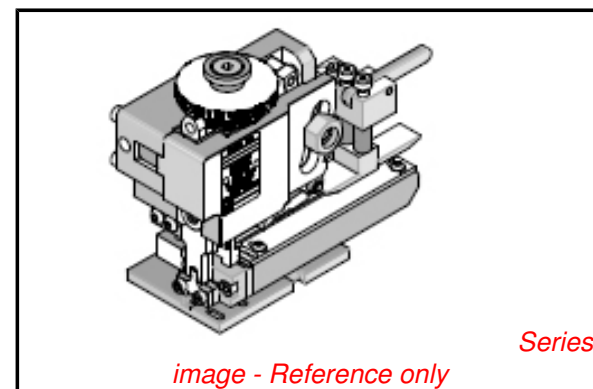

image - Reference only

EU RoHS

ELV and RoHS Compliant

REACH SVHC

Not Reviewed

Low-Halogen Status

Not Reviewed

China RoHS



Need more information on product environmental compliance?

Email productcompliance@molex.com
 For a multiple part number RoHS Certificate of Compliance, [click here](#)

Please visit the [Contact Us](#) section for any non-product compliance questions.

Search Parts in this Series

T1101Series

Use With

35072 MP-Lock™ Quick Disconnect, Female, for 18-22 AWG

Application Tooling | FAQ

Description	Product #
MP-Lock™ Quick Disconnect, Female, for 18-22 AWG (0.80-0.33mm ²), Metal Strip, Tab 6.35 x 0.80mm, Pre-Tin Plated	0350729702
MP-Lock™ Quick Disconnect, Female, for 18-22 AWG (0.80-0.33mm ²), Metal Strip, Tab 6.35 x 1.00mm, Pre-Tin Plated	0350729712

This document was generated on 03/08/2013

PLEASE CHECK WWW.MOLEX.COM FOR LATEST PART INFORMATION