



Chipsmall Limited consists of a professional team with an average of over 10 year of expertise in the distribution of electronic components. Based in Hongkong, we have already established firm and mutual-benefit business relationships with customers from,Europe,America and south Asia,supplying obsolete and hard-to-find components to meet their specific needs.

With the principle of “Quality Parts,Customers Priority,Honest Operation,and Considerate Service”,our business mainly focus on the distribution of electronic components. Line cards we deal with include Microchip,ALPS,ROHM,Xilinx,Pulse,ON,Everlight and Freescale. Main products comprise IC,Modules,Potentiometer,IC Socket,Relay,Connector.Our parts cover such applications as commercial,industrial, and automotives areas.

We are looking forward to setting up business relationship with you and hope to provide you with the best service and solution. Let us make a better world for our industry!



## Contact us

Tel: +86-755-8981 8866 Fax: +86-755-8427 6832

Email & Skype: [info@chipsmall.com](mailto:info@chipsmall.com) Web: [www.chipsmall.com](http://www.chipsmall.com)

Address: A1208, Overseas Decoration Building, #122 Zhenhua RD., Futian, Shenzhen, China





## Module Card Extractor Tool Instruction Manual Part No. 63813-2100

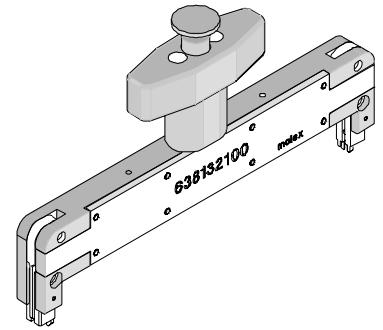

### FEATURES

- This tool is designed for the removal of the memory module card from the metal latch 87814 series Molex sockets, 1 mm pitch, 276-circuit vertical press-fit with metal latch DDR2.

### SCOPE

Products: 87814 Series 276 Circuit Vertical Press-fit Metal Latch DDR2 Dimm Connector System. See Product List below for specific part numbers.

### Product List

The following is a partial list of the product order numbers and their specifications this tool is designed to run. Updates to this list are available on [www.molex.com](http://www.molex.com).

Assembly Order Number	Description
87814-1001	1.00mm (.039") Pitch DDR-2 DIMM Socket, Vertical, Press-fit, 276 Circuits Metal Latch
87814-1002	

### DESCRIPTION

The 1 mm pitch, 276-circuit vertical press-fit with metal latch DDR2 takes up a much smaller space inside the housing than a conventional latch will. The entire connector length is almost similar to the module card. However, the latch cannot be extracted by hand and this extraction tool is required to withdraw the module card from the metal latch.

The Module Card Extractor Tool consists of modular card latch, metal latch, and thumb pusher with a handle.

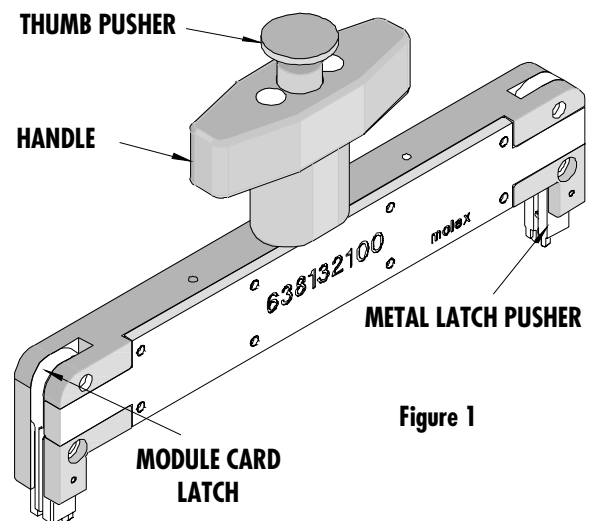

Figure 1

### Operation

1. Align the metal latch pushers (2) with the slots on the module card housing. See Figure 2.
2. Push the extractor tool down and into the slots. The module card latches are spring-loaded and will open when extractor tool is engaged in the module card housing. See Figure 3.

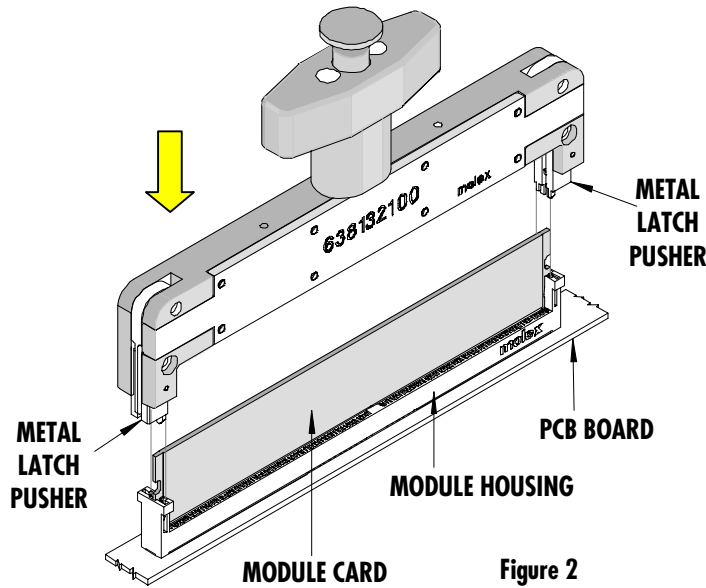

Figure 2

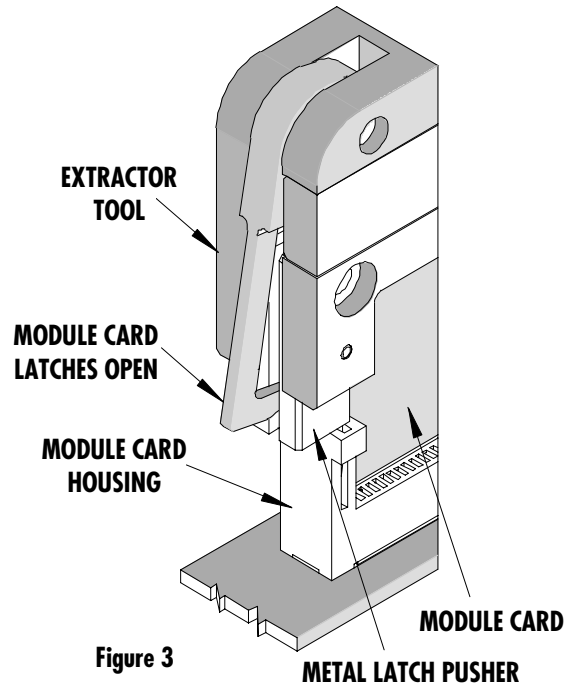

Figure 3

3. Make sure the extractor tool is firmly seated in the slots of the module card housing and the module card latches are locked into the module card.

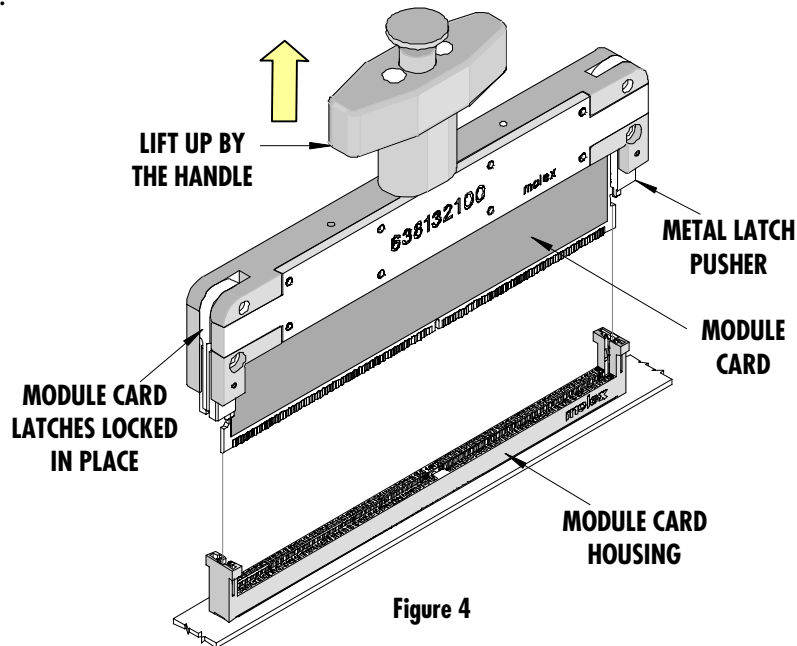
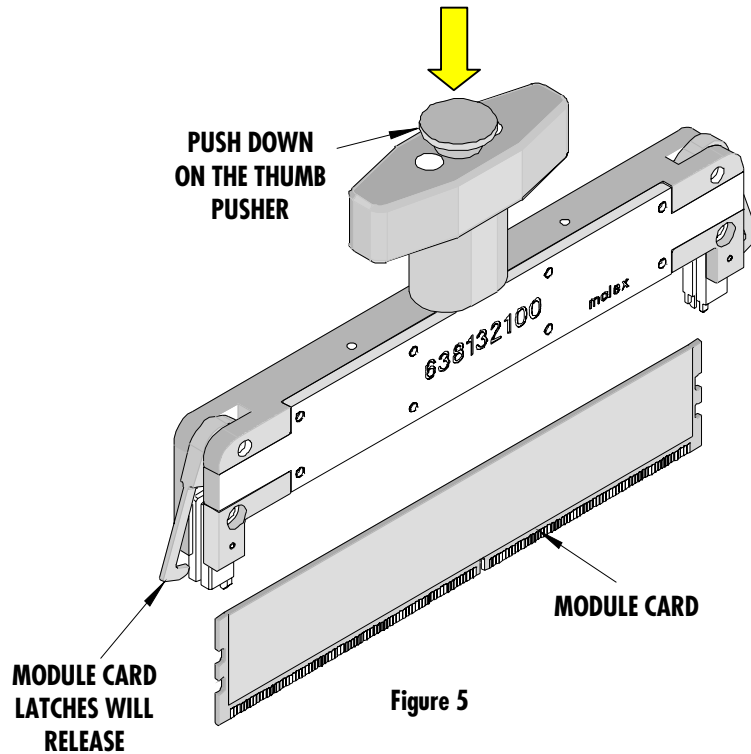

Figure 4

4. Pull the module card straight up with the handle of the extractor tool. See Figure 4.

5. When the module card is free of the housing, press down on the thumb pusher. This will open the module card latches and release the card from the extractor tool. See Figure 5.



## Maintenance

It is recommended that each operator of the tool be made aware of, and responsible for, the following maintenance steps:

1. Remove dust, moisture, and other contaminants with a clean brush, or soft, lint free cloth.
2. Do not use any abrasive materials that could damage the tool.
3. Make certain all pins; pivot points and bearing surfaces are protected with a thin coat of high quality machine oil. Do not oil excessively.
4. When tool is not in use, store in a clean, dry area.

**CAUTION:** Molex specifications are valid only when used with Molex terminals, applicators and tooling.

**PARTS LIST**

Item	Order No	Description	Quantity
	<b>63813-2100</b>	<b>Module Card Extractor Tool</b>	<b>(Figure 6)</b>
1	63813-2101	Extractor Base	1
2	63813-2102	Pusher Plate	1
3	63813-2103	Base Cover	1
4	63813-2204	Handle	1
5	63813-2205	Handle Shaft	1
6	63813-2206	Module Card Latch	2
7	63813-2207	Metal Latch Pusher	2
8	63600-2698	Knob	1
9	63600-2699	Metal Bushing	1
10	63600-2700	Compression Spring	1
11	63600-2701	Compression Spring	4
12	63600-2702	1.5mm Diameter Dowel Pin	2
13	63600-2703	M4 Screw Plug	4
14	63600-2704	M3 by 8 Long Low Head SHCS	2
15	N/A	M2.5 by 10 Long SHCS	**8
16	N/A	M3 by 35 Long SHCS	**2
17	N/A	4mm by 10 Long Dowel Pin	**2

\*\* Available from an industrial supply company such as MSC (1-800-645-7270).

**Assembly Drawing**

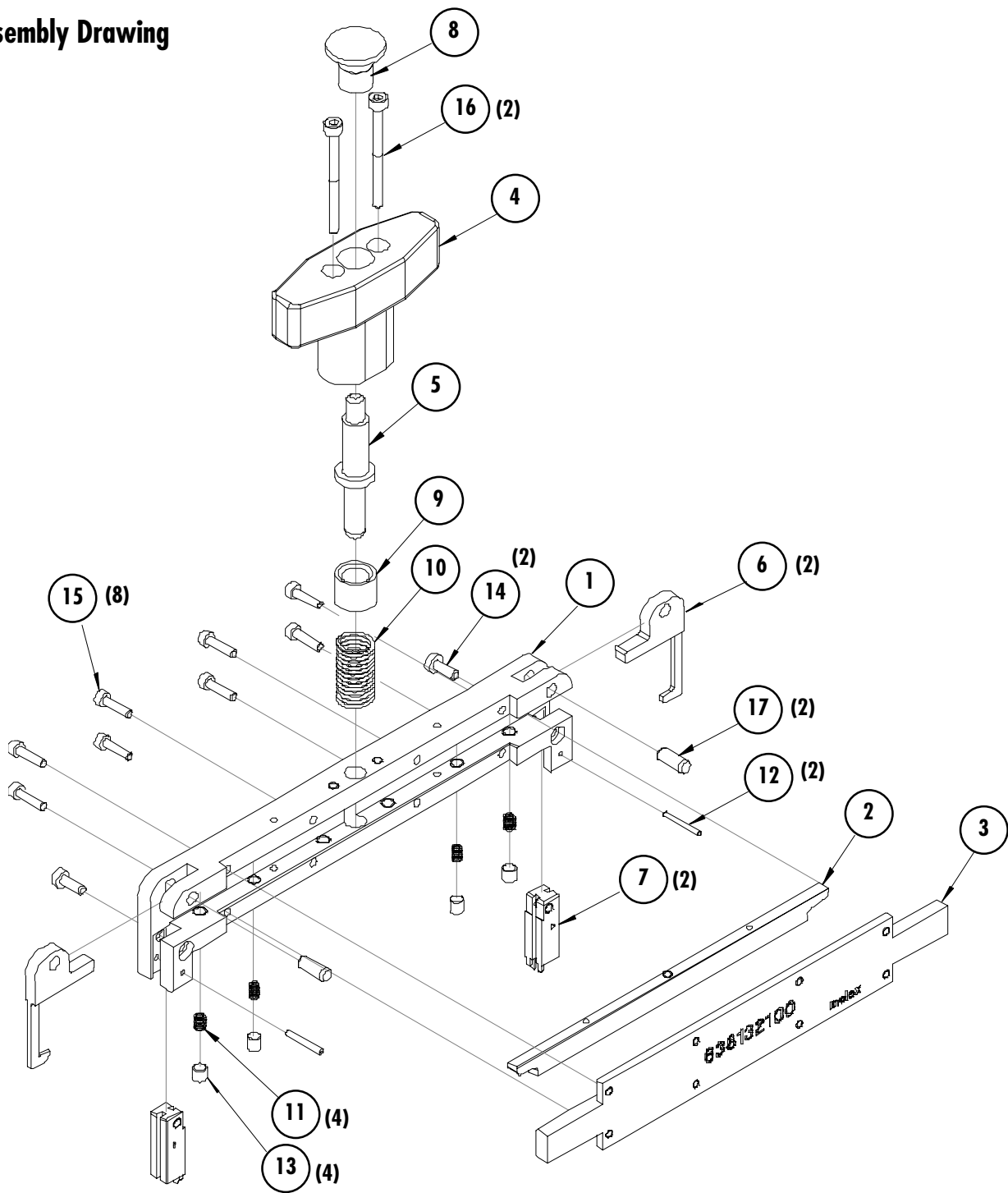

**Figure 6**

**Americas Headquarters**  
 Lisle, Illinois 60532 U.S.A.  
 1-800-78MOLEX  
 amerinfo@molex.com

**Far East North Headquarters**  
 Yamato, Kanagawa, Japan  
 81-462-65-2324  
 feninfo@molex.com

**Far East South Headquarters**  
 Jurong, Singapore  
 65-6-268-6868  
 fesinfo@molex.com

**European Headquarters**  
 Munich, Germany  
 49-89-413092-0  
 eurinfo@molex.com

**Corporate Headquarters**  
 2222 Wellington Ct.  
 Lisle, IL 60532 U.S.A.  
 630-969-4550  
 Fax: 630-969-1352

Visit our Web site at <http://www.molex.com>