



Chipsmall Limited consists of a professional team with an average of over 10 year of expertise in the distribution of electronic components. Based in Hongkong, we have already established firm and mutual-benefit business relationships with customers from,Europe,America and south Asia,supplying obsolete and hard-to-find components to meet their specific needs.

With the principle of “Quality Parts,Customers Priority,Honest Operation,and Considerate Service”,our business mainly focus on the distribution of electronic components. Line cards we deal with include Microchip,ALPS,ROHM,Xilinx,Pulse,ON,Everlight and Freescale. Main products comprise IC,Modules,Potentiometer,IC Socket,Relay,Connector.Our parts cover such applications as commercial,industrial, and automotives areas.

We are looking forward to setting up business relationship with you and hope to provide you with the best service and solution. Let us make a better world for our industry!



## Contact us

Tel: +86-755-8981 8866 Fax: +86-755-8427 6832

Email & Skype: info@chipsmall.com Web: www.chipsmall.com

Address: A1208, Overseas Decoration Building, #122 Zhenhua RD., Futian, Shenzhen, China





Extractor Tool

## Application Tooling Specification Sheet

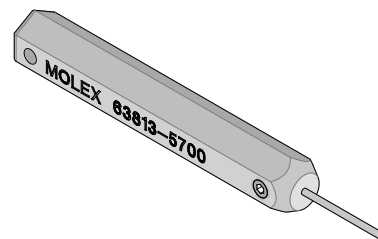

Order No. 63813-5700

### FEATURES

- The 63813-5700 Extraction Tool is used on several different connector series. See below.

### SCOPE

Products:

Terminal Series No.	Description	Housing Series and Order No.				Terminal Order No.	
502306	CTX64, 0.64 mm (.030") Female Crimp Terminals	34728	34729			502306-0211	502306-0212
						502306-0213	502306-0214
87396	2.00mm (.079") Pitch, Milli-Grid™ Crimp Terminals	51110				87396-8051	87396-8100
						87396-8999	
Seal	◆ FCI Incorporated "SICMA" Type Seal Caps for NSCC Seal Connector 8 and 10 circuits.	98788-1081	98788-1088	98788-1101	98788-1108		
		98788-1201	98788-1208	98789-1081	98789-1088		
		98789-1101	98789-1108	98789-1201	98789-1208		
200449	EdgeLock	200448	200448-0001			200449-0001	

◆NOTE: The Seal Cap is not supplied from Molex.

### DESCRIPTION:

Extraction Tool is used on extract terminals from several different connector series.

It is 57.3 mm (2.26 in.) long by 6.35mm (.25 in.) diameter, and weight about 0.03kg (1 oz.). See Figure 1.

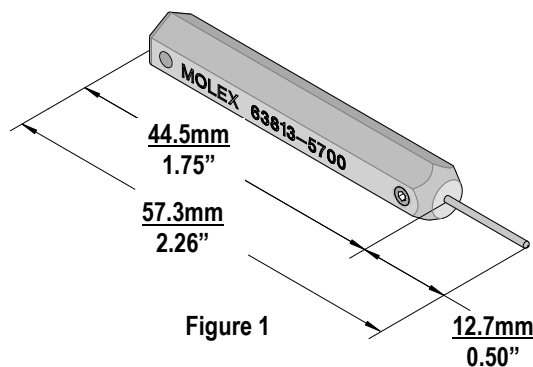

### OPERATION:

#### For 502306 Terminal Series:

When removing a damaged crimped wire from the CTX64 connector follow the steps below:

- The TPA lock on the CTX64 connector will need to be opened first.
- Using a small screwdriver insert the flat edge under the tab of the TPA lock. See Figure 1.

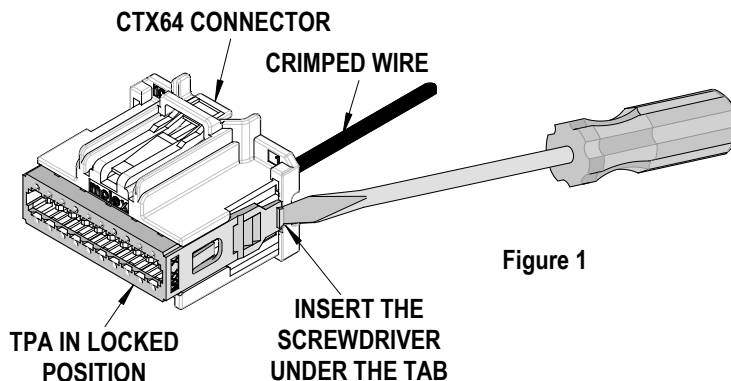

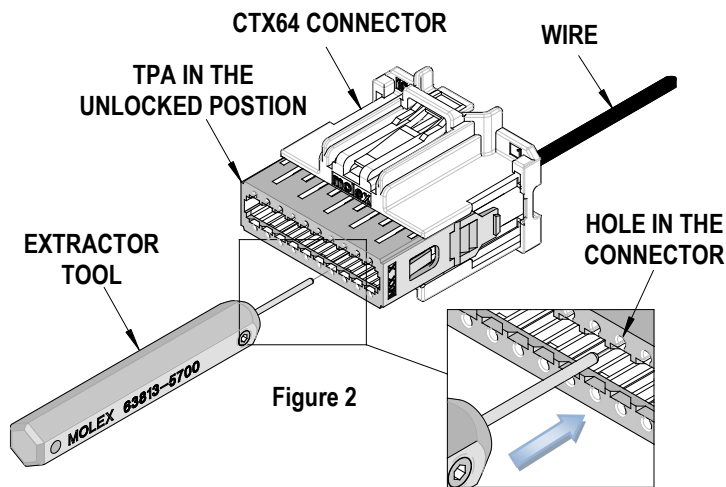

Figure 2

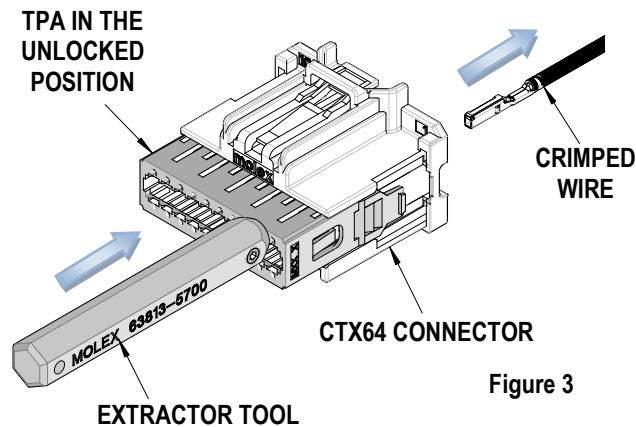

Figure 3

3. Pull up and push out towards the front of the housing until it stops.
4. Repeat this on the opposite side of the TPA lock.
5. Position the blade of the extraction tool into the small hole (in line with the terminal to be removed) in the front face of the housing as shown in Figure 2.
6. Push extractor tool into the small hole until it clicks or comes to a stop. Do not force the extractor tool any farther, otherwise it may damage the housing.
7. Holding the extractor tool against the housing, gently pull the crimped wire out of the connector. See Figure 3.

**For 87396 Terminal Series:**

When removing a damaged crimped wire from the Milli-Grid™ connector follow the steps below:

**Note: The housing has locking tabs on both sides, so determine what side the terminal locking tab is located.**

1. Push the terminal forward into the housing before using the Extractor Tool.
2. Insert the round tip of the extractor tool under the appropriate housing tab. See Figure 4.
3. Gently lift up on the housing tab, and push the terminal back through the connector slot. While pulling the terminated wire out in the direction of the arrow. See Figure 4.

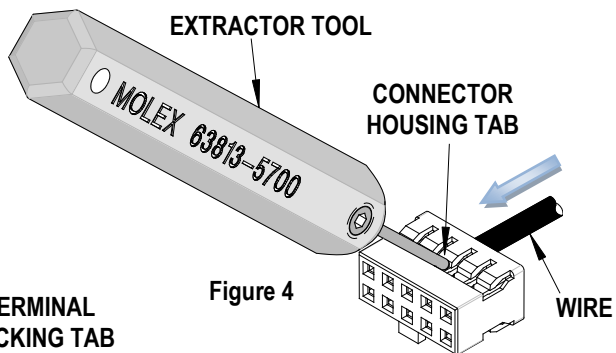

Figure 4

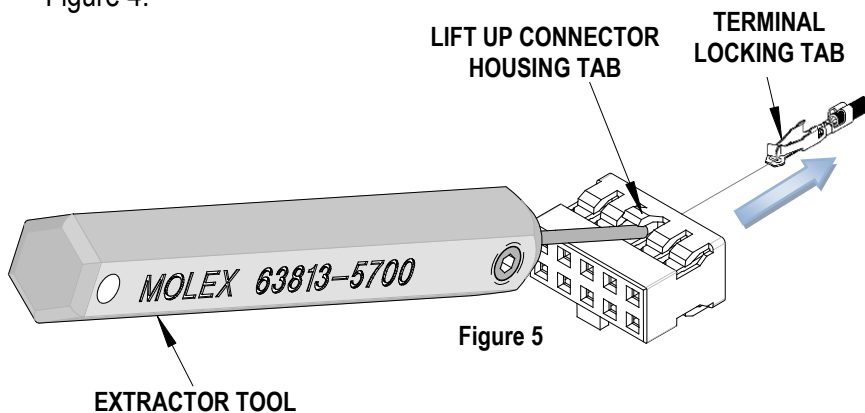

Figure 5

**For removing the seal plug from the 98788 and 98789 Housing Series:**

When removing a damaged FCI seal from the NSCC receptacle housing follow the steps below:

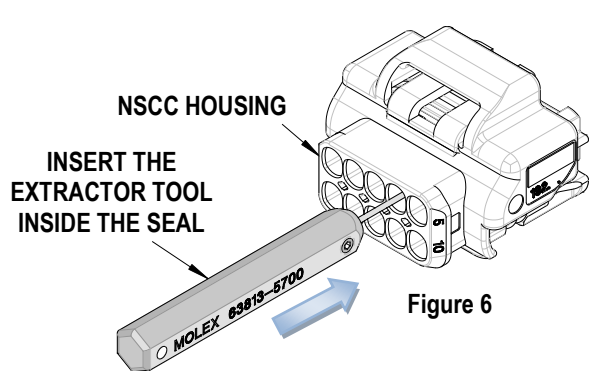

Figure 6

1. Insert the extractor tool into the seal plug hole. See Figure 6.
2. Tilt the extractor tool up at an angle. See Figure 7.
3. Gently pull out the extractor tool with the seal plug attached.

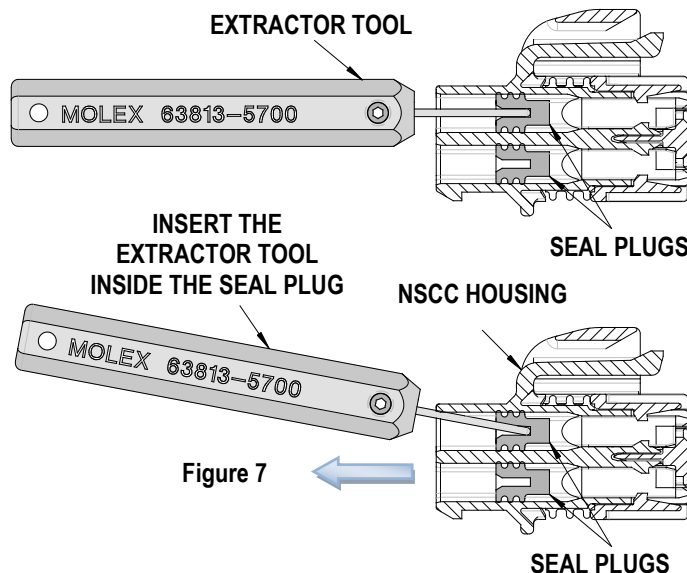

Figure 7

**⚠ WARNING:** There should be no contact between the extractor tool and the terminal cavity sealing area.

All housings or seals that are damaged must be replaced.

**For 200449 Terminal Series:**

When removing a damaged crimped wire from the EdgeLock™ connector follow the steps below:

1. Push the terminal forward into the housing before using the Extractor Tool.
2. Position the blade of the extraction tool into the small slot (in line with the terminal to be removed) in the front face of the housing as shown in Figure 8.
3. Push extractor tool into the small hole until it comes to a stop. Do not force the extractor tool any farther, otherwise it may damage the housing.
4. The extractor pin will depress the terminal locking tab, then pull the terminated wire out of the housing as shown. Wiggling the wire while pulling it out will help. See Figure 9.

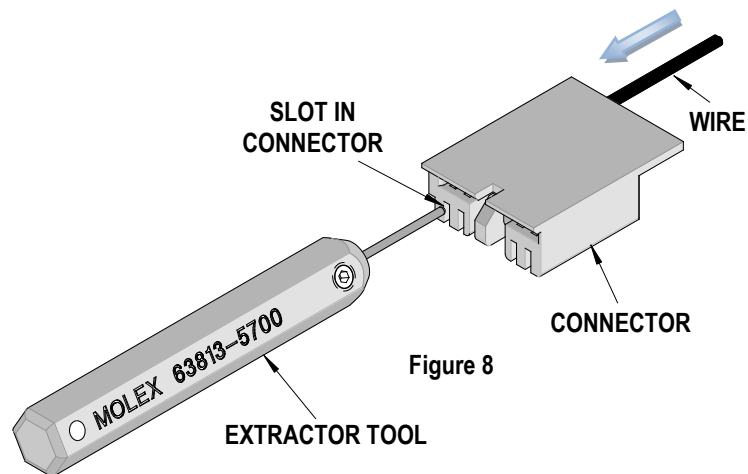

Figure 8

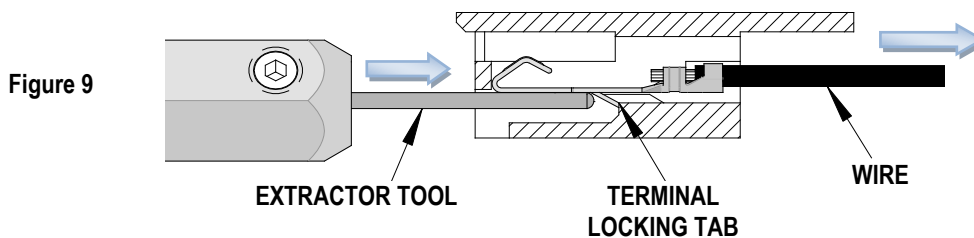

Figure 9

**CAUTION:** This extractor tool should be used to extract the terminal or seal cap only. Using it for unintended purposes may cause injury or damage to parts. Be careful not to deform the end of the terminal. Avoid lifting the housing lock too high.

**CAUTION:** Molex specifications are valid only when used with Molex terminals, applicators and tooling.

Molex does not offer repair parts for Extractor Tools due to the inexpensive nature of these tools.

### **Contact Information**

For more information on Molex application tooling please contact your nearest Molex location shown below.

Visit our Web site at <http://www.molex.com>