



Chipsmall Limited consists of a professional team with an average of over 10 year of expertise in the distribution of electronic components. Based in Hongkong, we have already established firm and mutual-benefit business relationships with customers from,Europe,America and south Asia,supplying obsolete and hard-to-find components to meet their specific needs.

With the principle of “Quality Parts,Customers Priority,Honest Operation,and Considerate Service”,our business mainly focus on the distribution of electronic components. Line cards we deal with include Microchip,ALPS,ROHM,Xilinx,Pulse,ON,Everlight and Freescale. Main products comprise IC,Modules,Potentiometer,IC Socket,Relay,Connector.Our parts cover such applications as commercial,industrial, and automotives areas.

We are looking forward to setting up business relationship with you and hope to provide you with the best service and solution. Let us make a better world for our industry!



Contact us

Tel: +86-755-8981 8866 Fax: +86-755-8427 6832

Email & Skype: info@chipsmall.com Web: www.chipsmall.com

Address: A1208, Overseas Decoration Building, #122 Zhenhua RD., Futian, Shenzhen, China





Extractor Tool Instruction Sheet Order No. 63813-6300

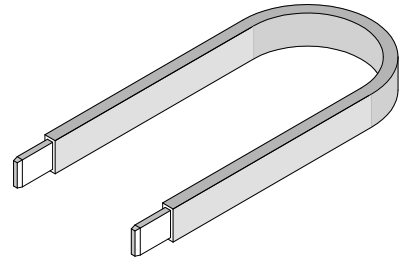

FEATURES

- This Tool removes the HDX™ the Wire Cap Assembly from the Standard Module Frame from the 30-Way HDX™ Module.
- Use Extractor Tool 63813-6200 to remove the HDX™ Female Module, Series 98627 from the 15-30-Way HDX™ Female Module.
- Use Extractor Tool 63813-6200 to remove the HDX™ female crimp terminals, Series 98587 from the 15-30-Way HDX™ Female Module.

SCOPE

Products: HDX™ Standard Module Frame with Lever 15 and 30-Way.
 HDX™ Female Module, 15 and 30-Way.
 HDX™ Female Crimp Terminal, 0.635mm (.025"), AWG 20-24 (0.22-0.60mm²).

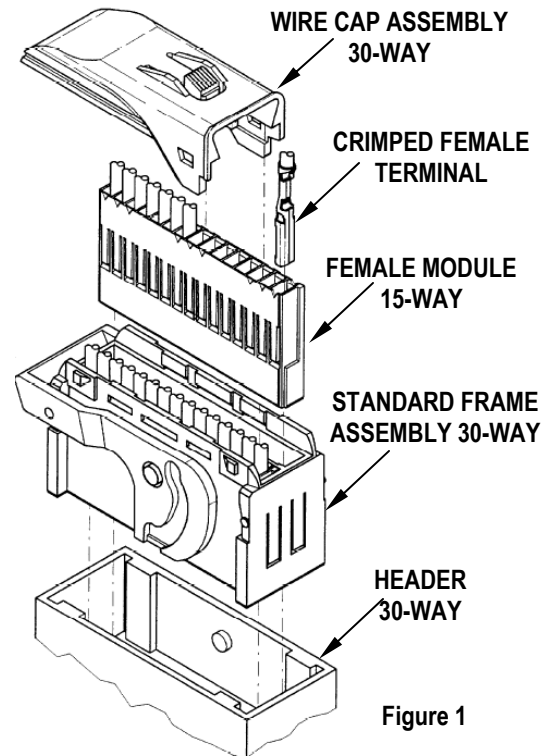

Figure 1

Way (Circuits)	Standard Frame Order No.				Wire Cap Assembly	Module Order No	Terminal Order No.
15	98625-2001	98625-2002	98625-2003	98625-2004	98633-1001	98627-1001 98627-1002	98587-0013 98587-0014
30	98631-1001	98631-1002	98631-1003	98631-1004			
	98631-2001	98631-2002	98631-2003	98631-2004			
	98631-2011	98631-2012	98631-2013	98631-2014			

OPERATION:

To remove the HDX™ Wire Cap Assembly 30-Way from the Standard Frame Module, follow the steps below:

1. Place the extractor tool into the two slots on the front of the wire cap assembly and between the Frame Module.
2. Gently push in the extractor tool until the latches of the Frame Module depress. See Figure 2.

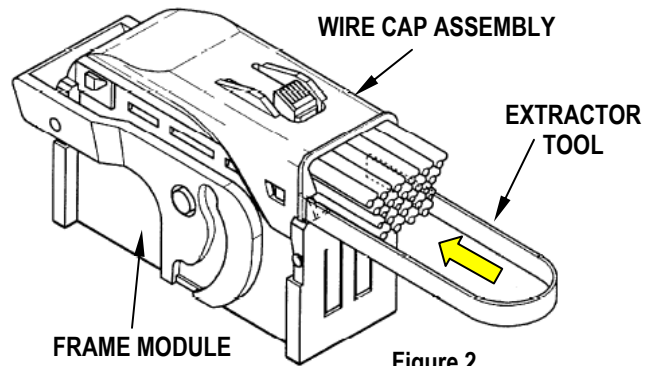
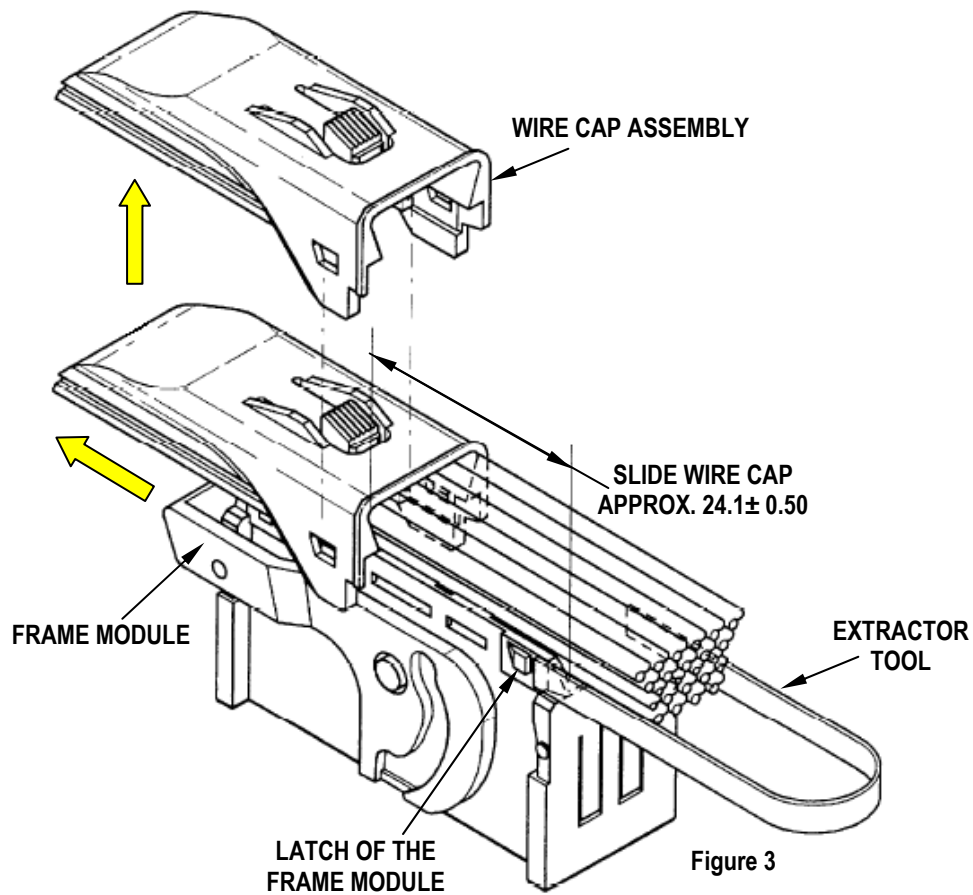

Figure 2

3. Slide the Wire Cap Assembly back approximately $24.1 \pm 0.50\text{mm}$ over the wires.



4. Lift up the Wire Cap Assembly making sure the cap is free of the wires. See Figure 3.

CAUTION: Molex specifications are valid only when used with Molex terminals, modules, and tooling.

Contact Information

For more information on Molex application tooling please contact Molex at 1-800-786-6539.

Americas Headquarters
Lisle, Illinois 60532 U.S.A.
1-800-78MOLEX
amerinfo@molex.com

Far East North Headquarters
Yamato, Kanagawa, Japan
81-462-65-2324
feninfo@molex.com

Far East South Headquarters
Jurong, Singapore
65-6-268-6868
fesinfo@molex.com

European Headquarters
Munich, Germany
49-89-413092-0
eurinfo@molex.com

Corporate Headquarters
2222 Wellington Ct.
Lisle, IL 60532 U.S.A.
630-969-4550
Fax: 630-969-1352

Visit our Web site at <http://www.molex.com>