



Chipsmall Limited consists of a professional team with an average of over 10 year of expertise in the distribution of electronic components. Based in Hongkong, we have already established firm and mutual-benefit business relationships with customers from,Europe,America and south Asia,supplying obsolete and hard-to-find components to meet their specific needs.

With the principle of “Quality Parts,Customers Priority,Honest Operation,and Considerate Service”,our business mainly focus on the distribution of electronic components. Line cards we deal with include Microchip,ALPS,ROHM,Xilinx,Pulse,ON,Everlight and Freescale. Main products comprise IC,Modules,Potentiometer,IC Socket,Relay,Connector.Our parts cover such applications as commercial,industrial, and automotives areas.

We are looking forward to setting up business relationship with you and hope to provide you with the best service and solution. Let us make a better world for our industry!



## Contact us

Tel: +86-755-8981 8866 Fax: +86-755-8427 6832

Email & Skype: info@chipsmall.com Web: www.chipsmall.com

Address: A1208, Overseas Decoration Building, #122 Zhenhua RD., Futian, Shenzhen, China



		 <p><b>TYPE 4C</b></p>
<p><b>Tool Kit</b> <b>Order No. 63823-6470</b></p>	<p><b>Application Tooling</b> <b>Specification Sheet</b></p>	<p><b>Hand Crimp Tool</b> <b>Order No. 63823-6400</b></p>

**FEATURES**

- % A full cycle ratcheting hand tool ensures complete crimps
- % Ergonomically designed soft handles
- % Precisely designed crimping profiles with simple contact positioning
- % Easy handling due to outstanding force ratio
- Tool kits are easily installed into the Hand Crimp Tool or the 63816-0300 Power Crimp Head which is installed into the 63816-0200 (110 V) or the 63816-0250 (220 V) Battery Powered Tool.
- Many different Tool kits can be used with a single Battery Powered Tool.
- This tool is IPC/WHMA-A-620 Class 2 and RoHS compliant.

**SCOPE**

Products: PV Solar Pin and Socket Crimp Terminals, 10-14 AWG (6.0-2.5mm<sup>2</sup>)

Terminal Series No.	Terminal Order No.		Wire Size and Type		Insulation Diameter (ref)		Strip Length	
	Loose	*Reel only	AWG	mm <sup>2</sup>	mm	In.	mm	In.
130196	130196-0310	130196-0314	10-12	6.00-4.00	7.8	.31	7.00-10.00	.276-.394
	130196-0313	130196-0315	14	2.50	6.7	.26	7.00-10.00	.276-.394
130197	130197-0325	130197-0346	10-12	6.00-4.00	7.8	.31	7.00-10.00	.276-.394
	130197-0336	130197-0347	14	2.50	6.7	.26	7.00-10.00	.276-.394
93302	93302-0006	93302-0004	10-12	6.00-4.00	7.8	.31	7.00-10.00	.276-.394
	93302-0005	93302-0003	14	2.50	6.7	.26	7.00-10.00	.276-.394
93303	93303-0005	93303-0003	10-12	6.00-4.00	7.8	.31	7.00-10.00	.276-.394
	93303-0006	93303-0004	14	2.50	6.7	.26	7.00-10.00	.276-.394

\*Customer to cut off terminal from reel: 0.50mm (.020") maximum Cut-off Tab.

**DEFINITION OF TERMS**

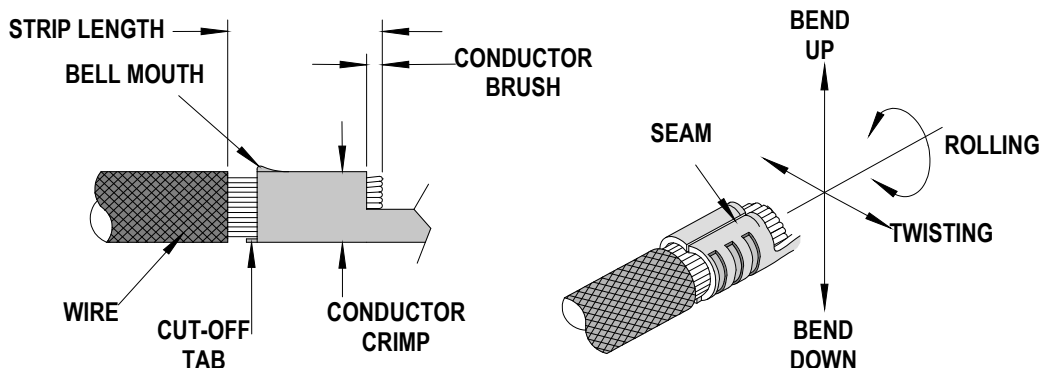

The above terminal drawing is a generic terminal representation. It is not an image of a terminal listed in the scope.

**CONDITIONS:**

Terminal Series No.	Wire Size		Bell mouth		Cut-off Tab Maximum		Conductor Brush	
	AWG	mm <sup>2</sup>	mm	In.	mm	In.	mm	In.
130196 and 93302	10-14	6.00-2.50	0.20-1.50	.008-.059	0.50	.020	1.00-3.00	.039-.118
130197 and 93303	10-14	6.00-2.50	0.20-1.50	.008-.059	0.50	.020	1.00-3.00	.039-.118

Terminal Series No.	Wire Size		Bend up Bend down		Twist	Roll	Punch Width (Ref)		Seam	
	AWG	mm <sup>2</sup>	Degree				Conductor			
				Degree		mm	In			
130196 and 93302	10-12	6.00-4.00	3	3	4	8	3.90	.154		Seam shall not be open and no wire allowed out of the crimping area
	14	2.50	3	3	4	8	2.90	.114		
130197 and 93303	10-12	6.00-4.00	3	3	4	8	3.90	.154		
	14	2.50	3	3	4	8	2.90	.114		

After crimping, the conductor profile should measure the following.

Terminal Series No.	Wire Size		Conductor Crimp Height		Pull Force Minimum	
	AWG	mm <sup>2</sup>	mm	In.	N	Lb.
130196 and 93302	10	6.00	2.10-2.20	.083-.087	356.0	80.0
	12	4.00	2.00-2.10	.079-.083	312.0	70.0
	14	2.50	1.60-1.70	.063-.067	223.0	50.0
130197 and 93303	10	6.00	2.10-2.20	.083-.087	356.0	80.0
	12	4.00	2.00-2.10	.079-.083	312.0	70.0
	14	2.50	1.60-1.70	.063-.067	223.0	50.0

The above specifications are guidelines to an optimum crimp.

**Note:**

A crimp height chart is provided with this manual as Reference Only. Due to the wide range of wires and stranding, actual crimp height measurements may vary slightly. An occasional, destructive, pull force test should be preformed to check hand tool crimp. Pull force value must exceed the minimum pull force specifications listed.

**CAUTION:** Install only Molex terminals listed above with this tool. Do not crimp hardened objects as damage can occur to the tool or die.

**INSTALLATION**

To install the Tool Kit into the Power Crimp Head follow the steps below:

**Anvil and Punch Installation**

1. Insert the Anvil into the bottom slots of the nest. Install the M4 x 10 long BHCS and tighten in place.
2. Insert the Punch into the top slots of the nest. Install the M4 x 18 long BHCS and tighten in place. See Figure 1.

**Locator Installation and Removal**

Follow the steps below to install or replace the locator. See Figure 2.

**To install the locator**

1. Position the locator with the hole over the brass pivot shaft and snap it into place.

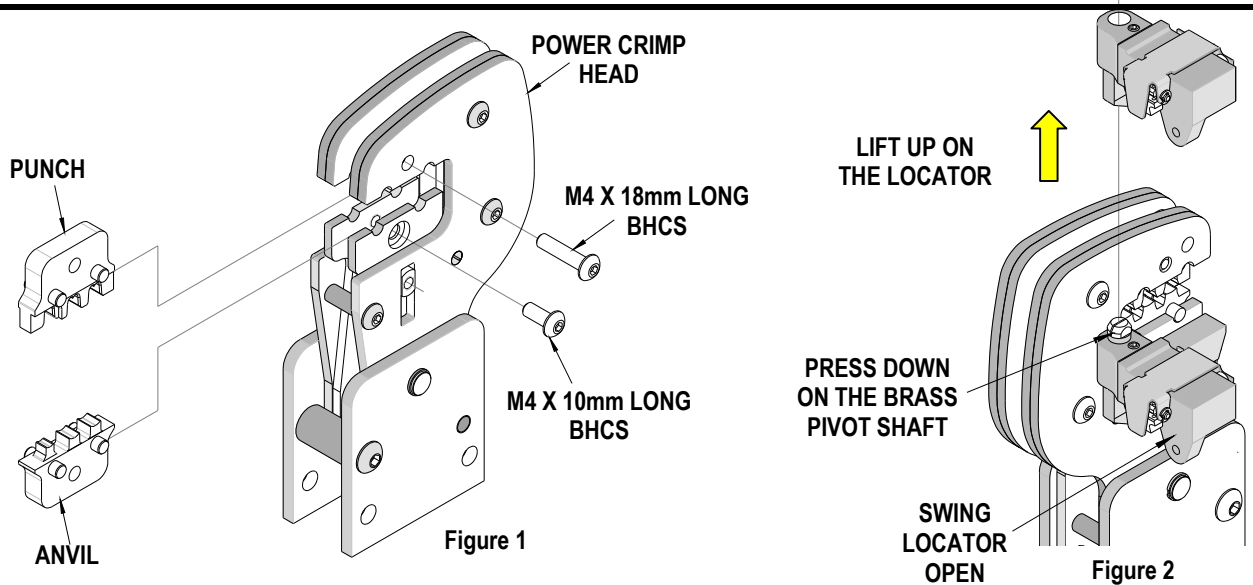

**To remove the locator**

1. Open the crimp hand tool.
2. Swing the existing locator open and away from the hand tool.
3. Firmly press down on the brass pivot shaft with your thumb, while pulling the locator up. Slip the locator off the top of the brass pivot shaft.

**OPERATION**

Open the tool by squeezing the handles together, at the end of the closing stroke, the ratchet mechanism will release the handles, and the hand tool will spring open.

**Crimping Terminals**

1. Select the desired terminal listed in the preceding charts.
2. Turn the Locator Lock Latch down to unlock. See Figure 3.

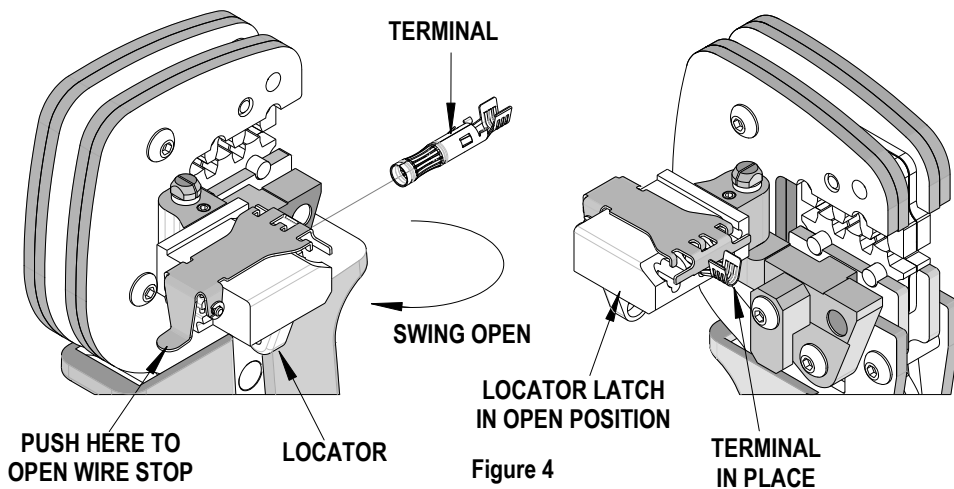
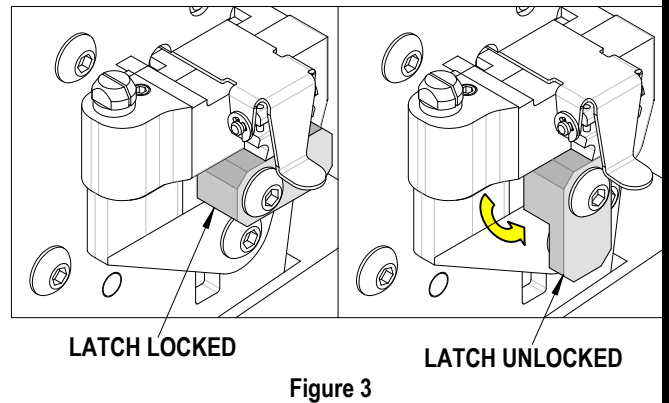

Hand Tool for PV Solar Pin and Socket Crimp Terminals

3. Swing the terminal locator away from the crimp tool shown in Figure 4. Some terminals with large conductor grips may interfere with the crimp tooling when swinging the locator into position. The terminal must then be loaded into the locator in the closed/crimp position. See Figure 5.
4. Press down on the wire stop on the locator as shown in Figure 1. Insert the proper terminal into the proper nest opening. Make sure when choosing the nest opening, it will correspond with the 10, 12 or 14 profile on the hand tool.
5. Return the locator to its original position.

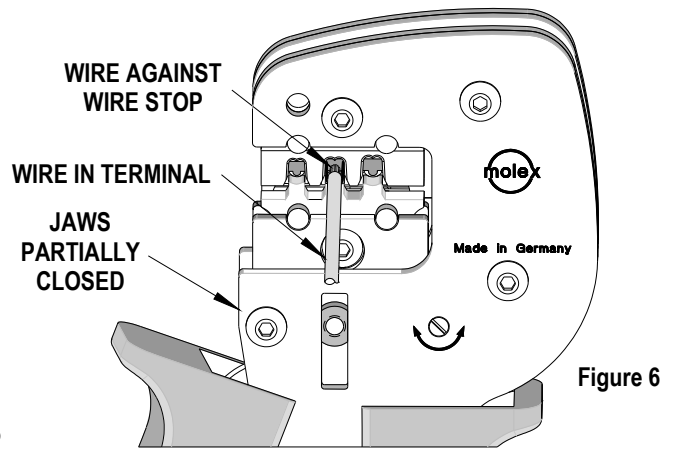
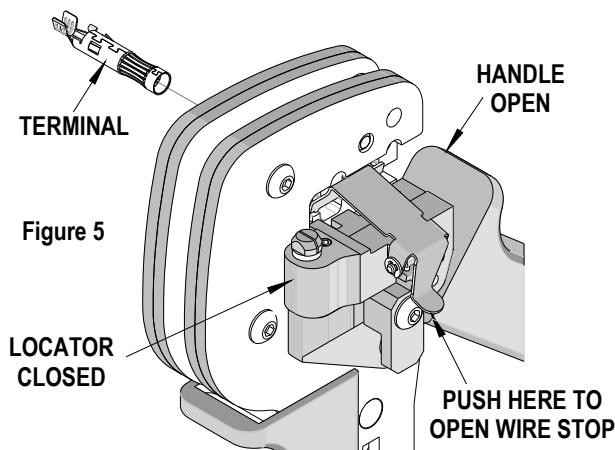

6. Turn the Locator Lock Latch up to lock. Make sure that the terminal is visually centered over the punch.
7. Insert the proper wire over the terminal.
8. Gently touch the wire stop with the end of the wire. See Figure 6 and 7.
9. Crimp the terminal by squeezing the tool handles until the ratchet mechanism cycle has been completed. Release handles to open the jaws.
10. Remove the crimped terminal from the terminal locator by pressing down on the wire stop and gently pulling on the wire.
11. Visually inspect the crimped terminal for proper crimp location.

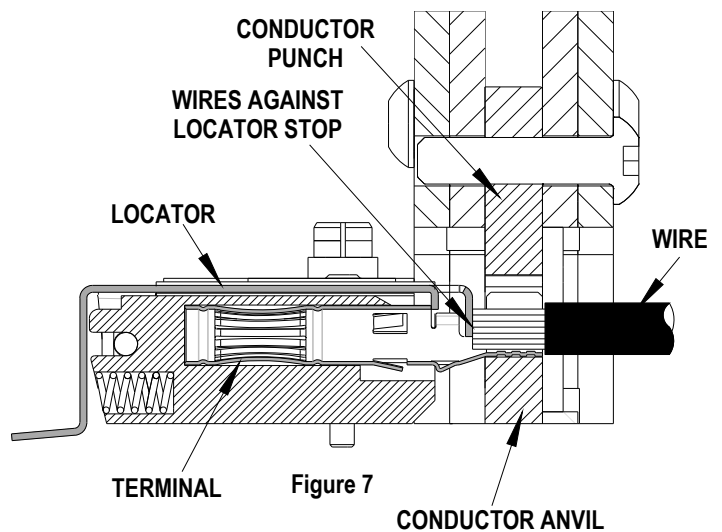

**Note:** The tamper proof ratchet action will not release the tool until it has been fully closed.

**For the Battery Power Tool:**

1. Cycle the Battery Power Tool to crimp the terminal to the wire.
2. Remove the crimped terminal from the terminal locator by pressing down on the wire stop and gently pulling on the wire.
3. Visually inspect the crimped terminal for proper crimp location.

## Maintenance

It is recommended that each operator of the tool be made aware of, and responsible for, the following maintenance steps:

1. Remove dust, moisture and other contaminants with a clean brush, or soft, lint-free cloth.
2. Do not use any abrasive materials that could damage the tool.
3. Make certain all pins; pivot points and bearing surfaces in the tool head are protected with a thin coat of high quality machine oil. Do not oil excessively. This tool was engineered for durability, but like any fine piece of equipment, it needs cleaning and lubrication for a maximum service life of trouble-free crimping. The use of light oil, such as 30 weight automotive oil, every 5,000 crimps or monthly, will significantly enhance the tool life and ensure a stable calibration. See Figure 8A or 8B for lubrication points.
4. Store the tool in a clean and dry area when not in use.

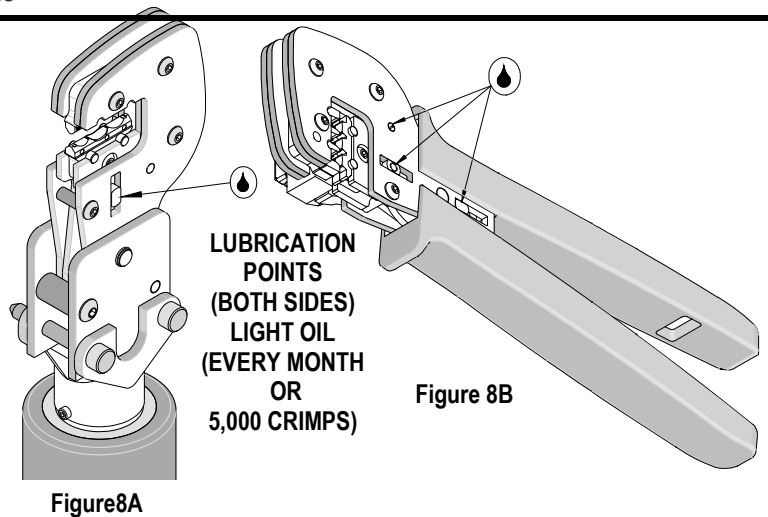

## Miscrimps or Jams for Crimp Hand Tools Only (See Figure 11)

Should this tool ever become stuck or jammed in a partially closed position, **Do Not force the handles open or closed.** The tool will open easily by rotating the small slotted screw marked with an arrow. See Figure 11.

## Warranty

This tool kit is for electrical terminal crimping purposes only. This tool kit is made of the best quality materials. All vital components are long life tested. All tools are warranted to be free of manufacturing defects for a period of 30 days. Should such a defect occur, we will repair or exchange the tool kit free of charge. This repair or exchange will not be applicable to altered, misused, or damaged tools.

**CAUTION:** Molex crimp specifications are valid only when used with Molex terminals and tooling.

## CAUTIONS

1. Manually powered hand tools are intended for low volume or field repair. This tool is **NOT** intended for production use. Repetitive use of this tool should be avoided.
2. Insulated rubber handles are not protection against electrical shock.
3. Wear eye protection at all times.
4. Use only the Molex terminals specified for crimping with this tool.

**CAUTION:** Repetitive use of this tool should be avoided.

**Certification**

Molex does not certify or re-certify commercial grade hand tools but rather supplies the following guidelines for customers to re-certify hand tools.

- % This tool is qualified to pull force only. To re-certify, crimp a terminal to a wire, which has been stripped 12.7mm (1/2") long, so there is no crimping of the insulation. Pull the terminal and wire at a rate no faster than 25mm (1.00") per minute. See the Molex web site for the Quality Crimp Handbook for more information on pull testing.
- % When the hand tool is no longer capable of achieving minimum pull force, it should be taken out of service and replaced.
- % This tool is very difficult to disassemble and reassemble. Customer repair is not recommended.

The chart below shows all applications for this Tool Kit.

Tool Kit Order No.	Tool Order no.	Tool Description	Power Head Order No.	Adapter Description	Figure No.
63823-6470	63810-1000	Hand Crimp Frame (Long)	N/A	N/A	9
	63816-0200	Battery Power Tool (110 V)	63816-0300	Power Crimp Head	10
	63816-0250	Battery Power Tool (220 V)	63816-0300	Power Crimp Head	10

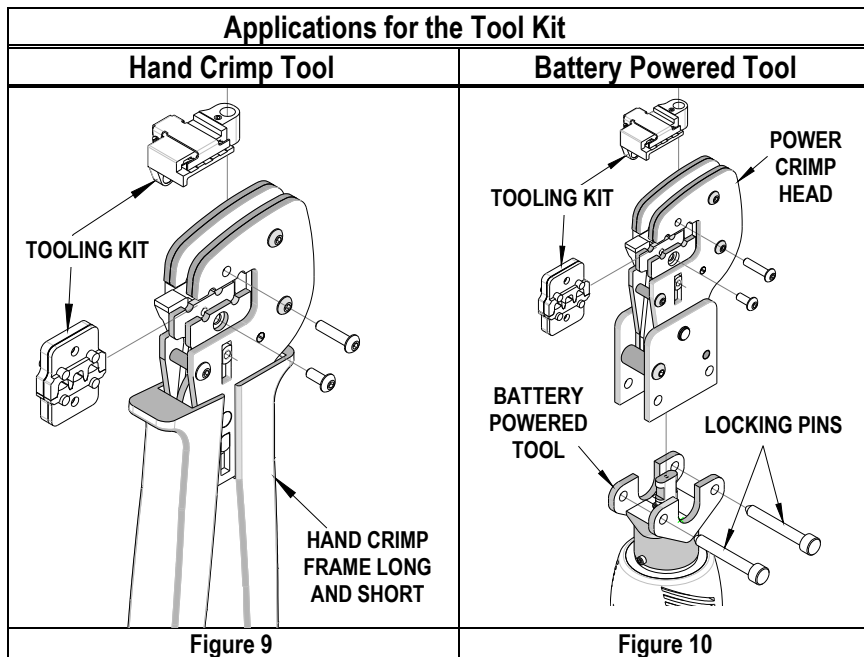

**WARNING:** NEVER operate service, install tool kits, or adjust the Power Crimp Head without proper instruction and without first reading and understanding the instructions in the proper Manual or Specification Sheet. See Chart above for the correct Manual or Specification Sheet.

**WARNING:** NEVER install tooling or service this tool while it is connected to any power source. Make sure the power is disconnected.

**CAUTION:** To prevent injury, keep fingers away from the crimping area when operating this tool.

**CAUTION:** Wear safety glasses when operating or servicing this tool.

### HAND TOOL PARTS LIST

Item Number	Order Number	Description	Quantity
1	63810-1000	Hand Crimp Frame (Long)	1
2	63823-6470	Tool Kit with Locator	1
3	63823-6475	Locator (only)	REF

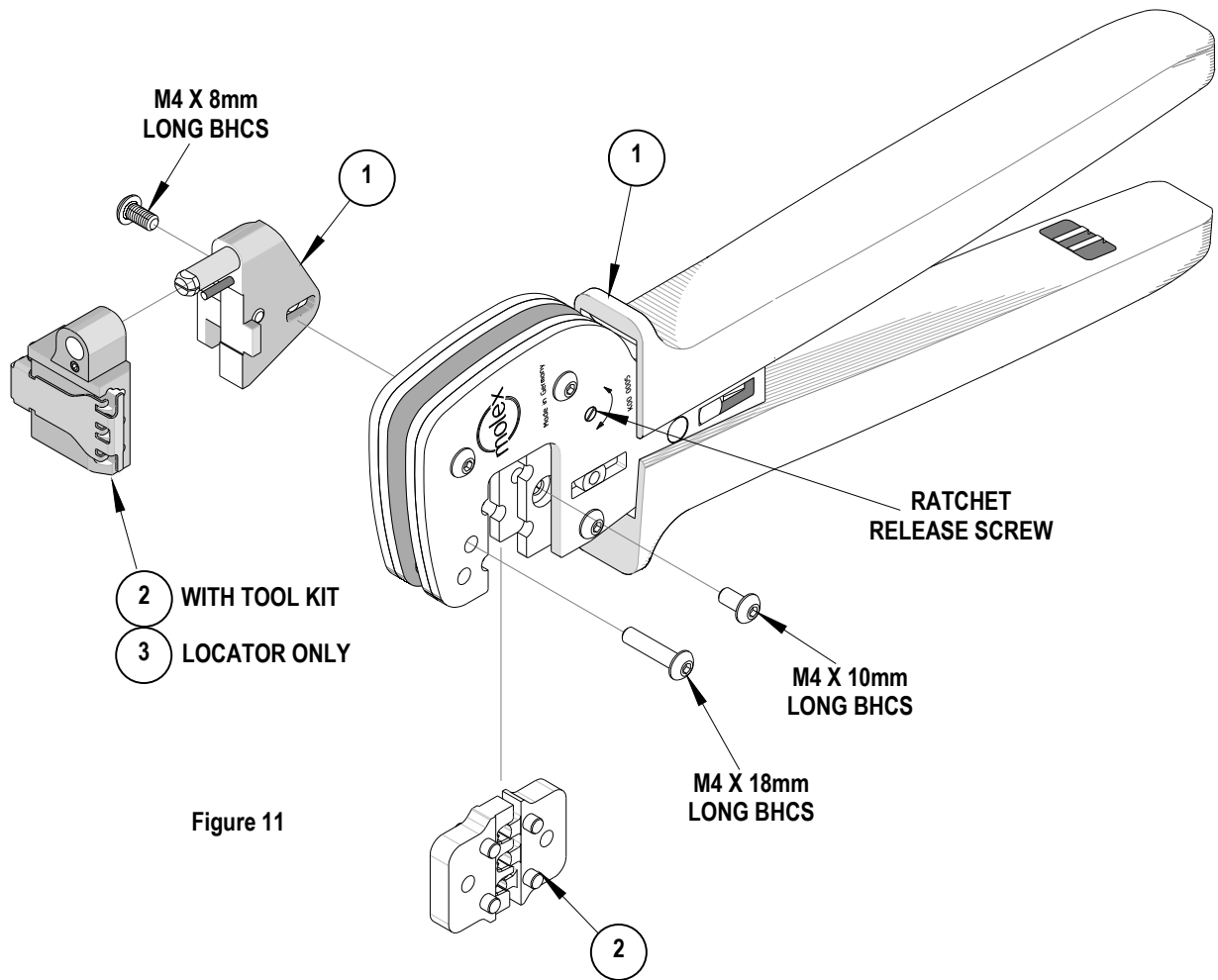
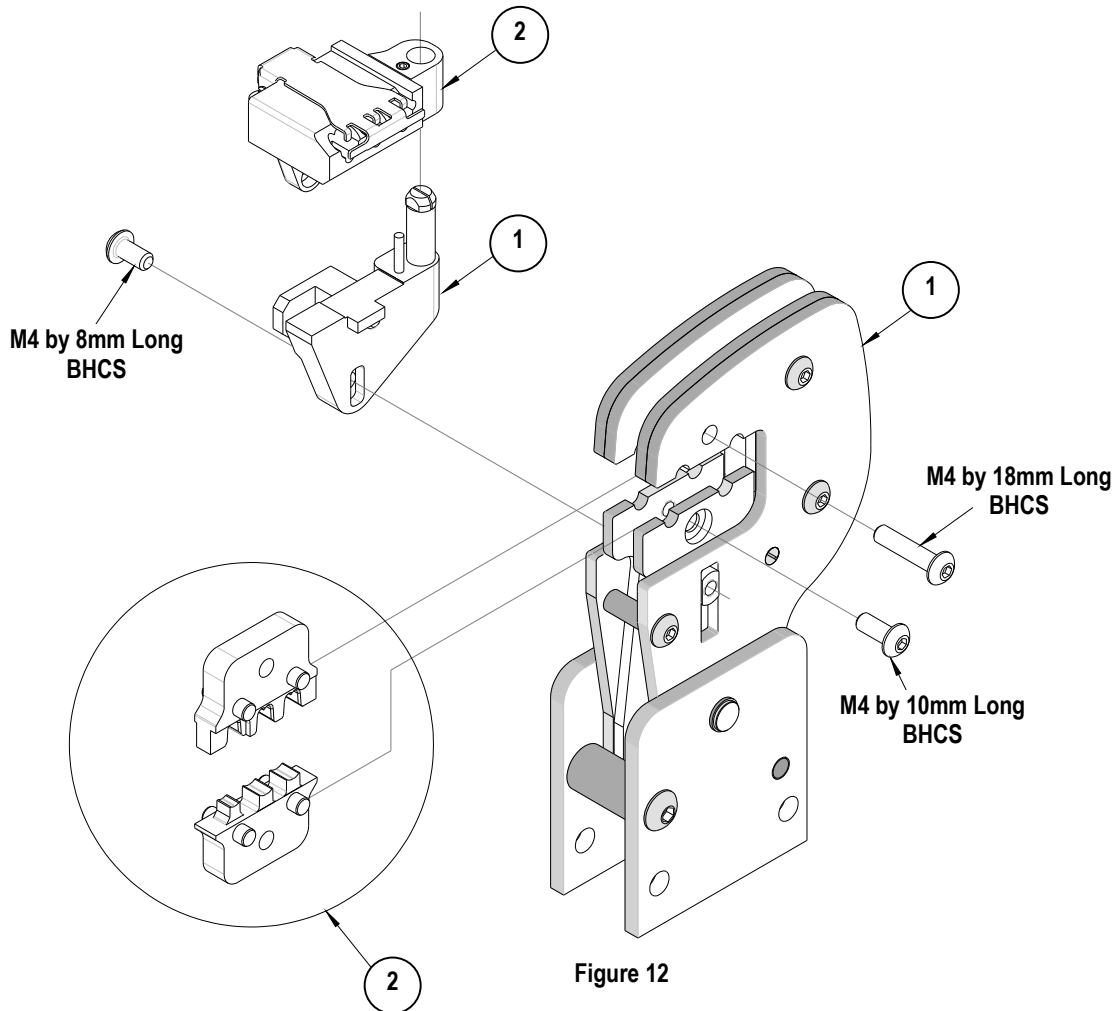

Figure 11



**POWER HEAD PARTS LIST**

Item	Order No	Engineering No.	Description	Quantity
1	63816-0300	63816-0300	Power Crimp Head	1
2	63823-6470	63823-6470	Tool Kit	1



<http://www.molex.com>