



Chipsmall Limited consists of a professional team with an average of over 10 year of expertise in the distribution of electronic components. Based in Hongkong, we have already established firm and mutual-benefit business relationships with customers from,Europe,America and south Asia,supplying obsolete and hard-to-find components to meet their specific needs.

With the principle of “Quality Parts,Customers Priority,Honest Operation,and Considerate Service”,our business mainly focus on the distribution of electronic components. Line cards we deal with include Microchip,ALPS,ROHM,Xilinx,Pulse,ON,Everlight and Freescale. Main products comprise IC,Modules,Potentiometer,IC Socket,Relay,Connector.Our parts cover such applications as commercial,industrial, and automotives areas.

We are looking forward to setting up business relationship with you and hope to provide you with the best service and solution. Let us make a better world for our industry!



## Contact us

Tel: +86-755-8981 8866 Fax: +86-755-8427 6832

Email & Skype: info@chipsmall.com Web: www.chipsmall.com

Address: A1208, Overseas Decoration Building, #122 Zhenhua RD., Futian, Shenzhen, China





Extractor Tool

## Application Tooling Specification Sheet

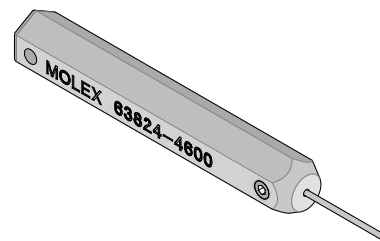

Order No. 63824-4600

### FEATURES

- The 63824-4600 Extraction Tool is designed to remove crimp terminals from Nano-Fit™ power connectors. See below.

### SCOPE

Products: Nano-Fit™ Power Connectors and Crimp Terminals 20-26 AWG.

Terminal Series No.	Terminal Order No.	Housing Series No.	Housing Order No.				
			105307-1102	105307-1103	105307-1104	105307-1105	105307-1106
105300 20-26 AWG Nano-Fit™	105300-1100 105300-1200 105300-1300 105300-2100 105300-2200 105300-2300	105307	105307-1107	105307-1108	105307-2101	105307-2103	105307-2104
			105307-2105	105307-2106	105307-2107	105307-2108	
			<b>With TPA Feature</b>				
		105308	105308-1102	105308-1103	105308-1104	105308-1105	105308-1106
			105308-1107	105308-1108	105308-2101	105308-2103	105308-2104
			105308-2105	105308-2106	105308-2107	105308-2108	
		105307	105307-1202	105307-1203	105307-1204	105307-1205	105307-1206
			105307-1207	105307-1208	105307-2202	105307-2203	105307-2204
			105307-2205	105307-2206	105307-2207	105307-2208	
		105308	105308-1202	105308-1203	105308-1204	105308-1205	105308-1206
			105308-1207	105308-1208	105308-2202	105308-2203	105308-2204
			105308-2205	105308-2206	105308-2207	105308-2208	

### DESCRIPTION:

This extractor tool is 57.3 mm (2.26 in.) long by 6.35mm (.25 in.) diameter, and weight about 0.03kg (1 oz.). See Figure 1.

#### TPA Latch

Before terminals can be extracted the TPA latch must be opened first on Nano-Fit™ power connectors that have the TPA feature see chart above.

- Using a small screwdriver insert the flat edge under the tab of the TPA lock. See Figure 2.
- Pull up and push out towards the crimped wire.
- Repeat this on the opposite side of the TPA lock. The TPA lock should be removed completely from the power connector.

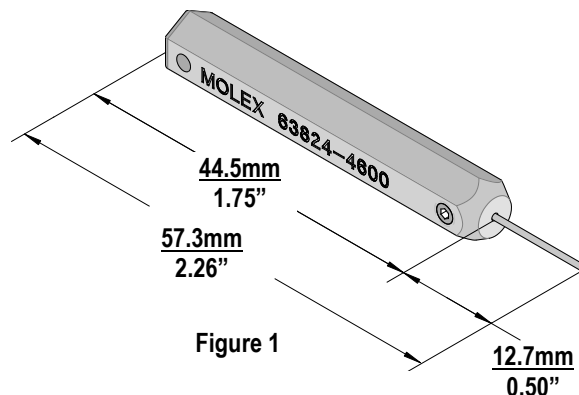

Figure 1

**OPERATION:**

When removing a damaged crimped wire from the Nano-Fit™ power connector follow the steps below:

1. Position the blade of the extraction tool into the slot (in line with the crimped terminal to be removed) in the front face of the housing as shown in Figure 3.

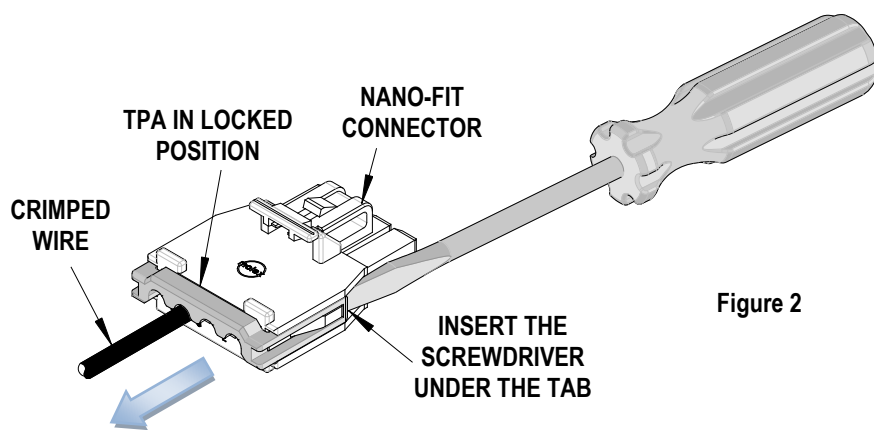

Figure 2

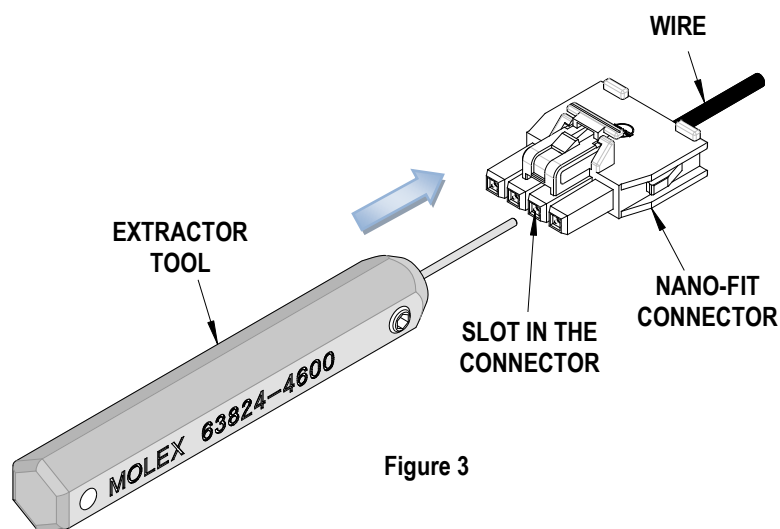

Figure 3

2. Push the terminal forward in the arrow direction before using the Extractor Tool as shown in Figure 4.
3. Insert the Extractor Tool into the slot of the connector housing. Push extractor tool into the slot until it clicks or comes to a stop. Do not force the extractor tool any farther, otherwise it may damage the housing.
4. Depress the terminal tang and push the terminal back through the connector slot.

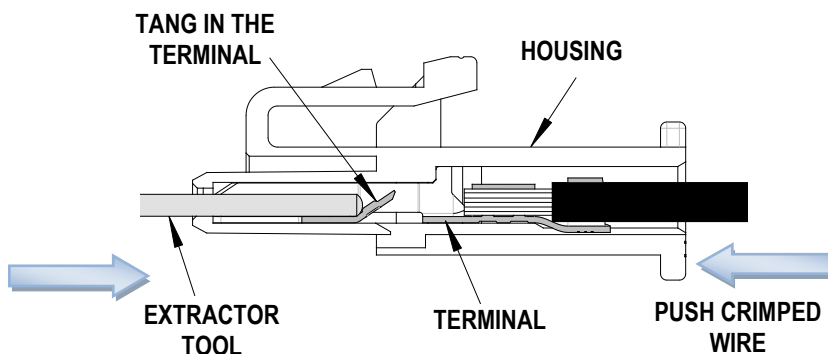

Figure 4



5. Holding the extractor tool against the housing, gently pull the crimped wire out of the connector. See Figure 5.

**NOTE:**

When a terminal is removed in this manner the locking tangs are damaged and the terminal is not reusable.

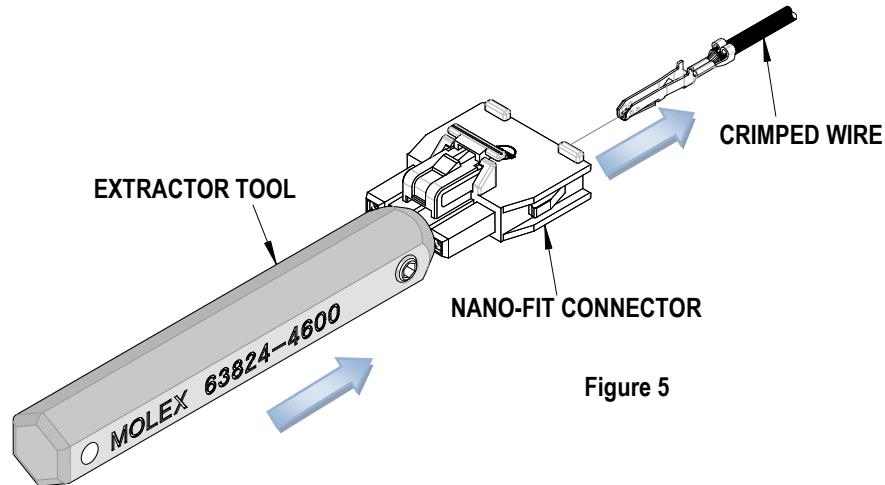

Figure 5

**CAUTION:** This extractor tool should be used to extract the terminal or seal cap only. Using it for unintended purposes may cause injury or damage to parts. Be careful not to deform the end of the terminal. Avoid lifting the housing lock too high.

**CAUTION:** Molex specifications are valid only when used with Molex terminals, applicators and tooling.

Molex does not offer repair parts for Extractor Tools due to the inexpensive nature of these tools.

**Contact Information**

For more information on Molex application tooling please contact your nearest Molex location shown below.

Visit our Web site at <http://www.molex.com>