



Chipsmall Limited consists of a professional team with an average of over 10 year of expertise in the distribution of electronic components. Based in Hongkong, we have already established firm and mutual-benefit business relationships with customers from,Europe,America and south Asia,supplying obsolete and hard-to-find components to meet their specific needs.

With the principle of “Quality Parts,Customers Priority,Honest Operation,and Considerate Service”,our business mainly focus on the distribution of electronic components. Line cards we deal with include Microchip,ALPS,ROHM,Xilinx,Pulse,ON,Everlight and Freescale. Main products comprise IC,Modules,Potentiometer,IC Socket,Relay,Connector.Our parts cover such applications as commercial,industrial, and automotives areas.

We are looking forward to setting up business relationship with you and hope to provide you with the best service and solution. Let us make a better world for our industry!



## Contact us

Tel: +86-755-8981 8866 Fax: +86-755-8427 6832

Email & Skype: info@chipsmall.com Web: www.chipsmall.com

Address: A1208, Overseas Decoration Building, #122 Zhenhua RD., Futian, Shenzhen, China





Extractor Tool

## Application Tooling Specification Sheet

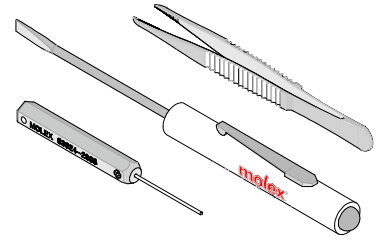

Order No. 63824-6300

### FEATURES

- The 63824-6300 Tool Kit is used on MXP120 Sealed Connection System. See below.

### SCOPE

**Products:** The Molex 1.2 sealed system is a series of connectors with 1x2, 1x3, 1x4, and 1x6, terminal configurations, designed to be used with Tyco 1.2 MCON terminals or Kostal MLK 1.2 terminals.

Terminal No.	Wire Size	Description	Housing Series	
<b>Tyco 1.2 MCON</b>				
1452665-3	0.25 - 0.35mm <sup>2</sup>	MCON-1.2 LL (Locking- Lance) Receptacle	34900	Female
1452668-3	0.50 - 0.75mm <sup>2</sup>	MCON-1.2 LL (Locking- Lance) Receptacle	34900	Female
2141114-3	0.25 - 0.35mm <sup>2</sup>	MCON-1.2 CB (Clean- Body) Blade	34899	Male
2141116-3	0.50 - 0.75mm <sup>2</sup>	MCON-1.2 CB (Clean- Body) Blade	34899	Male
2177610-3	0.75 - 1.0mm <sup>2</sup>	MCON-1.2 CB (Clean-Body) Blade	34899	Male
<b>Kostal MLK 1.2</b>				
32124734110	0.35mm <sup>2</sup>	MLK-1.2mm Single wire seal LL (Locking- Lance) Receptacle	34900	Female
32124734120	0.5mm <sup>2</sup>	MLK-1.2mm Single wire seal LL (Locking- Lance) Receptacle	34900	Female
32124734130	0.75 - 1.0mm <sup>2</sup>	MLK-1.2mm Single wire seal LL (Locking- Lance) Receptacle	34900	Female

### DESCRIPTION:

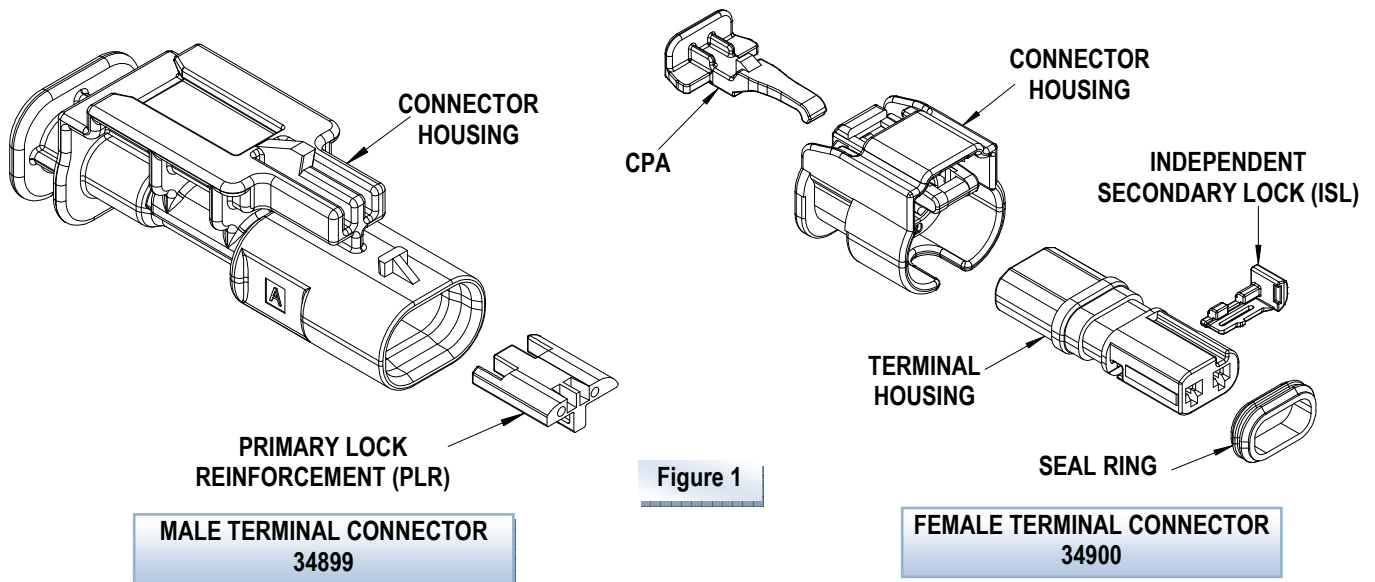

**Ordering Information**

Circuits Size	Series No.	Description	Sealed Assembly Cable Seal					
2 Circuit	34899	Male	34899-2010	34899-2011	34899-2012	34899-2013	34899-2020	34899-2021
			34899-2022	34899-2023	34899-2030	34899-2031	34899-2032	34899-2033
			34899-2040	34899-2041	34899-2042	34899-2043	34899-2050	34899-2060
			34899-2070	34899-2071	34899-2072	34899-2073	34899-2080	34899-2081
			34899-2082	34899-2083				
	34900	Female	34900-2001	34900-2002	34900-2003	34900-2004	34900-2020	34900-2021
			34900-2022	34900-2023	34900-2101	34900-2102	34900-2103	34900-2104
			34900-2120	34900-2121	34900-2122	34900-2123		
3 Circuit	34899	Male	34899-3010	34899-3011	34899-3012	34899-3013	34899-3020	34899-3021
			34899-3022	34899-3023	34899-3030	34899-3031	34899-3032	34899-3033
			34899-3040	34899-3041	34899-3042	34899-3043	34899-3050	34899-3060
			34899-3070	34899-3071	34899-3080	34899-3081	34899-3082	34899-3083
			34899-3090	34899-3091	34899-3092	34899-3093	34899-3110	34899-3111
			34899-3112	34899-3113	34899-3120	34899-3121	34899-3122	34899-3123
	34900	Female	34900-3001	34900-3002	34900-3003	34900-3004	34900-3020	34900-3021
			34900-3022	34900-3023	34900-3101	34900-3102	34900-3103	34900-3104
			34900-3120	34900-3121	34900-3122	34900-3123	34900-3124	34900-3125
			34900-3126	34900-3127				
4 Circuit	34899	Male	34899-4015	34899-4016	34899-4025	34899-4026	34899-4050	34899-4060
			34899-4070	34899-4071	34899-4072	34899-4073	34899-4074	34899-4075
			34899-4076	34899-4080	34899-4081	34899-4082	34899-4083	34899-4084
			34899-4085	34899-4086				
	34900	Female	34900-4010	34900-4011	34900-4012	34900-4013	34900-4014	34900-4015
			34900-4016	34900-4020	34900-4021	34900-4022	34900-4023	34900-4024
			34900-4025	34900-4026	34900-4110	34900-4111	34900-4112	34900-4113
			34900-4114	34900-4115	34900-4116	34900-4120	34900-4121	34900-4122
			34900-4123	34900-4124	34900-4125	34900-4126	34900-4130	34900-4131
			34900-4132	34900-4133	34900-4134	34900-4135	34900-4136	34900-4142
6 Circuit	34899	Male	34899-6010	34899-6011	34899-6012	34899-6013	34899-6020	34899-6021
			34899-6022	34899-6023	34899-6040	34899-6041	34899-6042	34899-6043
			34899-6050	34899-6060	34899-6061	34899-6062	34899-6063	34899-6070
			34899-6080	34899-6081	34899-6082	34899-6083	34899-6090	34899-6091
			34899-6092	34899-6093	34899-6110	34899-6111	34899-6112	34899-6113
			34899-6120	34899-6121	34899-6122	34899-6123		
	34900	Female	34900-6010	34900-6011	34900-6012	34900-6013	34900-6019	34900-6021
			34900-6028	34900-6030	34900-6040	34900-6041	34900-6042	34900-6043
			34900-6110	34900-6111	34900-6112	34900-6113	34900-6119	34900-6121
			34900-6128	34900-6130	34900-6140	34900-6141	34900-6142	34900-6143
			34900-6144	34900-6148				

## OPERATION:

### Separating the Male from the Female Connector

1. Disengage the CPA by pulling back as shown in Figure 2.

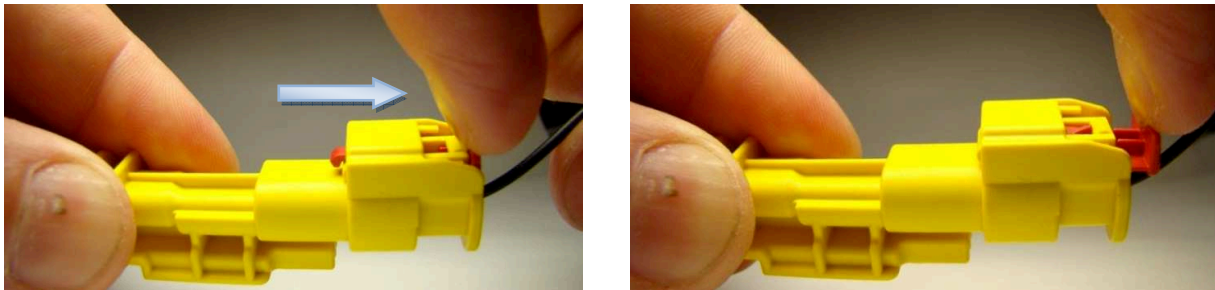

Figure 2

2. Push the connector halves together to unload the pressure on the latch system.
3. Depress the CPA latch with your thumb and hold it down while gently pulling the connector halves apart. See Figure 3.

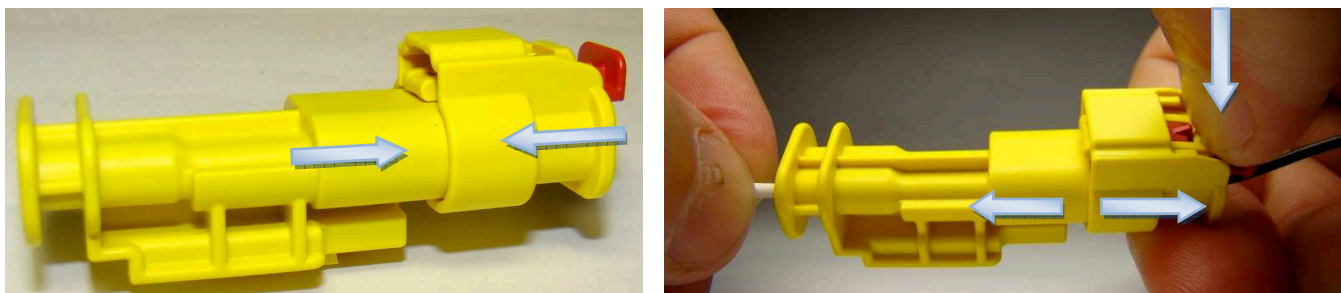



Figure 3

### Removing the Terminal

#### Male Connector

When removing damaged crimp wires the PLR on the male connector will need to be opened first.

1. To open the Primary Lock Reinforcement (PLR) use the serrated tip of the tweezers in the tool kit.
2. Grip the center rib feature of the PLR and pull the PLR out just enough so that the locking latches are visible (open position).  **Do not remove the PLR.** See Figure 4 and 5.

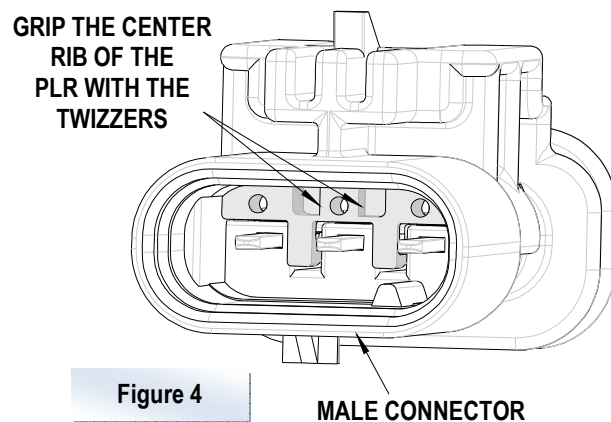
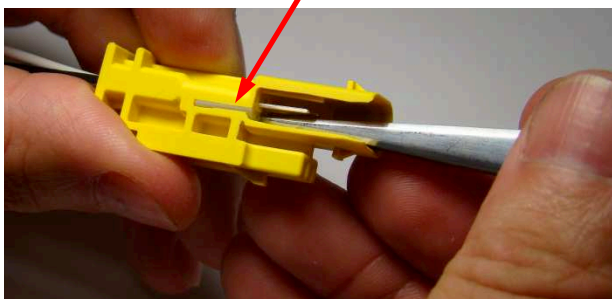

Figure 4

MALE CONNECTOR

PLR IN LOCKED POSITION



PLR IN OPEN POSITION

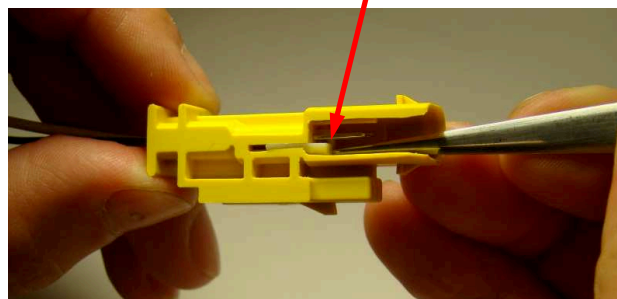

Figure 5

**OPERATION:**

When removing a damaged crimped terminal from the 1.2mm sealed male housing follow the steps below:

1. Using the 63824-2900 tool, position the extraction tool blade into the small hole (in line with the terminal to be removed) in the PLR. See Figure 6.
2. Push the crimped wire forward in the arrow direction before using the Extractor Tool.
3. Continue to push the extractor tool into the small hole until it clicks or comes to a stop.
4. This should separate the latch from the terminal. Do not force the extractor tool any farther, otherwise it may damage the housing.
5. Holding the extractor tool against the housing, gently pull the crimped wire out of the connector. See Figure 7.

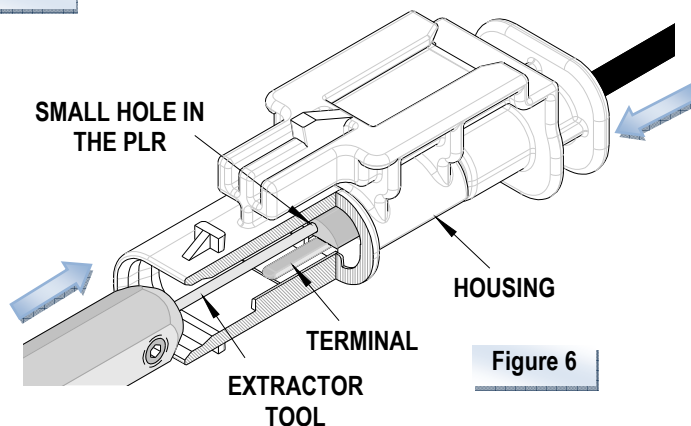

Figure 6

LATCH IN THE LOCKED POSITION

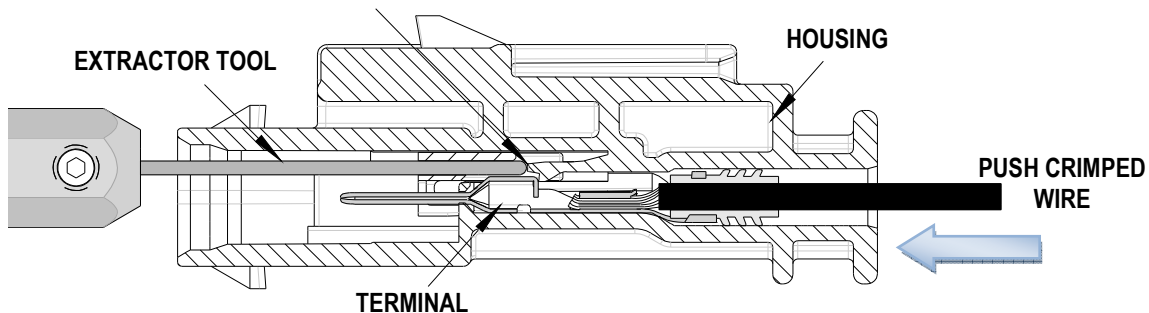
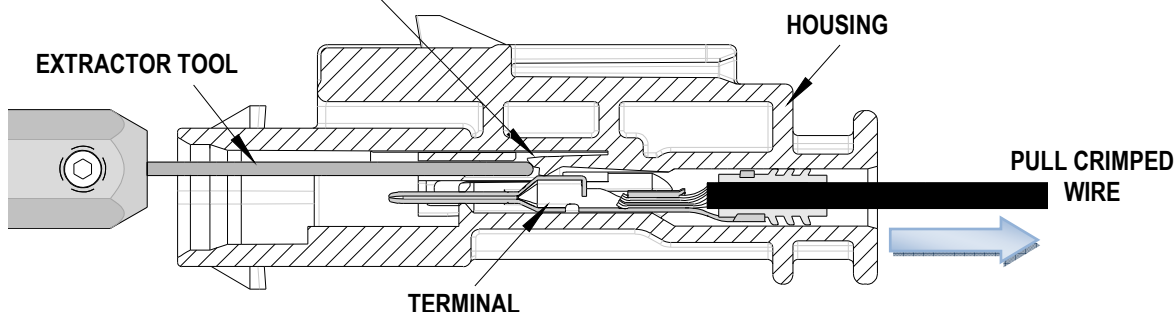

Figure 7

LATCH IN THE UNLOCKED POSITION



**CAUTION:** This extractor tool should be used to extract the terminal only. Using it for unintended purposes may cause injury or damage to parts. Be careful not to deform the end of the terminal.

### Female Connector

When removing damaged crimp wires the Independent Secondary Lock (ISL) on the female connector will need to be opened first.

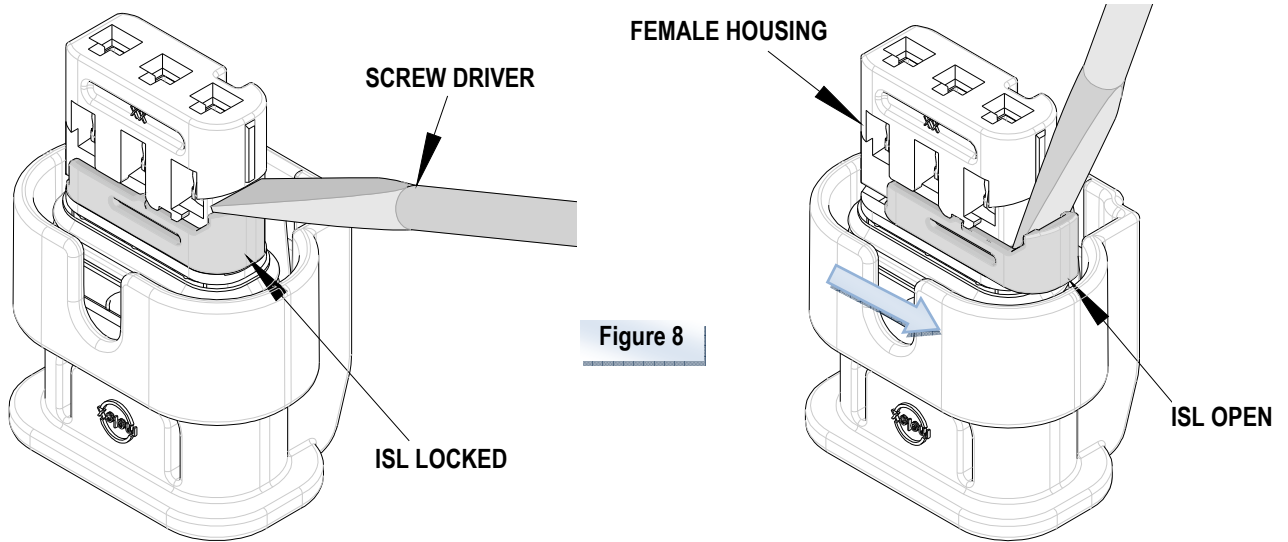

Figure 8

6. Using the Molex 63600-4398 Screwdriver in the tooling kit, insert the flat edge under the lip of the female housing and under the top edge of the ISL. See Figure 8.
7. Using the blade of the screwdriver gently slide the ISL out until it comes to a stop. **⚠ Do not remove the ISL.**

### OPERATION:

When removing a damaged crimped terminal from the 1.2mm sealed female housing follow the steps below:

1. Push the crimped wire forward in the arrow direction before using the Extractor Tool.
2. Using the 63824-2900 tool, position the blade of the extraction tool into desired small slot (in line with the terminal to be removed) in the front face of the female housing as shown in Figure 9.

**⚠ WARNING:** Do not insert the blade of the extractor into the large slots the contact beam will be damaged.

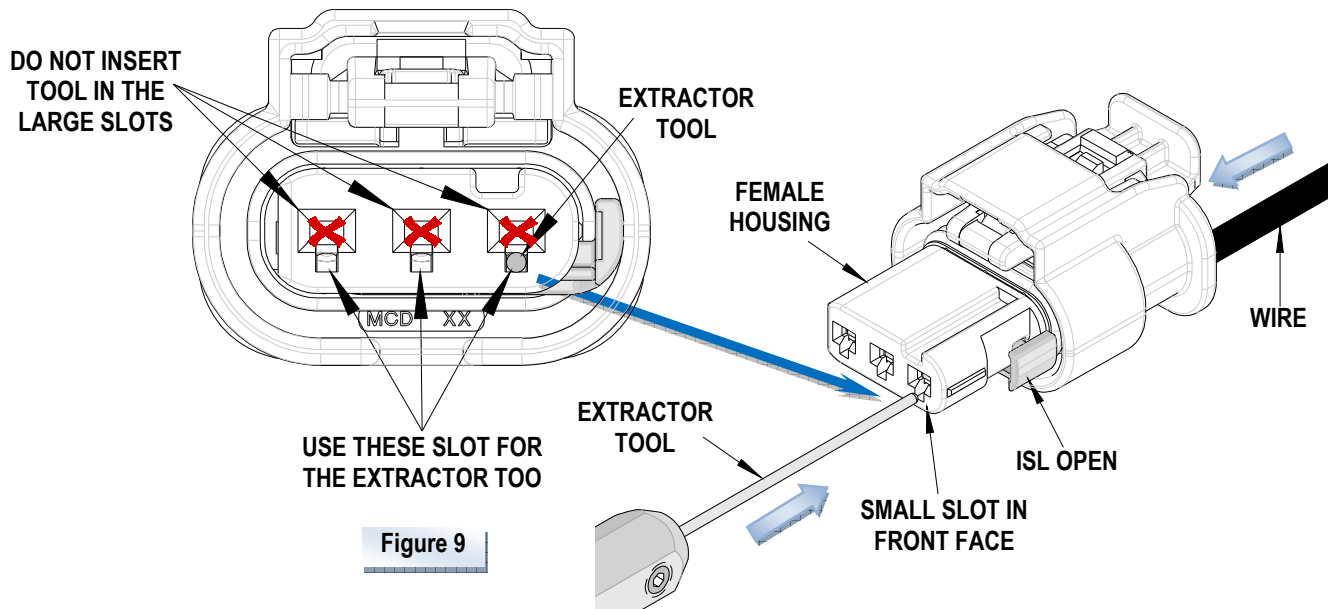
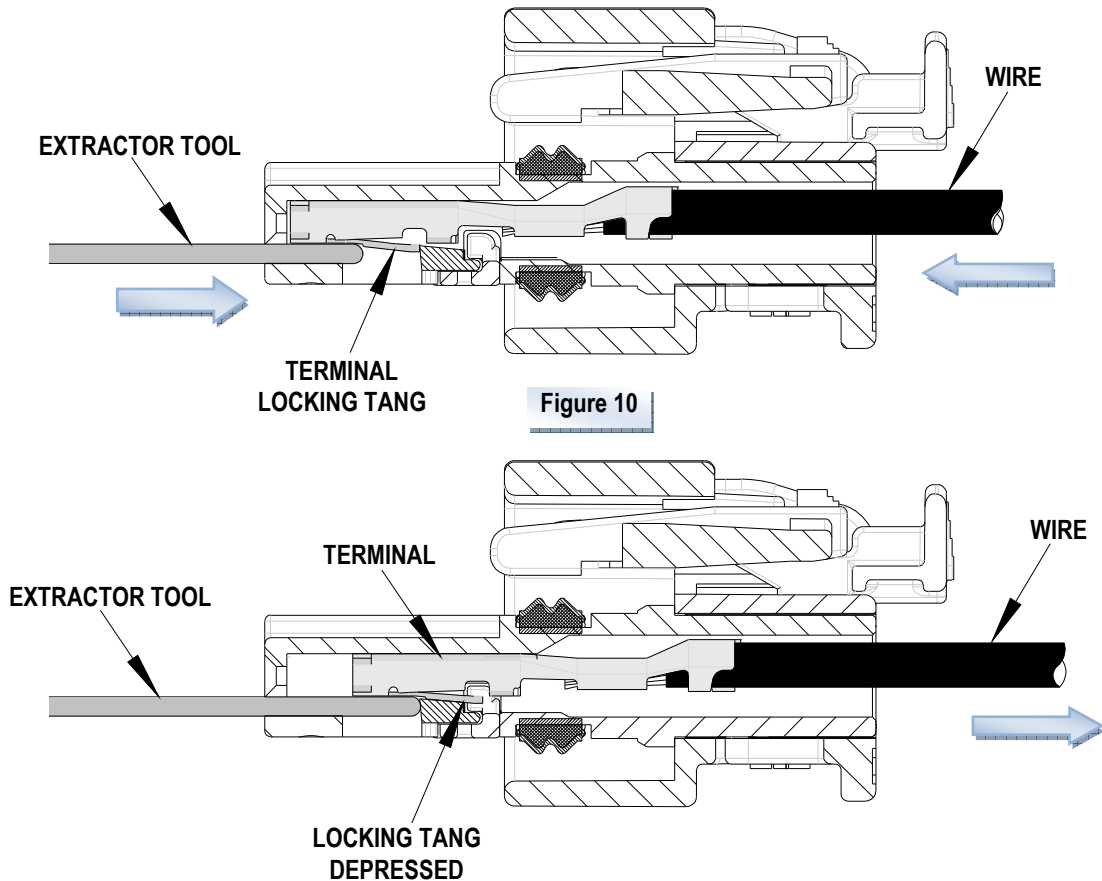

Figure 9

3. Continue to push the extractor tool into the small hole until it comes to a stop. Do not force the extractor tool any farther, otherwise it may damage the housing.
4. Depress the terminal locking tang and gently pull the terminal back through the connector slot in the arrow direction as shown in Figure 10.



**CAUTION:** This extractor tool should be used to extract the terminal only. Using it for unintended purposes may cause injury or damage to parts. Be careful not to deform the end of the terminal. Avoid lifting the housing lock too high.

**CAUTION:** Molex specifications are valid only when used with Molex terminals, applicators and tooling.

Molex does not offer repair parts for Extractor Tools due to the inexpensive nature of these tools.

**Application Tooling Support**  
2200 Wellington Court  
Lisle, IL 60532 USA  
Phone: +1-402-458-TOOL (8665)  
E-mail: [applicationtooling@molex.com](mailto:applicationtooling@molex.com)

Visit our Website at [www.molex.com/applicationtooling](http://www.molex.com/applicationtooling)