



Chipsmall Limited consists of a professional team with an average of over 10 year of expertise in the distribution of electronic components. Based in Hongkong, we have already established firm and mutual-benefit business relationships with customers from,Europe,America and south Asia,supplying obsolete and hard-to-find components to meet their specific needs.

With the principle of “Quality Parts,Customers Priority,Honest Operation,and Considerate Service”,our business mainly focus on the distribution of electronic components. Line cards we deal with include Microchip,ALPS,ROHM,Xilinx,Pulse,ON,Everlight and Freescale. Main products comprise IC,Modules,Potentiometer,IC Socket,Relay,Connector.Our parts cover such applications as commercial,industrial, and automotives areas.

We are looking forward to setting up business relationship with you and hope to provide you with the best service and solution. Let us make a better world for our industry!



Contact us

Tel: +86-755-8981 8866 Fax: +86-755-8427 6832

Email & Skype: info@chipsmall.com Web: www.chipsmall.com

Address: A1208, Overseas Decoration Building, #122 Zhenhua RD., Futian, Shenzhen, China



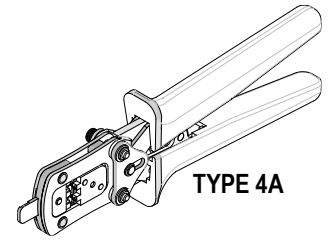
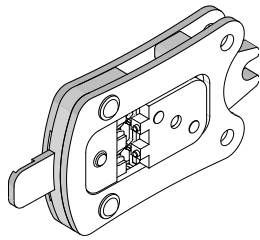

Modular Crimp Head
Order No. 63827-5770

Application Tooling Specification Sheet

Hand Crimp Tool
Order No. 63827-5700

FEATURES

- % A full cycle ratcheting hand tool ensures complete crimps
- % Ergonomically designed soft handles
- % Precisely designed crimping profiles with simple contact positioning
- % Easy handling due to outstanding force ratio
- % Modular Crimp Head is removable and can be use in the Air Powered Tool Order No.63816-0100, accompanied by Air Powered Crimp Adapter (Order No. 63816-0700).
- % Can also be used in the Battery Powered Tool Order No.63816-0200 (110 V) or 63816-0250 (220 V), accompanied by Battery Powered Crimp Adapter (Order No. 63816-0600).

SCOPE

Products: 1.00mm Pitch Pico-Lock™ Crimp Terminal, Reel, AWG 28-30.

Terminal Series No.	Terminal Order No.	Wire Size		♦Insulation Diameter				Strip Length	
				IPC/WHMA-A620 (2)		Terminal			
				Reel Form only (1)	AWG	mm ²	mm	In.	mm
503765	503765-0098	28	0.050	---	---	0.50-0.70	.020-.028	0.9-1.3	.035-.051
		30	0.079	0.60 Max.	.024 Max.	0.50-0.70	.020-.028		

(1) Customer to cut off terminal from reel: 0.05mm (.002") maximum Cut-off Tab
 (2) To achieve optimum IPC-A620 Class 2 insulation crimps, use this insulation OD.

DEFINITION OF TERMS

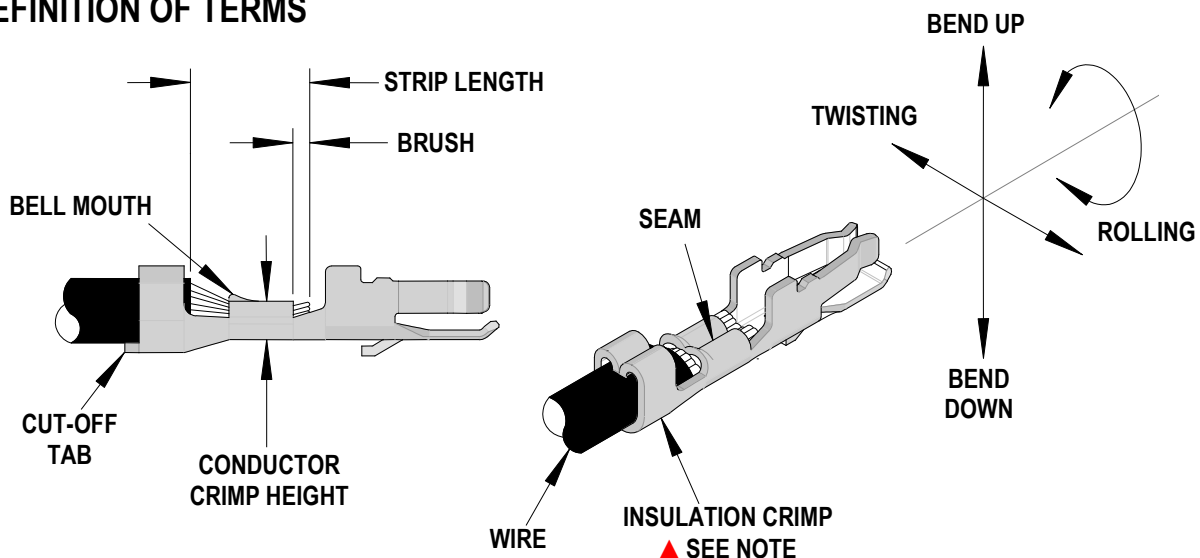

▲ Insulation Crimp Note:

Due to the terminal’s insulation grip design and/or insulation diameter range, this tool uses “overlap” form geometry in the insulation punch. While the insulation punch profile may appear “lopsided”, this is a normal condition for this tool. See figure to the right. (Some tools with multiple crimp pockets may not have the “overlap” profile on all pockets).

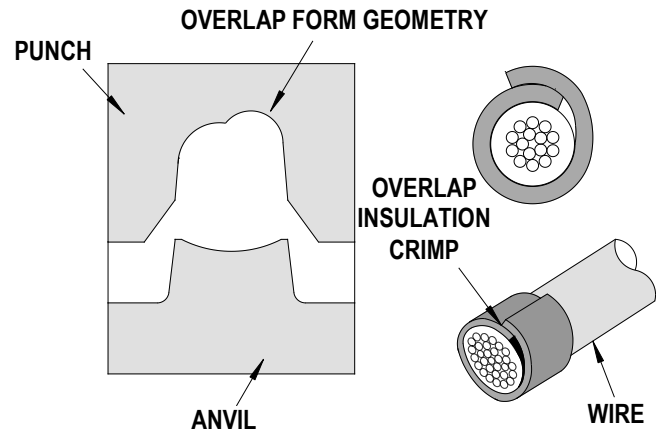

Crimp Specification

Terminal Series	Bell mouth		Conductor Brush		Bend up	Bend Down	Twist	Roll
	mm	In	mm	In				
503765	0.05-0.15	.002-.006	0.10-0.40	.004-.016	3°	2°	2°	3°

After crimping, the conductor profiles should measure the following.

Terminal Series	Wire Size		Conductor Crimp				Insulation Crimp Max.				Pull Force		Profile	
			Height		Width (Ref.)		Height (Ref.)		Width (Ref.)		Minimum		28	30
	AWG	mm ²	mm	In.	mm	In.	mm	In.	mm	In.	N	Lb.		
503765	28	0.050	0.42-0.46	.016-.018	0.72	.028	0.90	.035	0.86	.034	9.8	2.20	X	
	30	0.079	0.38-0.42	.015-.017	0.72	.028	0.80	.031	0.80	.031	4.9	1.10		X

Tool Qualification Notes:

1. Pull Force should be measured with no influence from the insulation crimp.
2. The above specifications are guidelines to an optimum crimp.

Notes:

1. This tool should only be used for the terminals and wire gauges specified on this sheet.
2. This tool is not adjustable for crimp height. Variations in tools, terminals, wire stranding, and insulation types may affect crimp height.
3. This tool is intended for AWG conductors. It may not give a good insulation crimp support for other insulation styles.
4. Molex does not repair hand tools (see *Warranty* on page 3). The replacement parts listed are the only parts available for repair. If the handles or crimp tooling is damaged or worn, a new tool must be purchased.
5. Pull force should be used as the final criteria for an acceptable crimp. Refer to Molex Quality Crimping Handbook 63800-0029 for additional information on crimping and crimp testing.
6. Molex does not certify crimp hand tools.

OPERATION

Open the tool by squeezing the handles together, at the end of the closing stroke, the ratchet mechanism will release the handles, and the hand tool will spring open.

Preparing Terminals for Crimping

Singulate the terminal by cutting it from the reel along with the carrier strip which includes the carrier strip hole. See Figure 1. The carrier strip hole is used to assist in loading the terminal in position over the crimp anvils. The carrier strip will help maintain terminal position during crimping.

For loading Terminals

It is recommended that a magnification such as an eye loop and tweezers be used due to the size of the terminal.

Crimping Terminals

1. Load the terminal with carrier strip into the proper crimp profile. Make sure the carrier strip **pilot hole** fits over the positioning pin and the end of the terminal is inserted in the hand tool slot. See Figure 1.
2. Push the wire stop downward (into the tool frame).
3. Place the properly stripped wire into the open terminal barrel. Push the wire into the tool until the end of the wire contacts the wire stop, making sure that all wire strands are inside of the conductor barrel. See Figures 2 and 3.
4. While holding the wire with one hand, slowly squeeze the tool handles together to close the tool jaws until the ratchet mechanism releases. At this point the handles can be released and will spring open.
5. Remove the crimped terminal and remove the carrier strip by gently flexing back and forth to break it free and dispose of it.
6. Inspect the crimped wire for acceptable crimp specifications.

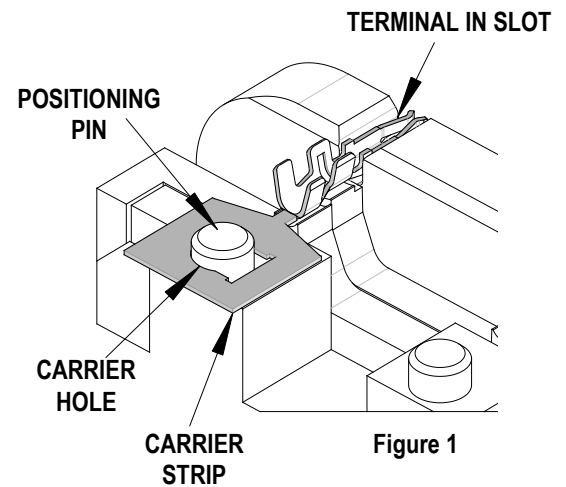

Figure 1

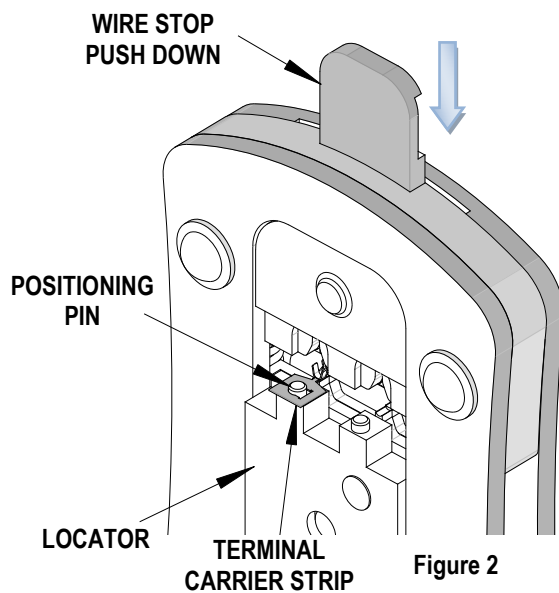

Figure 2

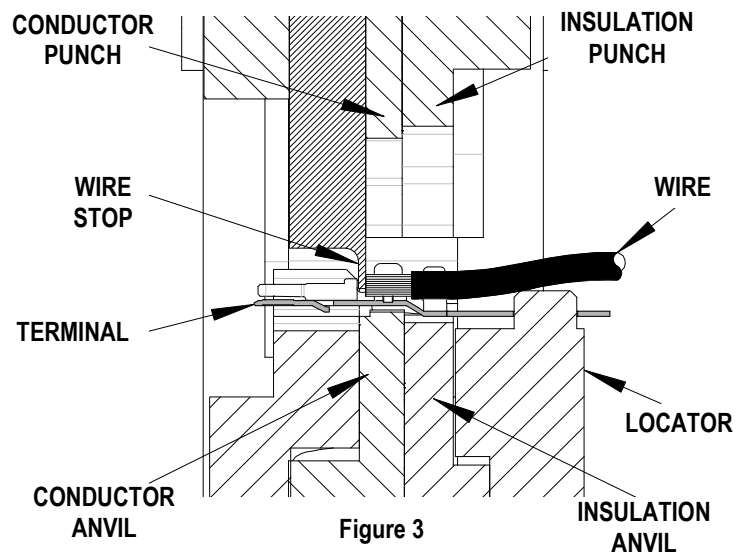

Figure 3

Note: The ratchet mechanism will not release the tool until it has been fully closed.

Maintenance

It is recommended that each operator of the tool be made aware of, and responsible for, the following maintenance steps:

1. Remove dust, moisture, and other contaminants with a clean brush, or soft, lint free cloth.
2. Do not use any abrasive materials that could damage the tool.
3. Make certain all pins; pivot points and bearing surfaces are protected with a thin coat of high quality machine oil. Do not oil excessively. The tool was engineered for durability but like any other equipment it needs cleaning and lubrication for a maximum service life of trouble free crimping. Light oil (such as 30 weight automotive oil) used at the oil points, every 5,000 crimps or 3 months, will significantly enhance the tool life.

4. Wipe excess oil from hand tool, particularly from crimping area. Oil transferred from the crimping area onto certain terminations may affect the electrical characteristics of an application.
5. When tool is not in use, keep the handles closed to prevent objects from becoming lodged in the crimping dies, and store the tool in a clean, dry area.

Miscrimps or Jams

Should this tool ever become stuck or jammed in a partially closed position, **Do Not force the handles open or closed**. The tool will open easily by lifting the ratchet release lever. See Figure 6.

Warranty

This tool is for electrical terminal crimping purposes only. This tool is made of the best quality materials. All vital components are long life tested. All tools are warranted to be free of manufacturing defects for a period of 30 days. Should such a defect occur, we will repair or exchange the tool free of charge. This repair or exchange will not be applicable to altered, misused, or damaged tools. This tool is designed for hand use only. Any clamping, fixturing, or use of handle extensions voids this warranty.

CAUTION: Repetitive use of this tool should be avoided.

CAUTIONS:

1. Manually powered hand tools are intended for low volume or field repair. This tool is **NOT** intended for production use. Repetitive use of this tool should be avoided.
2. Insulated rubber handles are not protection against electrical shock.
3. Wear eye protection at all times.
4. Use only the Molex terminals specified for crimping with this tool.

CAUTION: Molex crimp specifications are valid only when used with Molex terminals and tooling.

Applications for the Modular Crimp Head

WARNING: NEVER operate, service, install, or adjust this Modular Crimp Head without proper instruction and without first reading and understanding the instructions in the proper Manual or Specification Sheet. See Chart below for the correct Manual or Specification Sheet.

WARNING: NEVER install tooling or service this tool while it is into any power source. Disconnect the power by unplugging or turn off the Actuator from its power source.

CAUTION: Keep fingers away from the crimping area when operating this tool. It may cause severe injury.

CAUTION: Wear safety glasses when operating or serving this tool.

The chart below shows all applications for this Modular Crimp Head.

Modular Crimp Head Order No.	Tool Order no.	Tool Description	Adapter Order No.	Adapter Description	Figure No.
63827-5770	63816-0000	Hand Crimp Frame (Short)	N/A	N/A	3
	63816-0050	Hand Crimp Frame (Long)	N/A	N/A	3
	63816-0200	Battery Power Tool (110 V)	63816-0600	Battery Power Crimp Adapter	4
	63816-0250	Battery Power Tool (220 V)	63816-0600	Battery Power Crimp Adapter	4
	63816-0100	Air Power Tool	63816-0700	Air Power Crimp Adapter	5

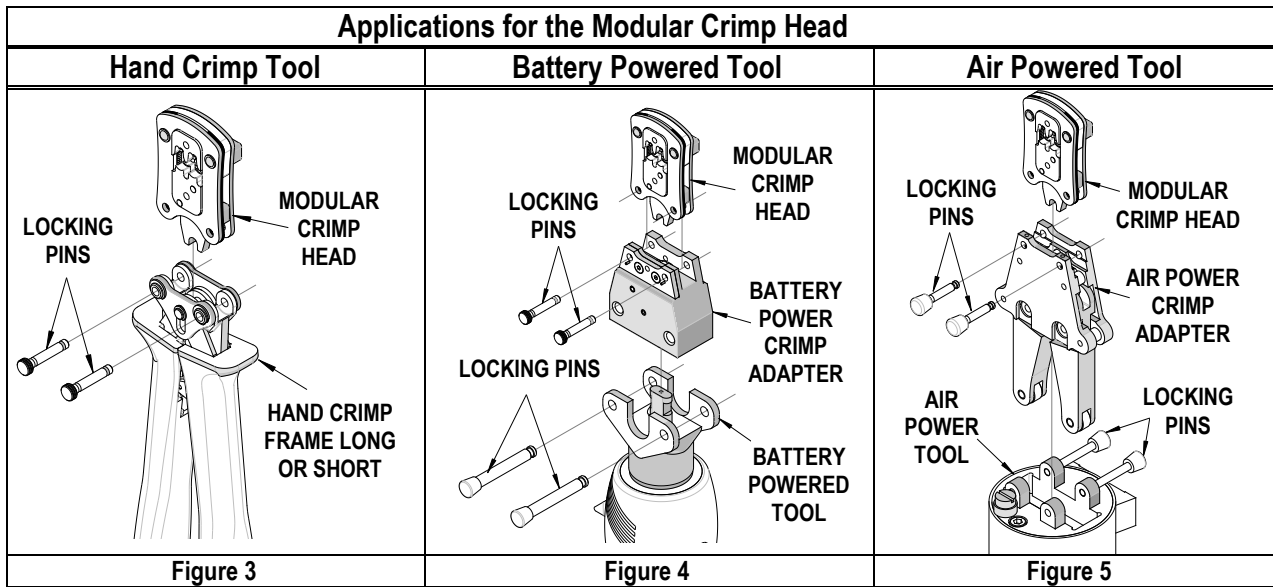

PARTS LIST

Item	Order Number	Description	Quantity
1	63827-5770	Modular Crimp Head	1 (Ref)
2	63816-0000	Hand Crimp Frame (Short)	1 (Ref)
3	63827-5775	Locator Plate	1
4	63816-0001	Locking Pin	2
5	63600-0525	Handle Spring	1
6	63600-0520	Crimping Spring	2

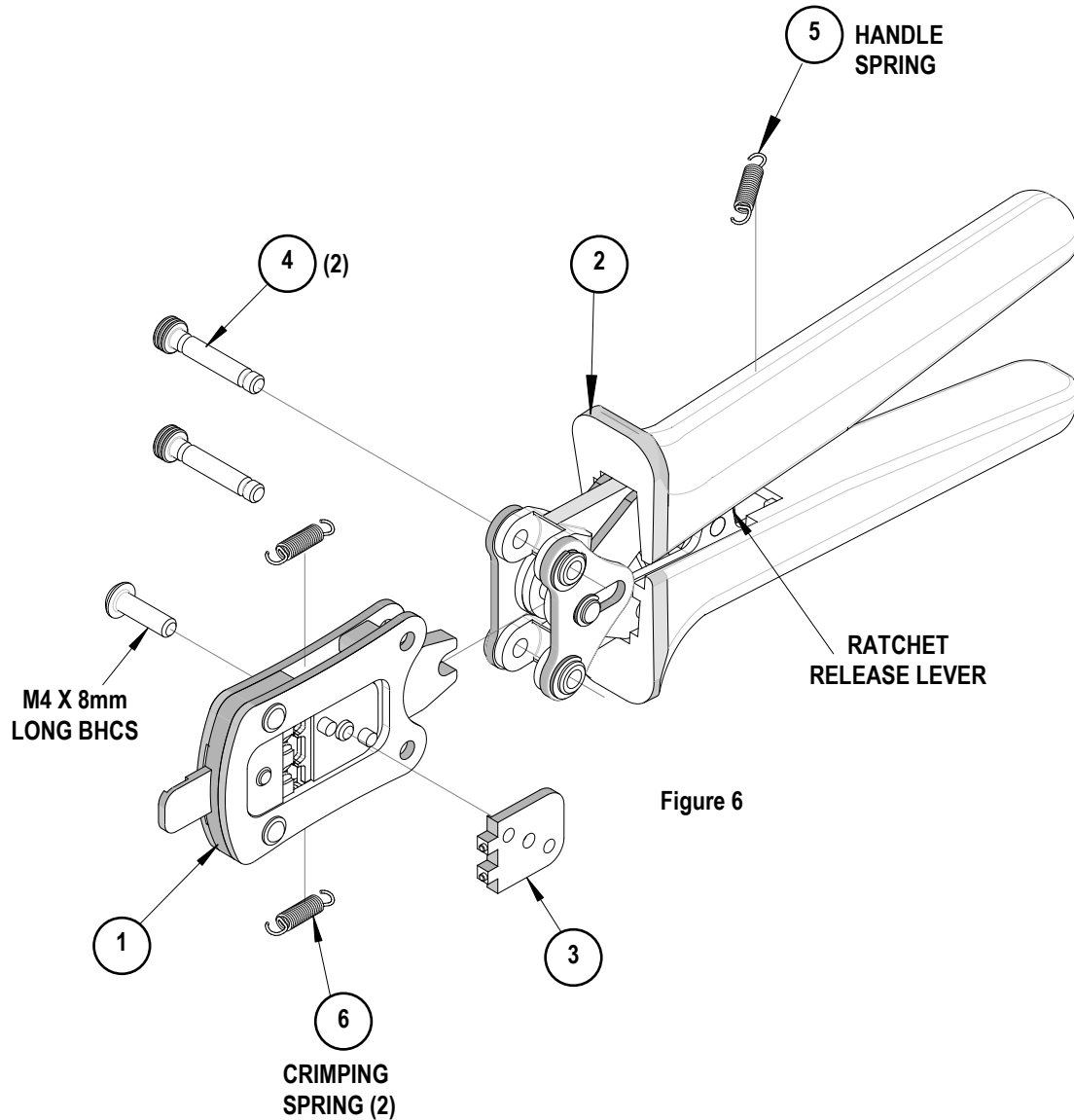

Visit our Web site at <http://www.molex.com>