



Chipsmall Limited consists of a professional team with an average of over 10 year of expertise in the distribution of electronic components. Based in Hongkong, we have already established firm and mutual-benefit business relationships with customers from,Europe,America and south Asia,supplying obsolete and hard-to-find components to meet their specific needs.

With the principle of “Quality Parts,Customers Priority,Honest Operation,and Considerate Service”,our business mainly focus on the distribution of electronic components. Line cards we deal with include Microchip,ALPS,ROHM,Xilinx,Pulse,ON,Everlight and Freescale. Main products comprise IC,Modules,Potentiometer,IC Socket,Relay,Connector.Our parts cover such applications as commercial,industrial, and automotives areas.

We are looking forward to setting up business relationship with you and hope to provide you with the best service and solution. Let us make a better world for our industry!



## Contact us

Tel: +86-755-8981 8866 Fax: +86-755-8427 6832

Email & Skype: info@chipsmall.com Web: www.chipsmall.com

Address: A1208, Overseas Decoration Building, #122 Zhenhua RD., Futian, Shenzhen, China



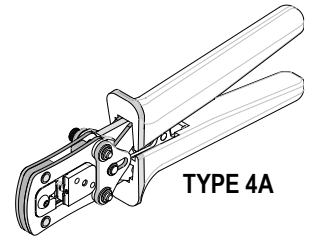
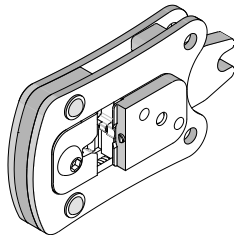

**Modular Crimp Head  
Order No. 63827-8470**

## Application Tooling Specification Sheet

**Hand Crimp Tool  
Order No. 63827-8400**

### FEATURES

- % A full cycle ratcheting hand tool ensures complete crimps
- % Ergonomically designed soft handles
- % Precisely designed crimping profiles with simple contact positioning
- % Easy handling due to outstanding force ratio
- % Modular Crimp Head is removable and can be use in the Air Powered Tool Order No.63816-0100, accompanied by Air Powered Crimp Adapter (Order No. 63816-0700).
- % Can also be used in the Battery Powered Tool Order No.63816-0200 (110 V) or 63816-0250 (220 V), accompanied by Battery Powered Crimp Adapter (Order No. 63816-0600).

### SCOPE

Products: Board-In Crimp Terminals, 22-26 AWG.

Terminal Series No.	Terminal Order No.	Wire Size		◆ Insulation Diameter (Max.)		▶ Strip Length	
		AWG	mm <sup>2</sup>	mm	In.	mm	In.
90198	90198-0001	22-26	NA	1.52	.060	1.70-2.10	.067-.083
<p><b>Terminal will accommodate the following wire specification:</b>                      22 AWG-Solid Wire or Fused Wire                      24-26 AWG Solid Wire, Fused Wire or Stranded Wire                      ◆ To achieve optimum IPC-A620 Class 2 insulation crimps, use this insulation OD range:                      22 AWG: 1.45-1.52 mm, 24 AWG: 1.02-1.15 mm, 26 AWG: 0.90-1.05 mm</p>							

### ▶ Strip Length

Check the insulation to ensure that there has been a nice clean cut. Wires with damaged insulation should not be used. See Figure 1.

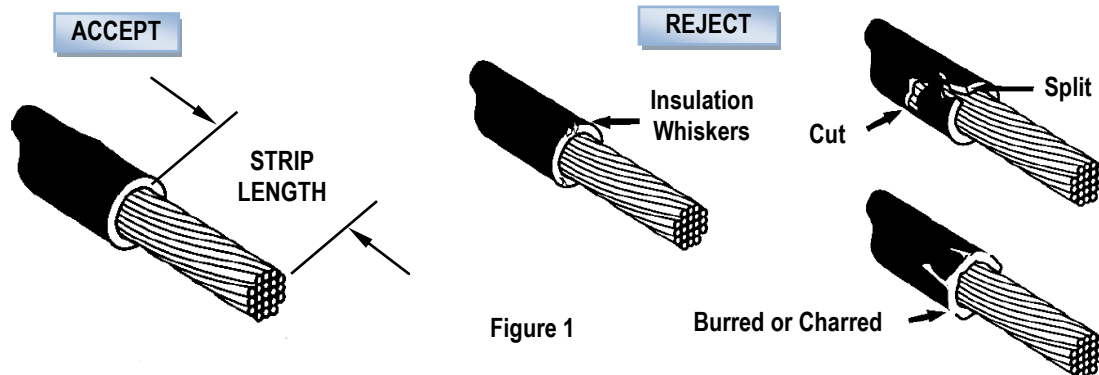
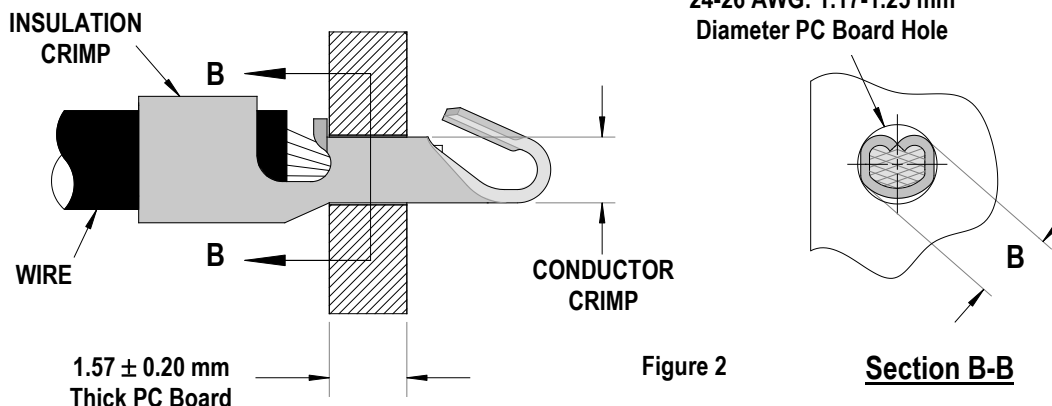

Figure 1

### DEFINITION OF TERMS



### CRIMP SPECIFICATIONS

After crimping, the conductor profiles should measure the following (See Figure 2).

Terminal Series No.	Wire Size		"A" Crimp Height (Ref.)		"B" Diagonal Dim. Maximum		♦ Pull Force Minimum	
	AWG	mm <sup>2</sup>	mm	In.	mm	In.	N	Lb.
90198	22	NA	0.89	.035	1.19	.047	35.6	8.0
	24	NA	0.79	.031	1.14	.045	22.2	5.0
	26	NA	0.74	.029	1.14	.045	13.3	3.0

Terminal Series No.	Wire Size		Insulation Crimp Height (Ref.)		Insulation Crimp Width (Ref.)		Profile		
	AWG	mm <sup>2</sup>	mm	In.	mm	In.	A	B	C
90198	22	NA	1.65	.065	1.75	.069	X		
	24	NA	1.55	.061	1.55	.061		X	
	26	NA	1.50	.059	1.55	.061			X

♦ The crimp on this terminal is not an electrical crimp; the final soldering operation is the electrical connection. This minimum pull force is what should be expected when pulling the terminal with both insulation and conductor crimped.

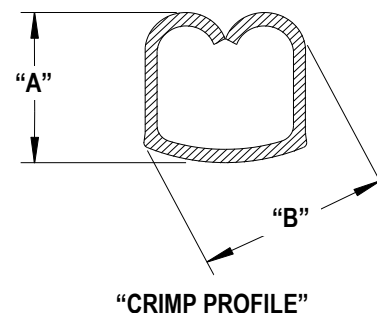

#### Tool Qualification Notes:

1. Pull Force should be measured with no influence from the insulation crimp.
2. The above specifications are guidelines to an optimum crimp.

#### Notes:

1. This tool should only be used for the terminals and wire gauges specified on this sheet.
2. This tool is not adjustable for crimp height. Variations in tools, terminals, wire stranding, and insulation types may affect crimp height.
3. Molex does not repair hand tools (see *Warranty* on page 4). The replacement parts listed are the only parts available for repair. If the handles or crimp tooling is damaged or worn, a new tool must be purchased.
4. Pull force should be used as the final criteria for an acceptable crimp. Refer to Molex Quality Crimping Handbook 63800-0029 for additional information on crimping and crimp testing.
5. Molex does not certify crimp hand tools.



## OPERATION

Open the tool by squeezing the handles together, at the end of the closing stroke, the ratchet mechanism will release the handles, and the hand tool will spring open.

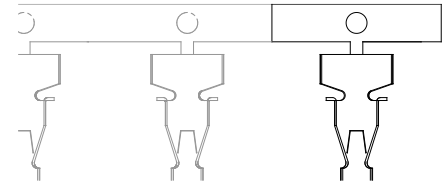

Figure 3

## Preparing Terminals for Crimping

The terminals must be cut from the reel as shown. See Figure 3. The carrier strip hole is used to assist in loading the terminal in position over the crimp anvils. The carrier strip will help maintain terminal position during crimping and can be broken off after the crimp is complete.

## Crimping Terminals

1. Load the terminal with carrier strip into the proper crimp profile. Make sure the carrier strip pilot hole fits over the positioning pin.
2. Place the properly stripped wire into the correct profile and above the terminal. Pull the wire up; make sure all the wire strands are captured inside the insulation stop/slot. Push the wire into the tool until the end of the insulation contacts the insulation stop. See Figures 4 and 5.
3. While holding the wire with one hand, slowly squeeze the tool handles together to close the tool jaws until the ratchet mechanism releases. At this point the handles can be released and will spring open.
4. Remove the crimped terminal and inspect for acceptable crimp attributes.

**Note:** The tamper proof ratchet action will not release the tool until it has been fully closed.

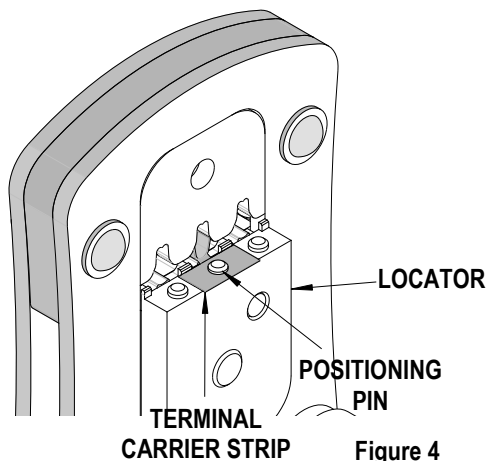

Figure 4

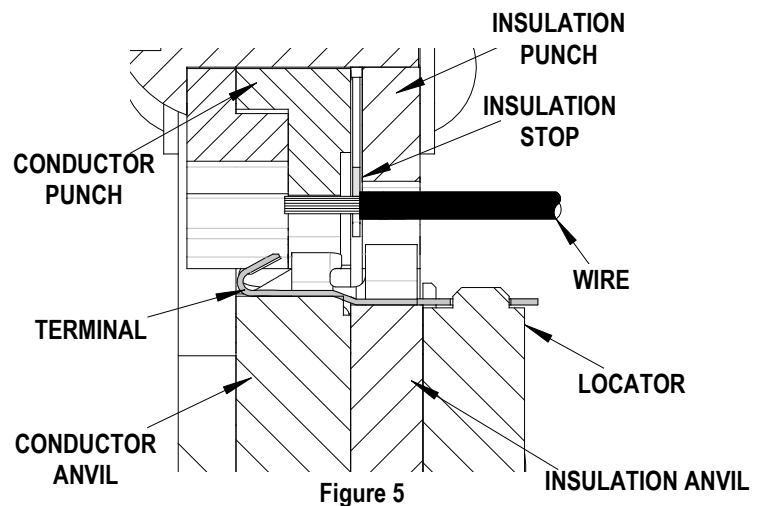

Figure 5

## Maintenance

It is recommended that each operator of the tool be made aware of, and responsible for, the following maintenance steps:

1. Remove dust, moisture, and other contaminants with a clean brush, or soft, lint free cloth.
2. Do not use any abrasive materials that could damage the tool.
3. Make certain all pins; pivot points and bearing surfaces are protected with a thin coat of high quality machine oil. Do not oil excessively. The tool was engineered for durability but like any other equipment it needs cleaning and lubrication for a maximum service life of trouble free crimping. Light oil (such as 30 weight automotive oil) used at the oil points, every 5,000 crimps or 3 months, will significantly enhance the tool life.

4. Wipe excess oil from hand tool, particularly from crimping area. Oil transferred from the crimping area onto certain terminations may affect the electrical characteristics of an application.
5. When tool is not in use, keep the handles closed to prevent objects from becoming lodged in the crimping dies, and store the tool in a clean, dry area.

### Miscrimps or Jams

Should this tool ever become stuck or jammed in a partially closed position, **Do Not force the handles open or closed**. The tool will open easily by lifting the ratchet release lever. See Figure 9.

### Warranty

This tool is for electrical terminal crimping purposes only. This tool is made of the best quality materials. All vital components are long life tested. All tools are warranted to be free of manufacturing defects for a period of 30 days. Should such a defect occur, we will repair or exchange the tool free of charge. This repair or exchange will not be applicable to altered, misused, or damaged tools. This tool is designed for hand use only. Any clamping, fixturing, or use of handle extensions voids this warranty.

**CAUTION: Repetitive use of this tool should be avoided.**

### CAUTIONS:

1. Manually powered hand tools are intended for low volume or field repair. This tool is **NOT** intended for production use. Repetitive use of this tool should be avoided.
2. Insulated rubber handles are not protection against electrical shock.
3. Wear eye protection at all times.
4. Use only the Molex terminals specified for crimping with this tool.

**CAUTION: Molex crimp specifications are valid only when used with Molex terminals and tooling.**

### Applications for the Modular Crimp Head

**WARNING: NEVER** operate, service, install, or adjust this Modular Crimp Head without proper instruction and without first reading and understanding the instructions in the proper Manual or Specification Sheet. See Chart below for the correct Manual or Specification Sheet.

**WARNING: NEVER** install tooling or service this tool while it is into any power source. Disconnect the power by unplugging or turn off the Actuator from its power source.

**CAUTION: Keep fingers away from the crimping area when operating this tool. It may cause severe injury.**

**CAUTION: Wear safety glasses when operating or serving this tool.**

The chart below shows all applications for this Modular Crimp Head.

Modular Crimp Head Order No.	Tool Order no.	Tool Description	Adapter Order No.	Adapter Description	Figure No.
63827-8470	63816-0000	Hand Crimp Frame (Short)	N/A	N/A	6
	63816-0050	Hand Crimp Frame (Long)	N/A	N/A	6
	63816-0200	Battery Power Tool (110 V)	63816-0600	Battery Power Crimp Adapter	7
	63816-0250	Battery Power Tool (220 V)	63816-0600	Battery Power Crimp Adapter	7
	63816-0100	Air Power Tool	63816-0700	Air Power Crimp Adapter	8

**Applications for the Modular Crimp Head**

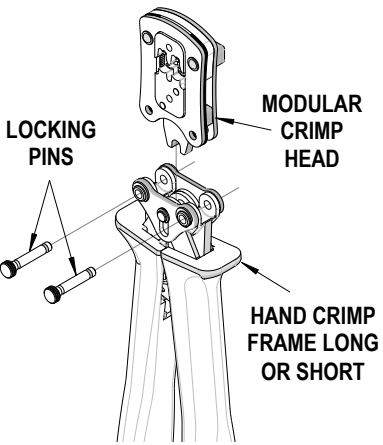
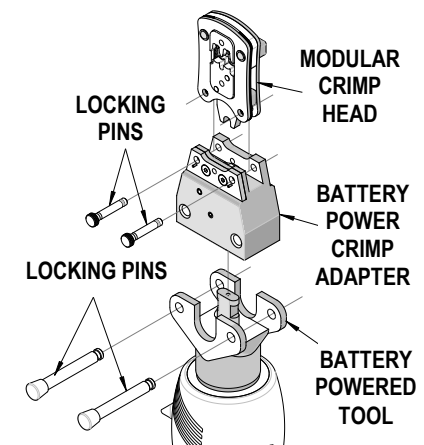
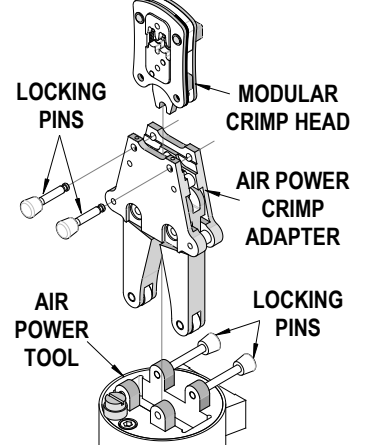
Hand Crimp Tool	Battery Powered Tool	Air Powered Tool
 <p>LOCKING PINS</p> <p>MODULAR CRIMP HEAD</p> <p>HAND CRIMP FRAME LONG OR SHORT</p>	 <p>LOCKING PINS</p> <p>MODULAR CRIMP HEAD</p> <p>BATTERY POWER CRIMP ADAPTER</p> <p>BATTERY POWERED TOOL</p> <p>LOCKING PINS</p>	 <p>LOCKING PINS</p> <p>MODULAR CRIMP HEAD</p> <p>AIR POWER CRIMP ADAPTER</p> <p>AIR POWER TOOL</p> <p>LOCKING PINS</p>
Figure 6	Figure 7	Figure 8

### PARTS LIST

Item	Order Number	Description	Quantity
1	63827-8470	Modular Crimp Head	1 (Ref)
2	63816-0000	Hand Crimp Frame (Short)	1 (Ref)
3	63827-8475	Locator Plate	1
4	63816-0001	Locking Pin	2
5	63600-0525	Handle Spring	1
6	63600-0520	Crimping Spring	2

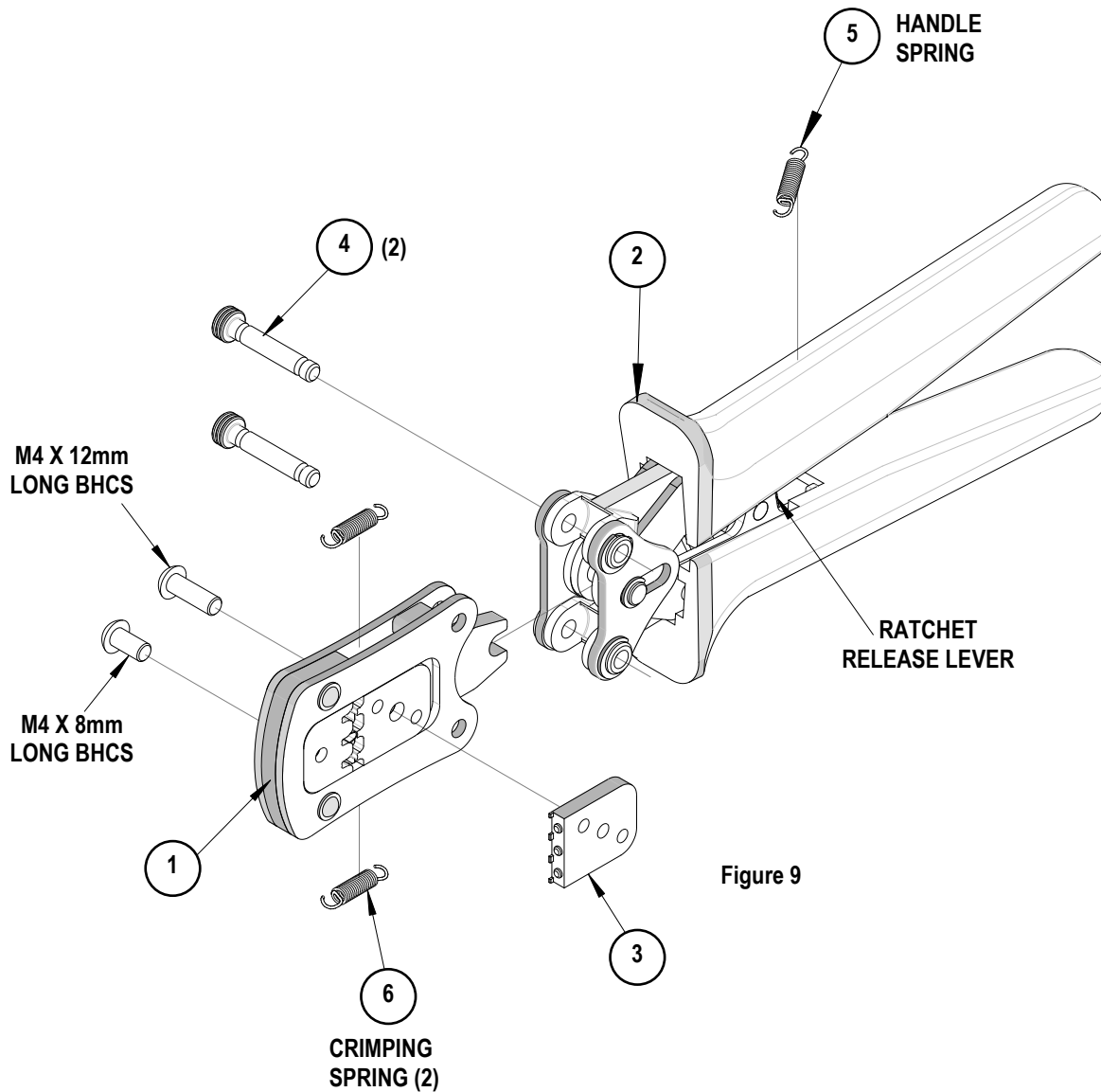

Visit our Web site at <http://www.molex.com>