



Chipsmall Limited consists of a professional team with an average of over 10 year of expertise in the distribution of electronic components. Based in Hongkong, we have already established firm and mutual-benefit business relationships with customers from,Europe,America and south Asia,supplying obsolete and hard-to-find components to meet their specific needs.

With the principle of “Quality Parts,Customers Priority,Honest Operation,and Considerate Service”,our business mainly focus on the distribution of electronic components. Line cards we deal with include Microchip,ALPS,ROHM,Xilinx,Pulse,ON,Everlight and Freescale. Main products comprise IC,Modules,Potentiometer,IC Socket,Relay,Connector.Our parts cover such applications as commercial,industrial, and automotives areas.

We are looking forward to setting up business relationship with you and hope to provide you with the best service and solution. Let us make a better world for our industry!



Contact us

Tel: +86-755-8981 8866 Fax: +86-755-8427 6832

Email & Skype: info@chipsmall.com Web: www.chipsmall.com

Address: A1208, Overseas Decoration Building, #122 Zhenhua RD., Futian, Shenzhen, China





SPECIFICATION SHEET
FineAdjust Applicator
63862-8000
REVISION A

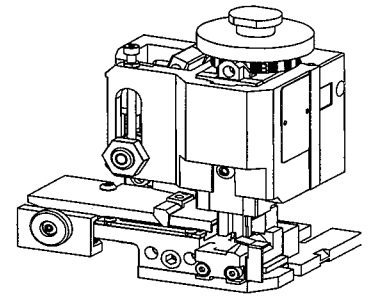

SCOPE

Terminal Series No	Wire Size		Insulation Diameter		Strip Length	
	Awg	(mm ²)	mm	(in)	mm	(in)
50372-8*00	22-26	(0.35-0.12)	0.95-1.40	(.037-.055)	1.30-1.80	(.051-.071)

DEFINITION OF TERMS

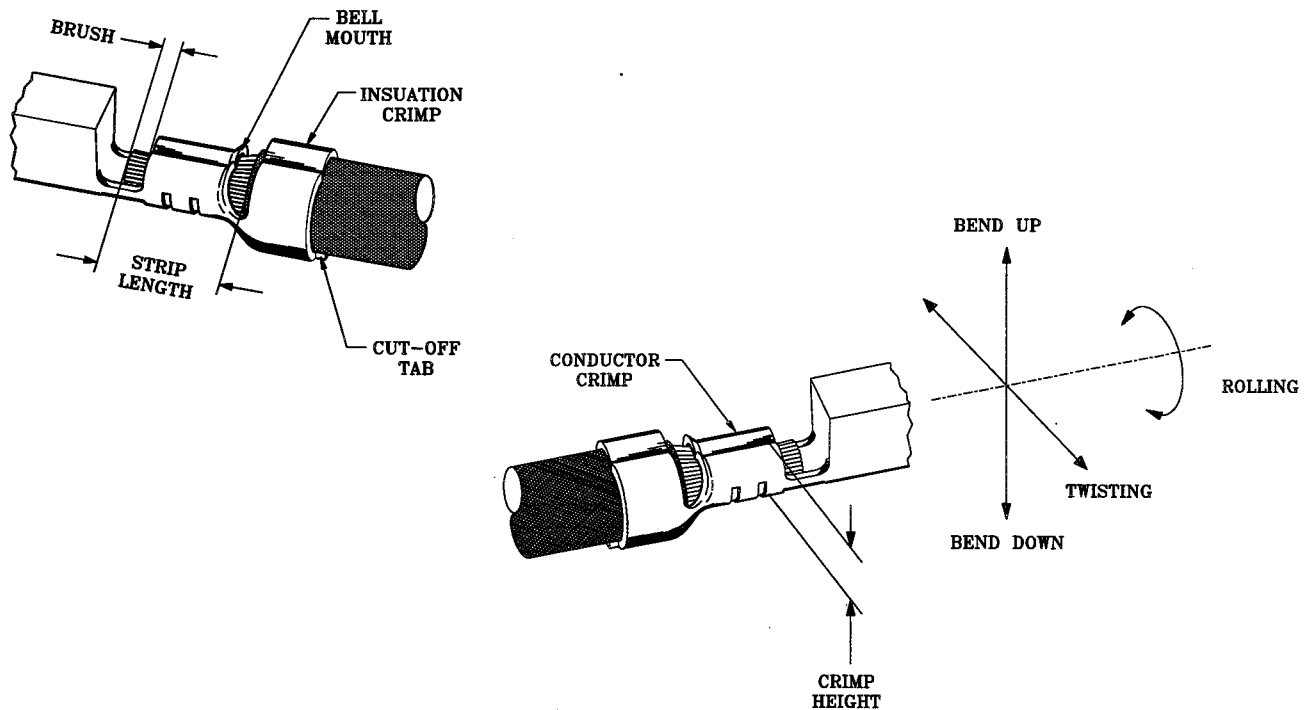

The above terminal drawing is a generic terminal representation. It is not an image of a terminal listed in the scope

SPECIFICATIONS

Terminal Series No.	Bellmouth		Cut-Off Tab Max.		Conductor Brush	
	mm	(in)	mm	(in)	mm	(in)
50372-8*00	0.05-0.35	(.002-.014)	0.15	(.006)	0.00-0.50	(.000-.020)

Terminal Series No.	Bend Up	Bend Down	Twist	Roll	Punch Width mm	
	Degree	Degree	Degree	Degree	Conductor	Insulation
50372-8*00	4	3	3	4	1.20	1.40

The above conditions are guidelines to an optimum crimp.

CONDITIONS

After crimping, the conductor profile should measure the following.

Terminal Series	Wire Size		Crimp Height		Pull Force Min	
	Awg	(mm ²)	mm	(in)	N	(lbs)
50372-8*00	22	(0.35)	0.70-0.75	(.027-.029)	39.1	(8.8)
50372-8*00	24	(0.20)	0.62-0.67	(.024-.026)	29.3	(6.6)
50372-8*00	26	(0.12)	0.57-0.62	(.022-.024)	19.6	(4.4)

Pull Force measured with no influence from the insulation crimp

PARTS LIST

Item Number	Order Number	Eng Number	Description	Qty	Kit Part
1	634441204	634441204	Conductor Punch	1	Y
2	634451212	634451212	Conductor Anvil	1	Y
3	634461402	634461402	Insulation Punch	1	Y
4	634451405	634451405	Insulation Anvil	1	Y
5	634430003	634430003	Cut-Off Plunger	1	Y
6	634430012	634430012	Front Plunger Retainer	1	Y
7	11-24-1067	4996-4	Cut-Off Plunger Spring	1	
8	11-40-4039	8302-5	Front Plunger Striker	1	
9	634430021	634430021	Lower Tooling Key	1	
10	634436003	634436003	Rear Cover	1	
11	11-18-4083	60707-8	Front Cover	1	
12	634432403	634432403	Anvil Mount	1	
13	634434025	634434025	Wire Stop	1	
14	634430009	634430009	Scrap Chute	1	
15	638004900	638004900	FineAdjust Applicator	1	
70	638628070	638628070	Tool Kit (All "Y" Items)	0	

NOTES

1. We recommend an extra perishable tooling kit be maintained at your facility.
2. Verify tooling alignment by manually cycling the press and Applicator before crimping under power.
3. Slugs , Terminals, Dirt and Oil should be kept clear of work area.
4. This applicator should only be used in a press with a shut height of 135.8 mm (5.346"). Tooling damage could result at a lower setting.
5. **** CAUTION**** To prevent injury never operate this Applicator without the guarding supplied with the press or wire processing machine in place. Reference the press or wire processing manufacturer's instruction manual.
6. Wear safety glasses at all times.

ASSEMBLY DRAWING

The drawing below is a generic drawing representation. Some detail may not be shown. The FineAdjust applicator assembly and parts list can be found in the FineAdjust manual.

