



Chipsmall Limited consists of a professional team with an average of over 10 year of expertise in the distribution of electronic components. Based in Hongkong, we have already established firm and mutual-benefit business relationships with customers from,Europe,America and south Asia,supplying obsolete and hard-to-find components to meet their specific needs.

With the principle of “Quality Parts,Customers Priority,Honest Operation,and Considerate Service”,our business mainly focus on the distribution of electronic components. Line cards we deal with include Microchip,ALPS,ROHM,Xilinx,Pulse,ON,Everlight and Freescale. Main products comprise IC,Modules,Potentiometer,IC Socket,Relay,Connector.Our parts cover such applications as commercial,industrial, and automotives areas.

We are looking forward to setting up business relationship with you and hope to provide you with the best service and solution. Let us make a better world for our industry!



Contact us

Tel: +86-755-8981 8866 Fax: +86-755-8427 6832

Email & Skype: info@chipsmall.com Web: www.chipsmall.com

Address: A1208, Overseas Decoration Building, #122 Zhenhua RD., Futian, Shenzhen, China





**FineAdjust
Applicator**

**Application Tooling
Specification Sheet**

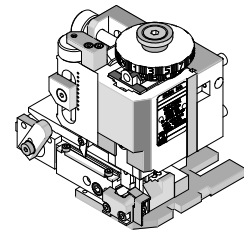

Order No. 63901-4700

FEATURES

- Directly adapts to most automatic wire processing machines
- Quick punch removal with the push of a button for fast and easy tooling change
- Applicator designed to industry standard mounting and shut height 135.80mm (5.346")
- Quick set-up time; plus the crimp height, track and feed adjustments can be set without removing the applicator from the press
- Fine adjustment allows users to achieve target with little effort by adjusting in increments of .015mm (.0006") for conductor crimp height and .063mm (.0025") for insulation height
- Independent adjustment rings allow users to quickly adjust the conductor or insulation crimp height without affecting each other

SCOPE

Products: Solar Shingle Receptacle Crimp Terminal, 14 AWG.

Terminal Series No.	Terminal Order No.	Wire Size		Insulation Diameter				Strip Length ✕	
				IPC/WHMA-A620		Terminal			
		AWG	mm ²	mm	In.	mm	In.	mm	In.
46942	46942-0001	14 (7/24)	2.27	N/A	N/A	N/A	N/A	19.75-20.25	0.78-0.80
171217	171217-0003	14 (7/24)	2.27	N/A	N/A	N/A	N/A	19.75-20.25	0.78-0.80

DEFINITION OF TERMS

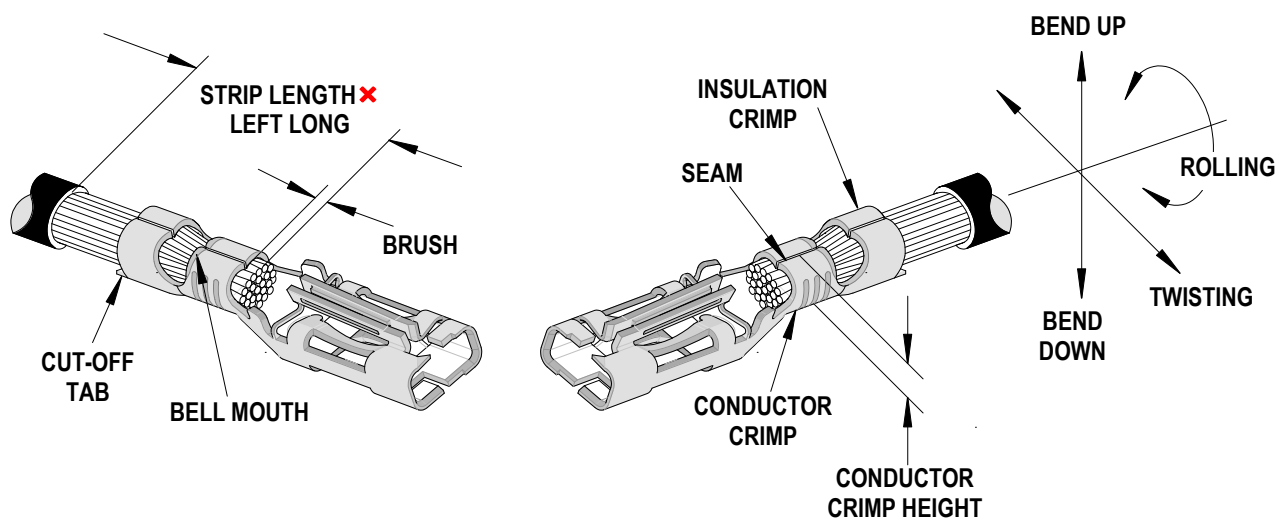

CRIMP SPECIFICATION

Terminal Series No.	Bell mouth (Entry Side)		Cut-off Tab Maximum		Conductor Brush	
	mm	In.	mm	In.	mm	In.
46942	0.30-0.45	.012-.018	0.35	.014	.76	.030
171217						

Terminal Series No.	Bend up	Bend down	Twist	Roll	Punch Width mm (Ref)				Seam Seam shall not be open and no wire allowed out of the crimping area
	Degree		Degree		Conductor		Insulation		
	mm	In	mm	In	mm	In			
46942	3	3	4	8	2.30	.091	3.90	.154	
171217	3	3	4	8	2.30	.091	3.90	.154	

After crimping, the conductor profile should measure the following.

Terminal Series No.	Wire Size		Conductor				✗Insulation				Pull Force Minimum	
			Crimp Height		Crimp Width (Ref)		Crimp Height Maximum		Crimp Width Maximum (Ref.)			
	AWG	mm ²	mm	In.	mm	In.	mm	In.	mm	In.	N	Lb.
46942	14	2.27	1.75-1.86	.069-.073	2.30	.091	2.7	.100	3.90	.154	222.4	50.0
171217	14	2.27	1.75-1.86	.069-.073	2.30	.091	2.7	.100	3.90	.154	222.4	50.0

✗Insulation Crimp Special Notes:

1. The tooling for this applicator is intentionally designed to assist in reducing the insulation/conductor step that is on the bottom of the terminal.
2. The wire is intentionally stripped long, so that the copper stranding is completely exposed in the insulation grips.
3. After crimping, the insulation grips shall be formed so the sides of the insulation grips do not touch the wire. The insulation grips may gently rest on top of the wire strands. The insulation grips are to be formed to slip into the connector housing, but will provide no wire strain relief.

■ Tool Qualification Notes:

1. Pull Force should be measured with no influence from the insulation crimp.
2. The above specifications are guidelines to an optimum crimp.

PARTS LIST

FineAdjust Applicator 63901-4700				
Item	Order No	Engineering No.	Description	Quantity
Perishable Tooling				
	63901-4770	63901-4770	Tool Kit (All "Y" Items)	REF
1	63444-2313	63444-2313	Conductor Punch	1 Y
2	63445-2336	63445-2336	Conductor Anvil	1 Y
3	63446-3937	63446-3937	Insulation Punch	1 Y
4	63445-3949	63445-3949	Insulation Anvil	1 Y
5	63443-0035	63443-0035	Front Cut-Off Plunger	1 Y
6	63443-0036	63443-0036	Front Plunger Retainer	1 Y
Other Components				
7	11-18-4083	60707-8	Feed Guide	1
8	63443-0009	63443-0009	Front Scrap Chute	1
9	63443-0024	63443-0024	Key	1
10	63443-0090	63443-0090	Wire Stop	1
11	63443-1717	63443-1717	18.70mm Height Spacer	1
12	63443-2202	63443-2202	2.00mm Coarse Spacer	1
13	63443-2216	63443-2216	16.00mm Coarse Spacer	1
14	63443-3160	63443-3160	Front Plunger Striker	1
15	63443-6121	63443-6121	Rear Cover	1
16	63700-0539	63700-0539	Cut-Off Plunger Spring	1
Frame				
17	63800-4901	63800-4901	Top	1
18	63801-3281	63801-3281	Base	1
19	63801-4650	63801-4650	Track	1
Hardware				
20	N/A	N/A	M3 by 6 Long SHCS	2**
21	N/A	N/A	M3 by 6 Long FHCS	1**
22	N/A	N/A	M4 by 6 Long SHCS	2**
23	N/A	N/A	M4 by 12 Long BHCS	2**
24	N/A	N/A	M4 by 50 Long SHCS	2**
25	N/A	N/A	M5 by 12 Lg SHCS	1**
26	N/A	N/A	#10-32 by 3/8" Long Flat Point SSS	1**
27	N/A	N/A	#10-32 Hex Jam Nut	1**
** Available from an industrial supply company such as MSC (1-800-645-7270).				

Assembly Drawing

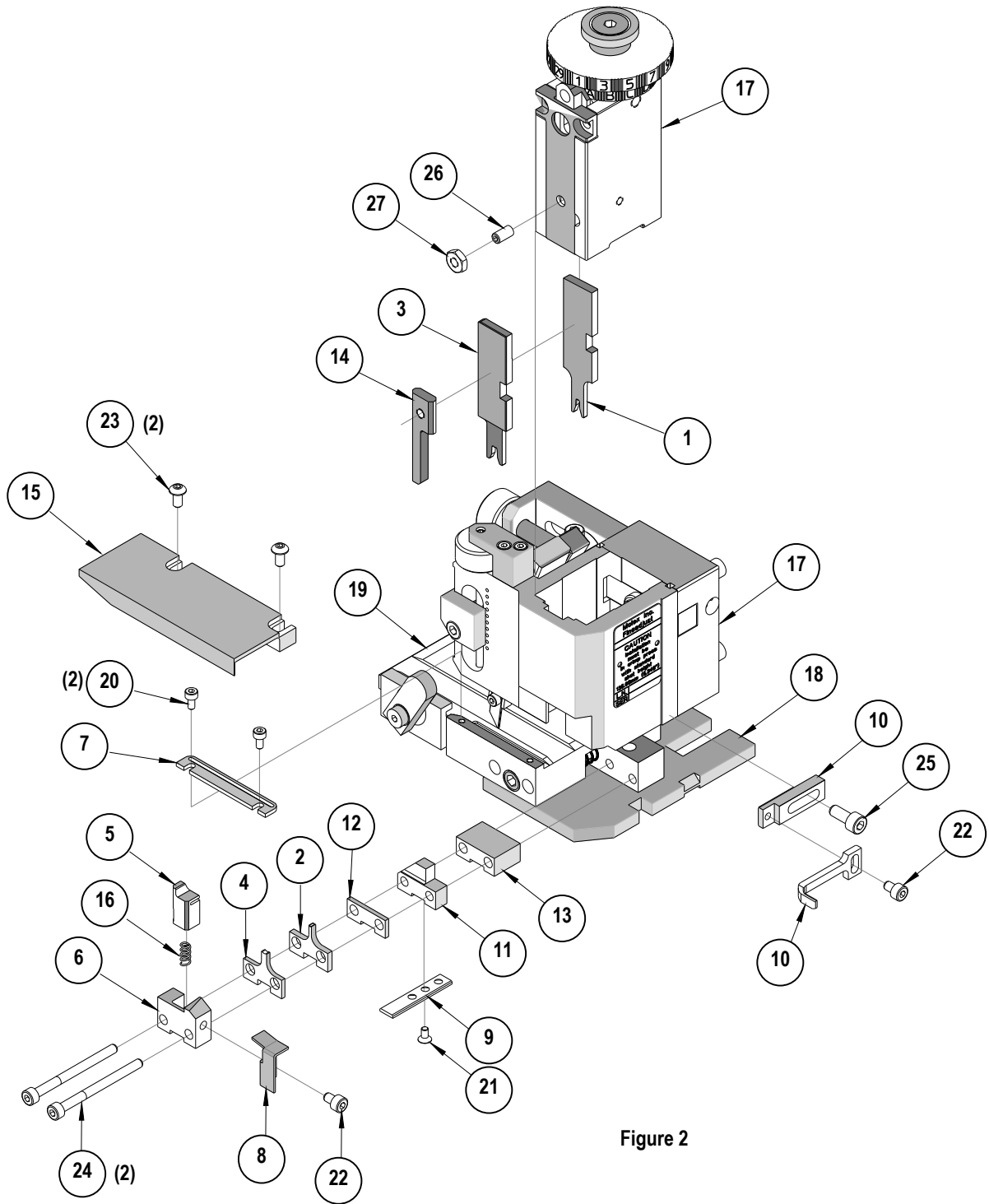

Figure 2

NOTES

1. Molex recommends an extra perishable tooling kit be maintained at your facility.
2. Verify tooling alignment by manually cycling the press and Applicator before crimping under power. Check that all screws are tight.
3. Slugs, Terminals, Dirt and Oil should be kept clear of work area.
4. Wear safety glasses at all times.
5. For recommended maintenance refer to the FineAdjust Manual.

CAUTION: This applicator should only be used in a press with a shut height of 135.8mm (5.346"). Tooling damage could result at a lower setting.

CAUTION: To prevent injury never operate this Applicator without the guards supplied with the press or wire-processing machine in place. Reference the press or wire processing manufacturer's instruction manual.

CAUTION: Molex crimp specifications are valid only when used with Molex terminals, applicators and tooling.

<http://www.molex.com>