



Chipsmall Limited consists of a professional team with an average of over 10 year of expertise in the distribution of electronic components. Based in Hongkong, we have already established firm and mutual-benefit business relationships with customers from,Europe,America and south Asia,supplying obsolete and hard-to-find components to meet their specific needs.

With the principle of “Quality Parts,Customers Priority,Honest Operation,and Considerate Service”,our business mainly focus on the distribution of electronic components. Line cards we deal with include Microchip,ALPS,ROHM,Xilinx,Pulse,ON,Everlight and Freescale. Main products comprise IC,Modules,Potentiometer,IC Socket,Relay,Connector.Our parts cover such applications as commercial,industrial, and automotives areas.

We are looking forward to setting up business relationship with you and hope to provide you with the best service and solution. Let us make a better world for our industry!



## Contact us

Tel: +86-755-8981 8866 Fax: +86-755-8427 6832

Email & Skype: info@chipsmall.com Web: www.chipsmall.com

Address: A1208, Overseas Decoration Building, #122 Zhenhua RD., Futian, Shenzhen, China





# FineAdjust Applicator Specification Sheet Order No. 63901-5300

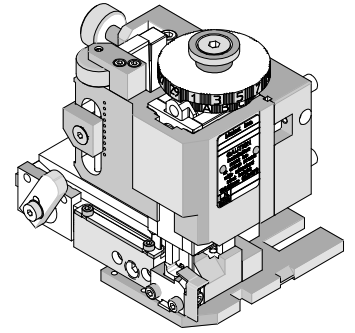

## FEATURES

- Quick punch removal with the push of a button for fast and easy tooling change
- Applicator designed to industry standard mounting and shut height 135.80mm (5.346")
- Quick set-up time; plus the crimp height, track and feed adjustments can be set without removing the applicator from the press
- Fine adjustment allows users to achieve target with little effort by adjusting in increments of .015mm (.0006") for conductor crimp height and .063mm (.0025") for insulation height
- Independent adjustment rings allow users to quickly adjust the conductor or insulation crimp height without affecting each other
- Directly adapts to most automatic wire processing machines

## SCOPE

Products: Mini-Fit Jr.™, Mini-Fit HCS™, and Mini-Fit Plus HCS™ Crimp Terminal 16 AWG with smaller insulation OD's.

Terminal Series No.	Terminal Order No.		Wire Size		Insulation Diameter				Strip Length	
					IPC/WHMA-A620 ♦		Terminal ♦ ♦			
					AWG	mm <sup>2</sup>	mm	In.		
5556	39-00-0077	39-00-0173	16	1.31	1.80-2.20	.071-.087	1.80-3.10	.071-.122	3.00-3.50	.118-.138
	39-00-0079	39-00-0179								
	39-00-0089	39-00-0185								
	39-00-0093	39-00-0198								
	39-00-0112	39-00-0204								
	39-00-0118	39-00-0211								
	39-00-0141	39-00-0217								
	39-00-0157	39-00-0447								
	39-00-0167									
5558	39-00-0081	39-00-0147	16	1.31	1.80-2.20	.071-.087	1.80-3.10	.071-.122	3.00-3.50	.118-.138
	39-00-0083	39-00-0223								
	39-00-0095	39-00-0449								
	39-00-0099	40-01-0855								
	39-00-0124	98-00-0176								
	39-00-0130									
44476	44476-3111	44476-3211	16	1.31	1.80-2.20	.071-.087	1.80-3.10	.071-.122	3.00-3.50	.118-.138
44478	44478-3111	44478-3211	16	1.31	1.80-2.20	.071-.087	1.80-3.10	.071-.122	3.00-3.50	.118-.138
44485	44485-3211	44485-3411	16	1.31	1.80-2.20	.071-.087	1.80-3.10	.071-.122	3.00-3.50	.118-.138
	44485-3311									
45750	45750-3111	45750-3211	16	1.31	1.80-2.20	.071-.087	1.80-3.15	.071-.124	3.00-3.50	.118-.138
46012	46012-3111	46012-3211	16	1.31	1.80-2.20	.071-.087	1.80-3.10	.071-.122	3.00-3.50	.118-.138
	46012-3141	46012-3241								
46018	46018-3541		16	1.31	1.80-2.20	.071-.087	1.80-3.10	.071-.122	3.00-3.50	.118-.138
46083	46083-3111	46083-3211	16	1.31	1.80-2.20	.071-.087	1.80-3.10	.071-.122	3.00-3.50	.118-.138
	46083-3121	46083-3221								
46098	46098-3541		16	1.31	1.80-2.20	.071-.087	1.80-3.10	.071-.122	3.00-3.50	.118-.138

Terminal Series No.	Terminal Order No.		Wire Size		Insulation Diameter				Strip Length	
					IPC/WHMA-A620 ♦		Terminal ♦♦			
			AWG	mm <sup>2</sup>	mm	In.	mm	In.	mm	In.
46134	46134-3111	46134-3121	16	1.31	1.80-2.20	.071-.087	1.80-3.10	.071-.122	3.00-3.50	.118-.138
	46134-3211	46134-3221								

♦ To achieve optimum IPC-A620 insulation crimps, use this insulation OD range.  
 ♦♦ Overall insulation OD specification for terminal.  
 Applicator 63900-2800 should be used for insulation O.D. 2.60-3.15mm (example UL1015).  
 Applicator 63900-3000 should be used for insulation O.D. 2.20-2.45mm (example UL1007).

### DEFINITION OF TERMS

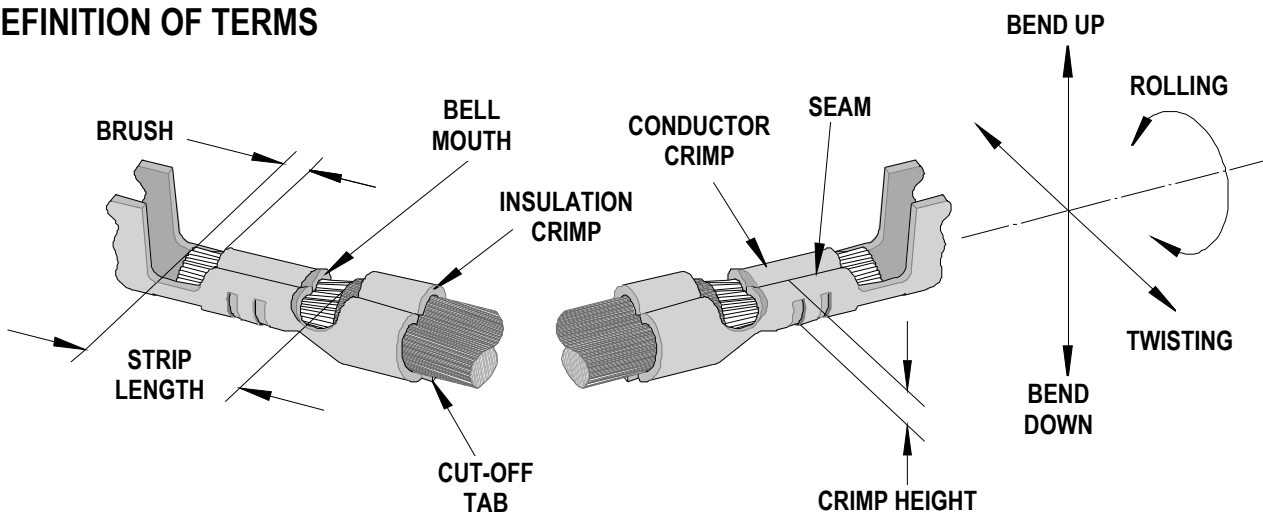

The above terminal drawing is a generic terminal representation. It is not an image of a terminal listed in the scope.

### CRIMP SPECIFICATION

Terminal Series No.	Bell mouth		Cut-off Tab Maximum		Conductor Brush	
	mm	In.	mm	In.	mm	In.
5556	0.20-0.50	.008-.020	0.30	.012	0.00-1.00	.000-.039
5558	0.20-0.50	.008-.020	0.30	.012	0.00-1.00	.000-.039
44476	0.20-0.50	.008-.020	0.30	.012	0.00-1.00	.000-.039
44478	0.20-0.50	.008-.020	0.30	.012	0.00-1.00	.000-.039
44485	0.20-0.50	.008-.020	0.30	.012	0.00-1.00	.000-.039
45750	0.20-0.50	.008-.020	0.30	.012	0.00-1.00	.000-.039
46012	0.20-0.50	.008-.020	0.30	.012	0.00-1.00	.000-.039
46018	0.20-0.50	.008-.020	0.30	.012	0.00-1.00	.000-.039
46083	0.20-0.50	.008-.020	0.30	.012	0.00-1.00	.000-.039
46098	0.20-0.50	.008-.020	0.30	.012	0.00-1.00	.000-.039
46134	0.20-0.50	.008-.020	0.30	.012	0.00-1.00	.000-.039

Terminal Series No.	Bend up	Bend down	Twist	Roll	Punch Width (Ref)			
					Conductor		Insulation	
	Degree		Degree		mm	In.	mm	In.
5556	5	2	5	15	1.90	.075	2.20	.087
5558	5	2	5	15	1.90	.075	2.20	.087
44476	5	2	5	15	1.90	.075	2.20	.087
44478	5	2	5	15	1.90	.075	2.20	.087
44485	5	2	5	15	1.90	.075	2.20	.087
45750	5	2	5	15	1.90	.075	2.20	.087
46012	5	2	5	15	1.90	.075	2.20	.087
46018	5	2	5	15	1.90	.075	2.20	.087
46083	5	2	5	15	1.90	.075	2.20	.087
46098	5	2	5	15	1.90	.075	2.20	.087
46134	5	2	5	15	1.90	.075	2.20	.087

**Seam**

Seam shall not be open  
And no wire allowed out  
of the crimping area

After crimping, the crimp profiles should measure the following:

Terminal Series No.	Wire Size		Conductor				Pull Force Minimum	
			Crimp Height		Crimp Width (Ref)			
	AWG	mm <sup>2</sup>	mm	In.	mm	In.	N	Lb.
5556	16	1.31	1.14-1.24	.045-.049	1.97	.078	68.4	15.4
5558	16	1.31	1.14-1.24	.045-.049	1.97	.078	68.4	15.4
44476	16	1.31	1.14-1.24	.045-.049	1.97	.078	68.4	15.4
44478	16	1.31	1.14-1.24	.045-.049	1.97	.078	68.4	15.4
44485	16	1.31	1.14-1.24	.045-.049	1.97	.078	68.4	15.4
45750	16	1.31	1.14-1.24	.045-.049	1.97	.078	68.4	15.4
46012	16	1.31	1.14-1.24	.045-.049	1.97	.078	68.4	15.4
46018	16	1.31	1.14-1.24	.045-.049	1.97	.078	68.4	15.4
46083	16	1.31	1.14-1.24	.045-.049	1.97	.078	68.4	15.4
46098	16	1.31	1.14-1.24	.045-.049	1.97	.078	68.4	15.4
46134	16	1.31	1.14-1.24	.045-.049	1.97	.078	68.4	15.4

**\* Tool Qualification Notes:**

1. Pull Force should be measured with no influence from the insulation crimp.
2. The above specifications are guidelines to an optimum crimp.

**PARTS LIST**

<b>FineAdjust Applicator 63901-5300</b>				
<b>Item</b>	<b>Order No</b>	<b>Engineering No.</b>	<b>Description</b>	<b>Quantity</b>
<b>Perishable Tooling</b>				
	63901-5370	63901-5370	Tool Kit (All "Y" Items)	REF
1	63444-1909	63444-1909	Conductor Punch	1 Y
2	63445-1943	63445-1943	Conductor Anvil	1 Y
3	63446-2241	63446-2241	Insulation Punch	1 Y
4	63445-2265	63445-2265	Insulation Anvil	1 Y
5	63443-0002	63443-0002	Cut-Off Plunger Front	1 Y
6	63443-0012	63443-0012	Plunger Retainer Front	1 Y
<b>Other Components</b>				
7	11-18-4083	60707-8	Feed Guide	1
8	11-24-1067	4996-4	Cut-Off Plunger Spring	1
9	63443-0009	63443-0009	Front Scrap Chute	1
10	63443-0024	63443-0024	Key	1
11	63443-0090	63443-0090	Wire Stop	1
12	63443-1717	63443-1717	18.70mm Height Spacer	1
13	63443-2216	63443-2216	16.00mm Coarse Spacer	1
14	63443-2302	63443-2302	3.10mm Fine Spacer	1
15	63443-2802	63443-2802	Plunger Striker	1
16	63443-2908	63443-2908	Wire Hold Down Plunger	1
17	63443-6111	63443-6111	Rear Cover	1
18	63600-1057	63600-1057	Compression Spring	1
<b>Frame</b>				
19	63800-4901	63800-4901	Top	1
20	63801-3281	63801-3281	Base	1
21	63801-4650	63801-4650	Track	1
<b>Hardware</b>				
22	N/A	N/A	M3 by 6 Long SHCS	2**
23	N/A	N/A	M3 by 6 Long FHCS	1**
24	N/A	N/A	M4 by 6 Long SHCS	2**
25	N/A	N/A	M4 by 12 Long BHCS	2**
26	N/A	N/A	M4 by 50 Long SHCS	2**
27	N/A	N/A	M5 by 12 Long SHCS	1**
28	N/A	N/A	#10-32 by 3/8" Long Flat Point SSS	1**
29	N/A	N/A	#10-32 Hex Jam Nut	1**
** Available from an industrial supply company such as MSC (1-800-645-7270).				

# Assembly Drawing

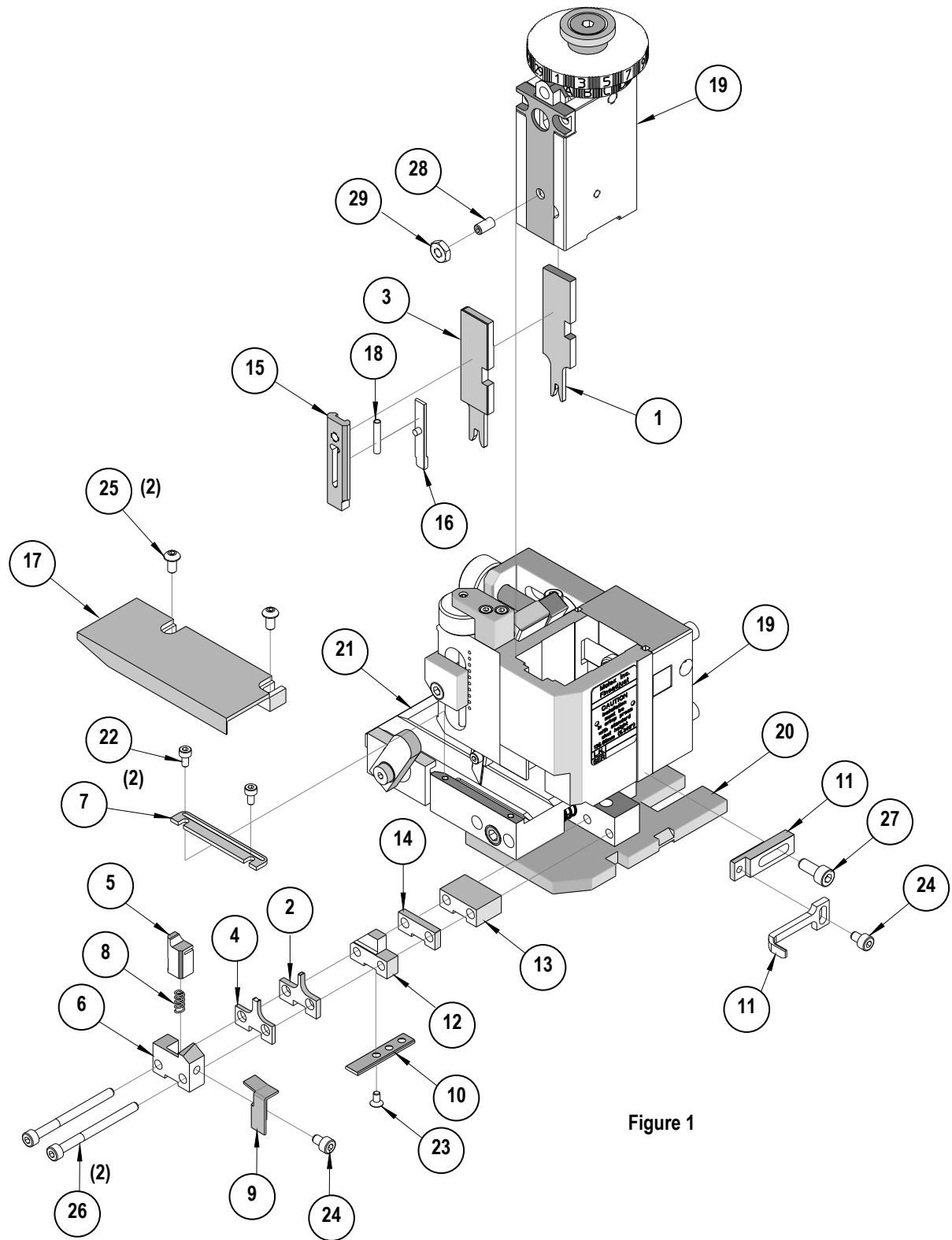

Figure 1

## NOTES

1. Molex recommends an extra perishable tooling kit be maintained at your facility.
2. Verify tooling alignment by manually cycling the press and Applicator before crimping under power. Check that all screws are tight.
3. Slugs, Terminals, Dirt and Oil should be kept clear of work area.
4. Wear safety glasses at all times.
5. For recommended maintenance refer to the FineAdjust Manual.

**CAUTION:** This applicator should only be used in a press with a shut height of 135.80 mm (5.346"). Tooling damage could result at a lower setting.

**CAUTION:** To prevent injury never operate this Applicator without the guards supplied with the press or wire-processing machine in place. Reference the press or wire processing manufacturer's instruction manual.

**CAUTION:** Molex crimp specifications are valid only when used with Molex terminals, applicators and tooling.

**Americas Headquarters**  
Lisle, Illinois 60532 U.S.A.  
1-800-78MOLEX  
amerinfo@molex.com

**Far East North Headquarters**  
Yamato, Kanagawa, Japan  
81-462-65-2324  
feninfo@molex.com

**Far East South Headquarters**  
Jurong, Singapore  
65-6-268-6868  
fesinfo@molex.com

**European Headquarters**  
Munich, Germany  
49-89-413092-0  
eurinfo@molex.com

**Corporate Headquarters**  
2222 Wellington Ct.  
Lisle, IL 60532 U.S.A.  
630-969-4550  
Fax: 630-969-1352

Visit our Web site at <http://www.molex.com>