



Chipsmall Limited consists of a professional team with an average of over 10 year of expertise in the distribution of electronic components. Based in Hongkong, we have already established firm and mutual-benefit business relationships with customers from,Europe,America and south Asia,supplying obsolete and hard-to-find components to meet their specific needs.

With the principle of “Quality Parts,Customers Priority,Honest Operation,and Considerate Service”,our business mainly focus on the distribution of electronic components. Line cards we deal with include Microchip,ALPS,ROHM,Xilinx,Pulse,ON,Everlight and Freescale. Main products comprise IC,Modules,Potentiometer,IC Socket,Relay,Connector.Our parts cover such applications as commercial,industrial, and automotives areas.

We are looking forward to setting up business relationship with you and hope to provide you with the best service and solution. Let us make a better world for our industry!



Contact us

Tel: +86-755-8981 8866 Fax: +86-755-8427 6832

Email & Skype: info@chipsmall.com Web: www.chipsmall.com

Address: A1208, Overseas Decoration Building, #122 Zhenhua RD., Futian, Shenzhen, China





**FineAdjust
Applicator**

**Application Tooling
Specification Sheet**

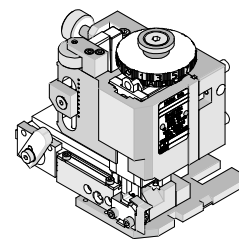

Order No. 63903-0200

FEATURES

- Directly adapts to most automatic wire processing machines
- Quick punch removal with the push of a button for fast and easy tooling change
- Applicator designed to industry standard mounting and shut height 135.80mm (5.346")
- Quick set-up time; plus the crimp height, track and feed adjustments can be set without removing the applicator from the press
- Fine adjustment allows users to achieve target with little effort by adjusting in increments of .015mm (.0006") for conductor crimp height and .063mm (.0025") for insulation height
- Independent adjustment rings allow users to quickly adjust the conductor or insulation crimp height without affecting each other

SCOPE

Products: Male and Female Terminal Ditto Interconnects, 20-22 AWG.

Terminal Series No.	Terminal Order No.	Wire Size		Insulation Diameter				Strip Length	
				IPC/WHMA-A620 (1)		Terminal (2)			
		AWG	mm ²	mm	In.	mm	In.	mm	In.
36876	36876-0001	20-22	0.50-0.35	1.45-1.70	.057-.067	1.35-1.70	.053-.067	2.30-2.80	.091-.110

(1) To achieve optimum IPC-A620 insulation crimps, use this insulation OD range.
 (2) Overall insulation OD specification for terminal.

DEFINITION OF TERMS

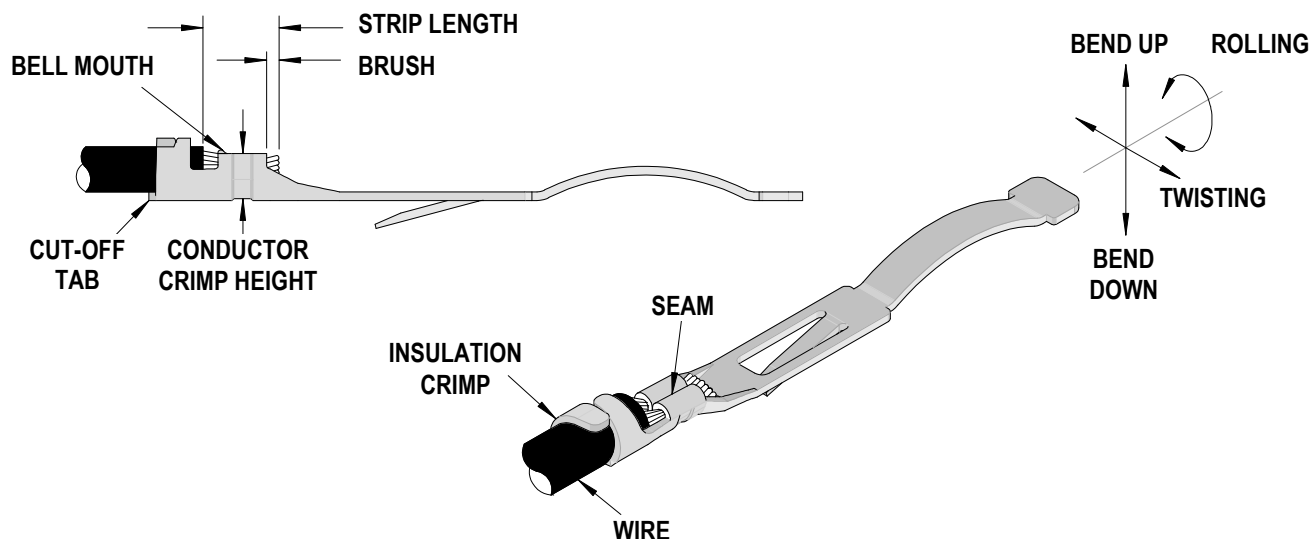

CRIMP SPECIFICATION

Terminal Series No.	Bell mouth		Cut-off Tab Maximum		Conductor Brush	
	mm	In.	mm	In.	mm	In.
36876	0.10-1.00	.004-.039	0.50	.020	0.20-1.00	.008-.039

Terminal Series No.	Bend up	Bend down	Twist	Roll	Punch Width mm (Ref)				Seam Seam shall not be open and no wire allowed out of the crimping area
	Degree		Degree		Conductor		Insulation		
					mm	In	mm	In	
36876	3	3	4	8	1.70	.067	1.90	.075	

After crimping, the conductor profile should measure the following.

Terminal Series No.	Wire Size		Conductor				Pull Force Minimum	
	AWG	mm ²	Crimp Height		Crimp Width (Ref)		N	Lb.
			mm	In.	mm	In.		
36876	20	0.50	1.10-1.20	.043-.047	1.75	.069	36.0	8.09
36876	22	0.35	1.00-1.10	.039-0.43	1.75	.069	36.0	8.09

Terminal Series No.	Wire Size		Insulation			
	AWG	mm ²	Crimp Height (Maximum)		Crimp Width (Ref.)	
			mm	In.	mm	In.
36876	20	0.50	2.10	.083	2.00	.079
36876	22	0.35	2.10	.083	2.00	.079

Tool Qualification Notes:

1. Pull Force should be measured with no influence from the insulation crimp.
2. The above specifications are guidelines to an optimum crimp.

PARTS LIST

FineAdjust Applicator 63903-0200				
Item	Order No	Engineering No.	Description	Quantity
Perishable Tooling				
	63903-0270	63903-0270	Tool Kit (All "Y" Items)	REF
1	63444-1709	63444-1709	Conductor Punch	1 Y
2	63455-1701	63455-1701	Conductor Anvil	1 Y
3	63454-1902	63454-1902	Insulation Punch	1 Y
4	63445-1918	63445-1918	Insulation Anvil	1 Y
5	63443-0005	63443-0005	Cut-Off Plunger Front	1 Y
6	63443-0012	63443-0012	Plunger Retainer Front	1 Y
Other Components				
7	11-17-0022	1739-21	Hold-Down Spring	1
8	11-18-4083	60707-8	Front Cover	1
9	11-24-1067	4996-4	Cut-off Plunger Spring	1
10	63443-0009	63443-0009	Scrap Chute Front	1
11	63443-0024	63443-0024	Lower Tooling Key	1
12	63443-0090	63443-0090	Wire Stop	1
13	63443-0093	63443-0093	Shank	1
14	63443-1718	63443-1718	Height Spacer (18.80mm)	1
15	63443-2201	63443-2201	Coarse Spacer (1.0mm)	1
16	63443-2215	63443-2215	Coarse Spacer (15.0mm)	1
17	63443-2306	63443-2306	Fine Spacer (3.30mm)	1
18	63443-2805	63443-2805	Plunger Striker Front	1
19	63443-2906	63443-2906	Wire Hold-Down Plunger	1
20	63443-6113	63443-6113	Rear Cover	1
21	63600-0021	63600-0021	Wire Hold-Down Spring	1
22	63890-0192	63890-0192	Terminal Hold-Down	1
Frame				
23	63800-4901	63800-4901	Top	1
24	63801-3281	63801-3281	Base	1
25	63801-4650	63801-4650	Track	1
Hardware				
26	N/A	N/A	M3 by 6 Long FHCS	1**
27	N/A	N/A	M3 by 6 Long SHCS	2**
28	N/A	N/A	M3 by 8 Long SHCS	1**
29	N/A	N/A	M4 by 6 Long SHCS	2**
30	N/A	N/A	M4 by 12 Long BHCS	2**
31	N/A	N/A	M4 by 50 Long SHCS	2**
32	N/A	N/A	M5 by 12 Long SHCS	1**
33	N/A	N/A	#10-32 by 3/8" Long Flat Point SSS	1**
34	N/A	N/A	#10-32 Hex Jam Nut	1**
** Available from an industrial supply company such as MSC (1-800-645-7270).				

Assembly Drawing

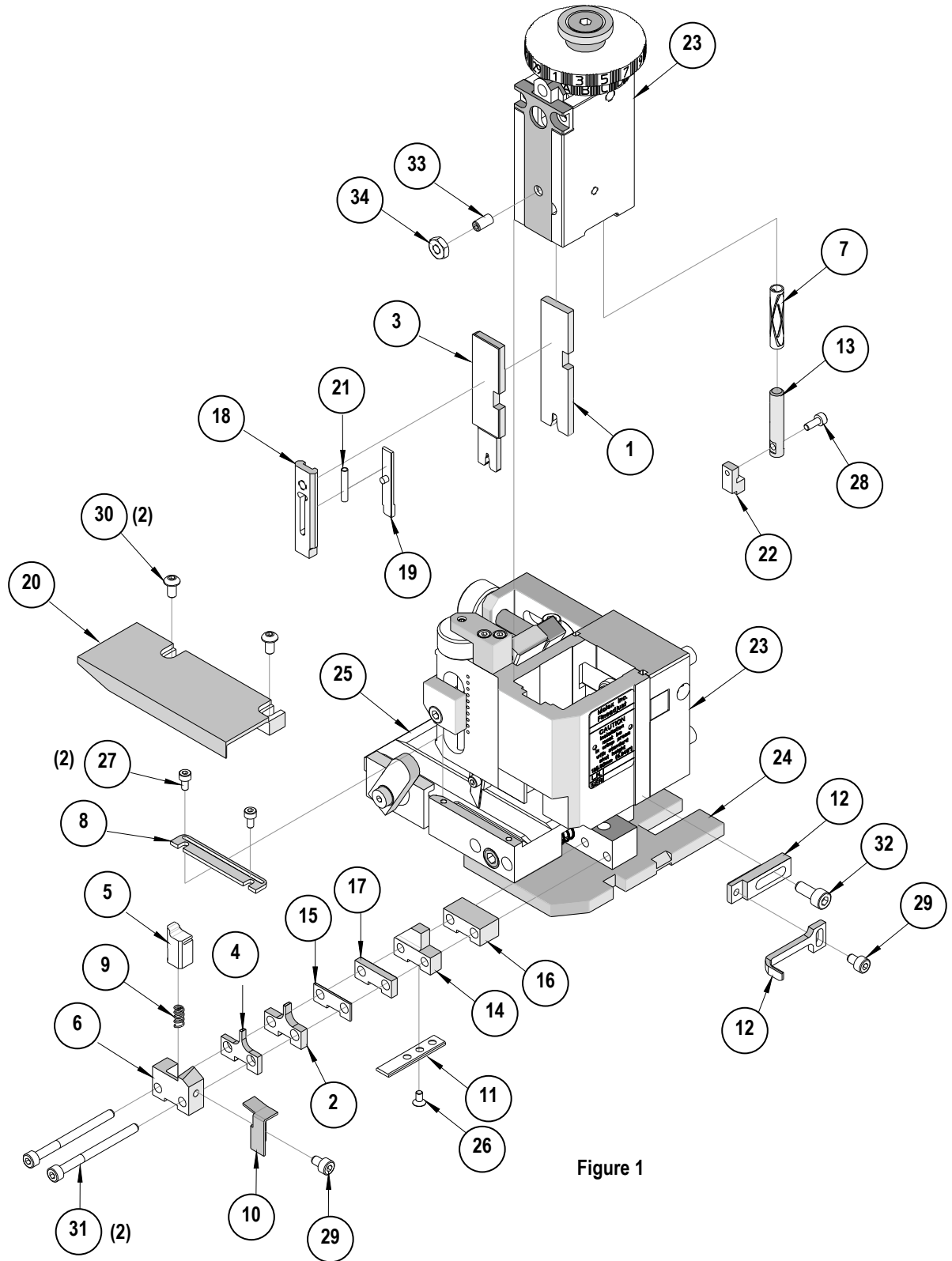

Figure 1

NOTES

1. Molex recommends an extra perishable tooling kit be maintained at your facility.
2. Verify tooling alignment by manually cycling the press and Applicator before crimping under power. Check that all screws are tight.
3. Slugs, Terminals, Dirt and Oil should be kept clear of work area.
4. Wear safety glasses at all times.
5. For recommended maintenance refer to the FineAdjust Manual.

CAUTION: This applicator should only be used in a press with a shut height of 135.8mm (5.346"). Tooling damage could result at a lower setting.

CAUTION: To prevent injury never operate this Applicator without the guards supplied with the press or wire-processing machine in place. Reference the press or wire processing manufacturer's instruction manual.

CAUTION: Molex crimp specifications are valid only when used with Molex terminals, applicators and tooling.

Visit our Web site at <http://www.molex.com>