



Chipsmall Limited consists of a professional team with an average of over 10 year of expertise in the distribution of electronic components. Based in Hongkong, we have already established firm and mutual-benefit business relationships with customers from,Europe,America and south Asia,supplying obsolete and hard-to-find components to meet their specific needs.

With the principle of “Quality Parts,Customers Priority,Honest Operation,and Considerate Service”,our business mainly focus on the distribution of electronic components. Line cards we deal with include Microchip,ALPS,ROHM,Xilinx,Pulse,ON,Everlight and Freescale. Main products comprise IC,Modules,Potentiometer,IC Socket,Relay,Connector.Our parts cover such applications as commercial,industrial, and automotives areas.

We are looking forward to setting up business relationship with you and hope to provide you with the best service and solution. Let us make a better world for our industry!



Contact us

Tel: +86-755-8981 8866 Fax: +86-755-8427 6832

Email & Skype: info@chipsmall.com Web: www.chipsmall.com

Address: A1208, Overseas Decoration Building, #122 Zhenhua RD., Futian, Shenzhen, China





**Hand Crimp Tool Operating Instruction
And Specifications Sheet
Order No. 64001-1400
Eng. No. RHT 2100
(Replaces 19285-0013 and
19285-0016 RHT 2150)**

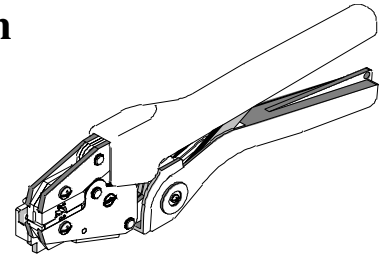

FEATURES

- A full cycle ratcheting hand tool ensures complete crimps
- Long handles for comfortable crimping with reduced crimping force
- A precision user-friendly terminal locator wire stop holds terminals in the proper crimping position
- Insulation crimp adjustment allows a precise insulation crimp. To meet or exceed the requirements of UL, CSA and Military Class II
- Single color-coded crimp pocket eliminates the possibility of using the wrong pocket

SCOPE

AviKrimp® and InsulKrimp® Terminals 14-16 AWG, (Rings, Spades, Hooks, Splices, Snap Spades, Flanged Spades and Wire Pin Terminals). Some Male Quick Disconnects and 3 to 4 Way Connectors. Also terminates ends of step down butt splices 14-16 AWG to 18-22 AWG. And Heavy Duty Terminals 16-20 AWG (Green color code).

Testing

Mechanical

The tensile test or pull test is a means of evaluating the mechanical properties of the crimped connections. The following charts show the UL and Government specifications (MIL-T-7928) for various wire sizes. The tensile strength is shown in pounds and indicates the minimum acceptable force to break or separate terminal from the conductor.

Wire Size (AWG)	*UL - 486 A	*UL - 486 C	**Military Class 2
22	8	8	15
20	13	10	19
18	20	10	38
16	30	15	50
14	50	25	70

*UL - 486 A - Terminals (Copper conductors only).

*UL - 486 C - Butt Splices, Parallel Splices, Closed End Connectors, and Wire Nuts.

**Military Class 2- Military Approved Terminals only as listed

The following is a partial list of the product part numbers and their specifications that this tool is designed to run. We will be adding to this list and an up to date copy is available on www.molex.com.

Wire Size: 14 - 16 AWG 2.00 - 1.30 mm ²					
Terminal No.	Terminal Eng No. (REF)	Wire Strip Length		Insul. Dia. Max.	
		In	mm	In	mm
19023-0012	MCT-2X	.312	7.94	.175	4.45
19025-0007	MCT-5	.312	7.94	.170	4.32
19025-0008	MCT-57	.312	7.94	.170	4.32
19034-0007	B-279X	.312	7.94	.175	4.45
19034-0009	B-289X	.312	7.94	.169	4.30
19035-0005	B-579	.312	7.94	.174	4.42
19035-0009	B-589	.312	7.94	.174	4.42
19036-0006	B-879	.312	7.94	.170	4.32
19036-0008	B-889	.312	7.94	.170	4.32

Wire Size: 14 - 16 AWG 2.00 - 1.30 mm ²					
Terminal No.	Terminal	Wire Strip Length		Insul. Dia. Max.	
		In	mm	In	mm
19070-0059	BB-218-38X	.234	5.95	.175	4.45
19070-0063	BB-218-56X	.234	5.95	.175	4.45
19070-0065	BB-223-02X	.234	5.95	.175	4.45
19070-0067	BB-223-04X	.234	5.95	.175	4.45
19070-0069	BB-223-06X	.234	5.95	.175	4.45
19070-0071	BB-223-08X	.234	5.95	.175	4.45
19070-0073	BB-225-10X	.234	5.95	.175	4.45
19070-0075	BB-225-14X	.234	5.95	.175	4.45
19070-0078	BB-225-56X	.234	5.95	.175	4.45

RHT2100 Hand Crimp Tool

Wire Size: 14 – 16 AWG 2.00 – 1.30 mm ²					
Terminal No.	Terminal Eng No. (REF)	Wire Strip Length		Insul. Dia. Max.	
		In	mm	In	mm
19070-0083	BB-237-06X	.234	5.95	.175	4.45
19070-0086	BB-237-08X	.234	5.95	.175	4.45
19070-0090	BB-237-10X	.234	5.95	.175	4.45
19070-0099	BB-239-08X	.234	5.95	.175	4.45
19070-0102	BB-239-10X	.234	5.95	.175	4.45
19073-0059	BB-818-38	.250	6.35	.170	4.32
19073-0061	BB-818-56	.250	6.35	.170	4.32
19073-0065	BB-823-04	.250	6.35	.170	4.32
19073-0067	BB-823-06	.250	6.35	.170	4.32
19073-0072	BB-823-08	.250	6.35	.170	4.32
19073-0074	BB-825-10	.250	6.35	.170	4.32
19073-0076	BB-825-14	.250	6.35	.170	4.32
19073-0079	BB-825-56	.250	6.35	.170	4.32
19073-0081	BB-837-04	.250	6.35	.170	4.32
19073-0083	BB-837-06	.250	6.35	.170	4.32
19073-0085	BB-837-08	.250	6.35	.170	4.32
19073-0087	BB-837-10	.250	6.35	.170	4.32
19073-0094	BB-839-08	.250	6.35	.170	4.32
19073-0097	BB-839-10	.250	6.35	.170	4.32
19080-0003	B-2006-MSX	.312	7.94	.175	4.45
19081-0003	B-5006-MS	.312	7.94		
19090-0044	BB-213-04X	.234	5.95	.175	4.45
19090-0046	BB-213-06X	.234	5.95	.175	4.45
19090-0048	BB-213-08X	.234	5.95	.175	4.45
190900071	BB-288-06X	.234	5.95	.175	4.45
19090-0075	BB-288-10X	.234	5.95	.175	4.45
19095-0135	BB-883-10	.250	6.35	.175	4.45
19095-0138	BB-886-08	.250	6.35	.170	4.32
19095-0140	BB-887-06	.250	6.35	.170	4.32
19095-0141	BB-887-08	.250	6.35	.170	4.32
19099-0025	BB-2707-05X	.234	5.95	.175	4.45
19099-0027	BB-2707-06X	.234	5.95	.175	4.45
19099-0032	BB-2716-08X	.234	5.95	.175	4.45
19115-0016	BB-8193-06	.250	6.35	.170	4.32
19115-0018	BB-8194-08	.250	6.35	.170	4.32
19115-0020	BB-8195-10	.250	6.35	.170	4.32
19115-0022	BB-8707-05	.250	6.35	.170	4.32
19115-0024	BB-8707-06	.250	6.35	.170	4.32
19115-0031	BB-8717-10	.250	6.35	.170	4.32
19115-0079	BB-8716-08	.250	6.35	.170	4.32
19121-0026	BB-216-06X	.234	5.95	.175	4.45
19121-0028	BB-216-08X	.234	5.95	.175	4.45
19121-0030	BB-216-10X	.234	5.95	.175	4.45
19121-0040	BB-283-10X	.234	5.95	.175	4.45
19127-0039	BB-816-06	.250	6.35	.170	4.32
19127-0042	BB-816-08	.250	6.35	.170	4.32
19127-0099	BB-816-10	.250	6.35	.170	4.32
19131-0007	BB-287-08X	.234	5.95	.175	4.45
19131-0014	BB-2781-10X	.234	5.95	.175	4.45
19131-0018	BB-2781-08X	.234	5.95	.175	4.45
19131-0020	BB-2781-06X	.234	5.95	.175	4.45
1913-10023	BB-2471-06X	.234	5.95	.175	4.45
19131-0025	BB-2471-04X	.234	5.95	.175	4.45
19139-0038	BB-8471-04	.250	6.35	.170	4.32
19139-0044	BB-8781-08	.250	6.35	.170	4.32
19139-0045	BB-8781-10	.250	6.35	.175	4.45

Wire Size: 14 – 16 AWG 2.00 – 1.30 mm ²					
Terminal No.	Terminal	Wire Strip Length		Insul. Dia. Max.	
		In	mm	In	mm
19144-0013	BB-207-04X	.312	7.94	.174	4.42
19144-0015	BB-207-06X	.234	5.95	.175	4.45
19144-0018	BB-224-06X	.234	5.95	.175	4.45
19144-0020	BB-224-08X	.234	5.95	.170	4.45
19154-0015	B-231X	.234	5.95	.175	4.45
19154-0023	BS-V-331X	.281	7.14	.179	4.57
19179-0008	BB-219-06X	.234	5.95	.175	4.45
19179-0010	BB-219-08X	.234	5.95	.175	4.45
19179-0012	BB-219-10X	.234	5.95	.175	4.45
19183-0009	BB-819-08	.250	6.35	.170	4.32
19183-0011	BB-819-10	.250	6.35	.170	4.32
19198-0012	BB-807-06	.234	5.95	.175	4.45
19198-0016	BB-824-06	.250	6.35	.170	4.32
19198-0019	BB-824-08	.250	6.35	.170	4.32
19198-0025	BB-827-10	.250	6.35	.170	4.32
19204-0013	B-2XCX	.312	7.94	.175	4.45
19204-0014	B-2YCX	.312	7.94	.175	4.45
19204-0017	B-5XC	.312	7.94	.174	4.42
19204-0018	B-5YC	.312	7.94	.174	4.42
19206-0004	B-204X	.281	7.14	.175	4.45
19206-0005	BS-V-304X	.281	7.14	.175	4.45
19212-0005	WP-2614X	.250	6.35	.170	4.32
19213-0011	WP-8614	.187	4.76	.175	4.45

STEP DOWN BUTT SPLICE					
Wire Size: 14 – 16 AWG 2.00 – 1.30 mm ² to 18-22 AWG .080-0.35 mm ²					
Terminal No.	Terminal Eng No. (REF)	Wire Strip Length		Insul. Dia. Max.	
		In	mm	In	mm
19154-0022	BA-631X	.281	7.14	.175	4.45

MILITARY CLASS 2					
Wire Size: 14 – 16 AWG 2.00 – 1.30 mm ²					
Terminal No.	Terminal Eng No. (REF)	Wire Strip Length		Insul. Dia. Max.	
		In	mm	In	mm
19095-0074	BB-882-2	.250	6.35	.171	4.36
19095-0076	BB-883-2	.250	6.35	.171	4.36
19095-0133	BB-880-2	.250	6.35	.171	4.36
19095-0134	BB-881-2	.250	6.35	.171	4.36
19095-0136	BB-884-2	.250	6.35	.171	4.36
19095-0137	BB-885-2	.250	6.35	.171	4.36
19095-0139	BB-886-2	.250	6.35	.171	4.36

HEAVY DUTY					
Wire Size: 16 – 20 AWG 1.30 – 0.50 mm ²					
Terminal No.	Terminal Eng No. (REF)	Wire Strip Length		Insul. Dia. Max.	
		In	mm	In	mm
19054-0060	AB-225-10HD	.234	5.94	.170	4.32
19054-0061	AB-225-14HD	.234	5.94	.170	4.32
19054-0062	AB-225-56HD	.234	5.94	.170	4.32
19073-0051	AB-825-10HD	.234	5.94	.170	4.32
19073-0053	AB-825-14HD	.234	5.94	.170	4.32
19073-0055	AB-825-56HD	.234	5.94	.170	4.32

OPERATION

Open the tool by first closing the jaws sufficiently for the ratchet mechanism to release.

Crimping Terminals

Note: The tamper proof ratchet action will not release the tool until

1. Push up on the locator blade and position the terminal with the barrel facing up into the color-coded nest with front edge of the barrel against the locator (See Figure 1). Release the locator blade to hold the terminal in position.
2. Partially close the tool to hold the terminal in place (See Figure 2).
3. Insert the properly stripped wire into the terminal barrel (See Figure 2 and 3). The wires end should butt against the wire stop position of the locator. Cycle the tool.
4. Lift the locator blade or wire stop and remove the crimped terminal. Inspect for proper crimp location, and check for insulation closure. Locator is adjustable up and down to keep terminals straight after crimping.

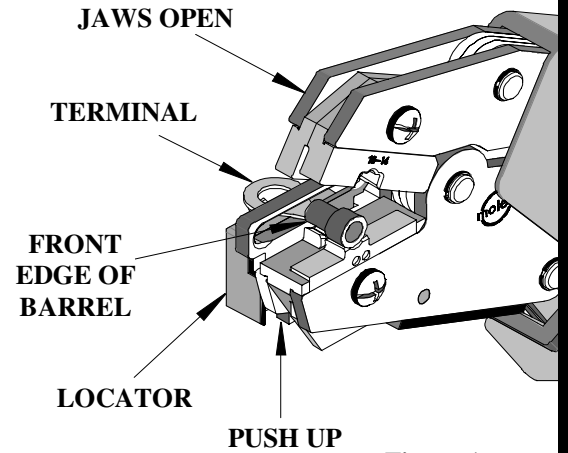

Figure 1

Note: Whenever crimping without the locator, make sure the seam of the terminal is oriented up or down in the tool if using unbrazed product, as this will provide higher pull force

5. If the insulation part of the crimp needs to be adjusted, first loosen the M4 screw on the bottom tool jaw, then insert a 3/32 hex wrench (supplied) into the bottom of the lower die (See Figure 5). A clockwise (CW) rotation decreases insulation crimp while a counter-clockwise (CCW) rotation increases insulation crimp. After adjusting retighten the M4 screw.

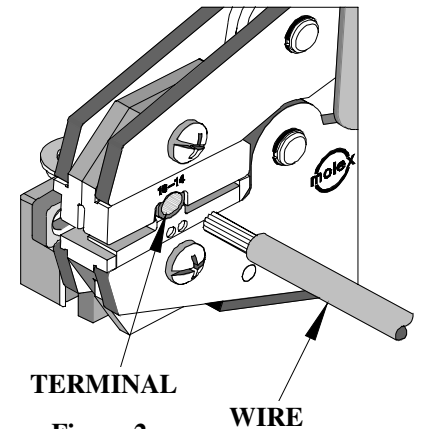

Figure 2

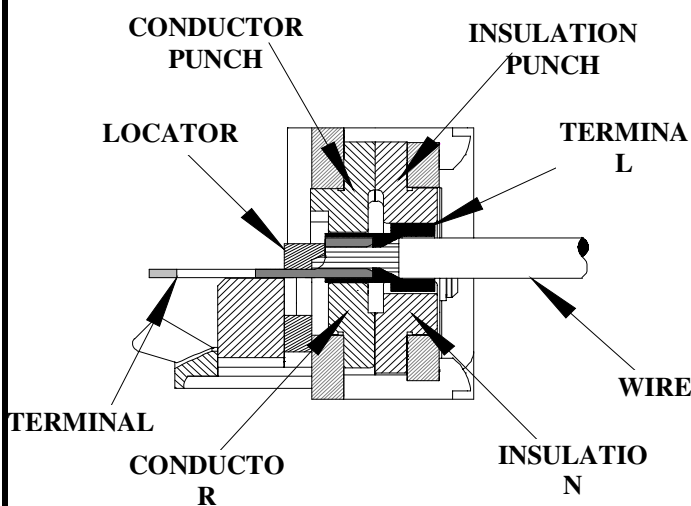

Figure 3

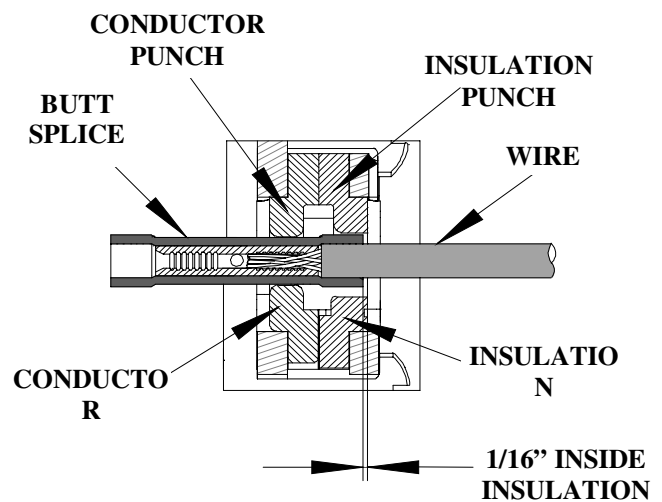

Figure 4

6. When crimping butt splices, or 3-way and 4-way terminals the locator must be removed. Splices must be visually aligned with the tooling 1/16" inside the insulation crimp (See Figure 4). The splice should be approximately centered inside the tooling nests (See Figure 4). Cycle the tool.

Maintenance

It is recommended that each operator of the tool be made aware of, and responsible for, the following maintenance steps:

1. Remove dust, moisture and other contaminants with a clean brush, or soft, lint-free cloth.
2. Do not use any abrasive materials that could damage the tool.
3. Make certain all pins, pivot points and bearing surfaces are protected with a thin coat of high quality machine oil. Do not oil excessively. The 64001-1400 (RHT-2100) was engineered for durability, but like any fine piece of equipment it needs cleaning and lubrication for a maximum service life of trouble-free crimping. A light oil, such as 30 weight automotive oil used at the oil points shown in Figure 5, every 5,000 crimps or 3 months will significantly enhance the tool life and ensure a stable calibration.
4. When tool is not in use, keep the handles closed to prevent objects from becoming lodged in the crimping dies, and store the tool in a clean, dry area.

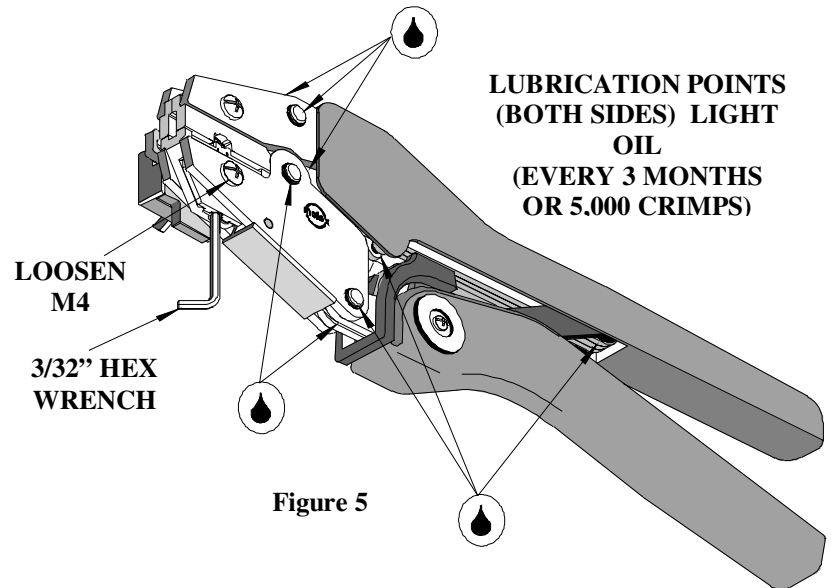

Figure 5

Miscrimps or Jams

Should this tool ever become stuck or jammed in a partially closed position, **Do Not force the handles open or closed.** The tool will open easily by lifting the ratchet release lever (See Fig.6).

How To Adjust Tool Preload (See Figure 6)

Over the life of the tool, it may be necessary to adjust tool handle preload force. Listed below are the steps required to adjust the crimping force of the hand tool to obtain proper crimp conditions:

1. Remove the screw and plastic cover washer. Note the setting wheel position.
2. Lift the setting wheel off the axle. Turn the eccentric axle with a screwdriver.
3. Turning the eccentric axle counter-clockwise (CCW) will increase handle force.
4. Replace the setting wheel to the axle, aligning the nearest notch in the setting wheel to the dowel pin.
5. Replace the plastic cover washer and screw.
6. Check the crimp specifications after tool handle preload force is adjusted.

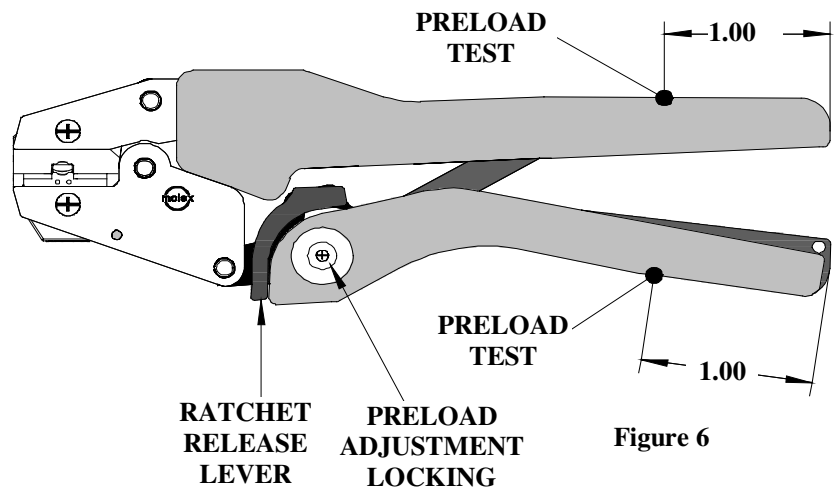
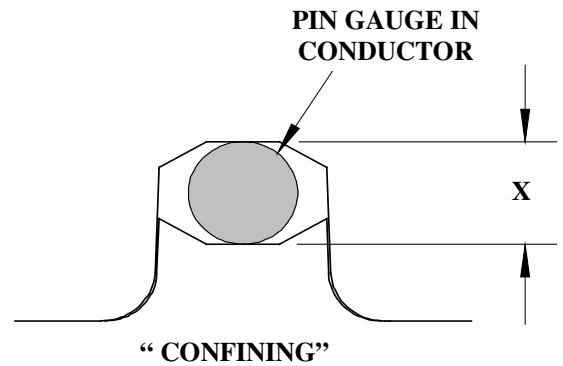

Figure 6

Tool Calibration

A Certificate of Calibration (see last page) was supplied with the tool. To recalibrate this tool, pin gauge measurements should be taken in each conductor nest and compared to this chart. The tool should be lubricated prior to recalibration to ensure consistent measurements. Handle preload is factory set to 25-45 LBS. See How to Adjust Tool Preload (see Figure 6) to recalibrate.



Nest Color Code	Wire Range		“X” Dimension Conductor Crimp			Crimp Inspection Marking
	AWG	mm ²	Mean	Go	No Go	
Blue	14 - 16	1.30 - 2.00	.122	.116	.128	o o
	16 - 20 HD	0.50 - 1.30	.122	.116	.128	o o
	18 - 22*	0.80 - 0.35	.122	.116	.128	o o

* 18 - 22 End of step down butt splice only.

Warranty

This tool is for electrical terminal crimping purposes only. This tool is made of the best quality materials. All vital components are long life tested. All tools are warranted to be free of manufacturing defects for a period of 30 days. Should such a defect occur, we will repair or exchange the tool free of charge. This repair or exchange will not be applicable to altered, misused or damaged tools. This tool is designed for hand use only. Any clamping, fixturing, or use of handle extensions voids this warranty.

Hand held crimping tools are intended for low volume, prototyping, or repair requirements only.

Caution: Repetitive use of this tool should be

PARTS LIST

Item	Order No	Description	Quantity
	64001-1400	Hand Crimp Tool	(Fig. 7)
1	64000-0076	Repair Kit (Springs, Pins and E-Rings)	1
2	63810-0000	Handle	1
3	64007-0375	Locator Assembly	1
4	64001-1470	Tooling Kit	1
Tooling Kit Only			
5	64001-1402	Conductor Punch	1
6	64001-1401	Conductor Anvil	1
7	64001-1404	Insulation Punch	1
8	64001-1403	Insulation Anvil	1
9	N/A	4 mm Dia. by 5.0 mm Lg. Roll Pins	2**
10	N/A	#10-32 by 5/16" Lg. Cup Pt. Set Screw	1**

** The following purchased parts are available from an Industrial supply company such as MSC (1-800-645-7270).

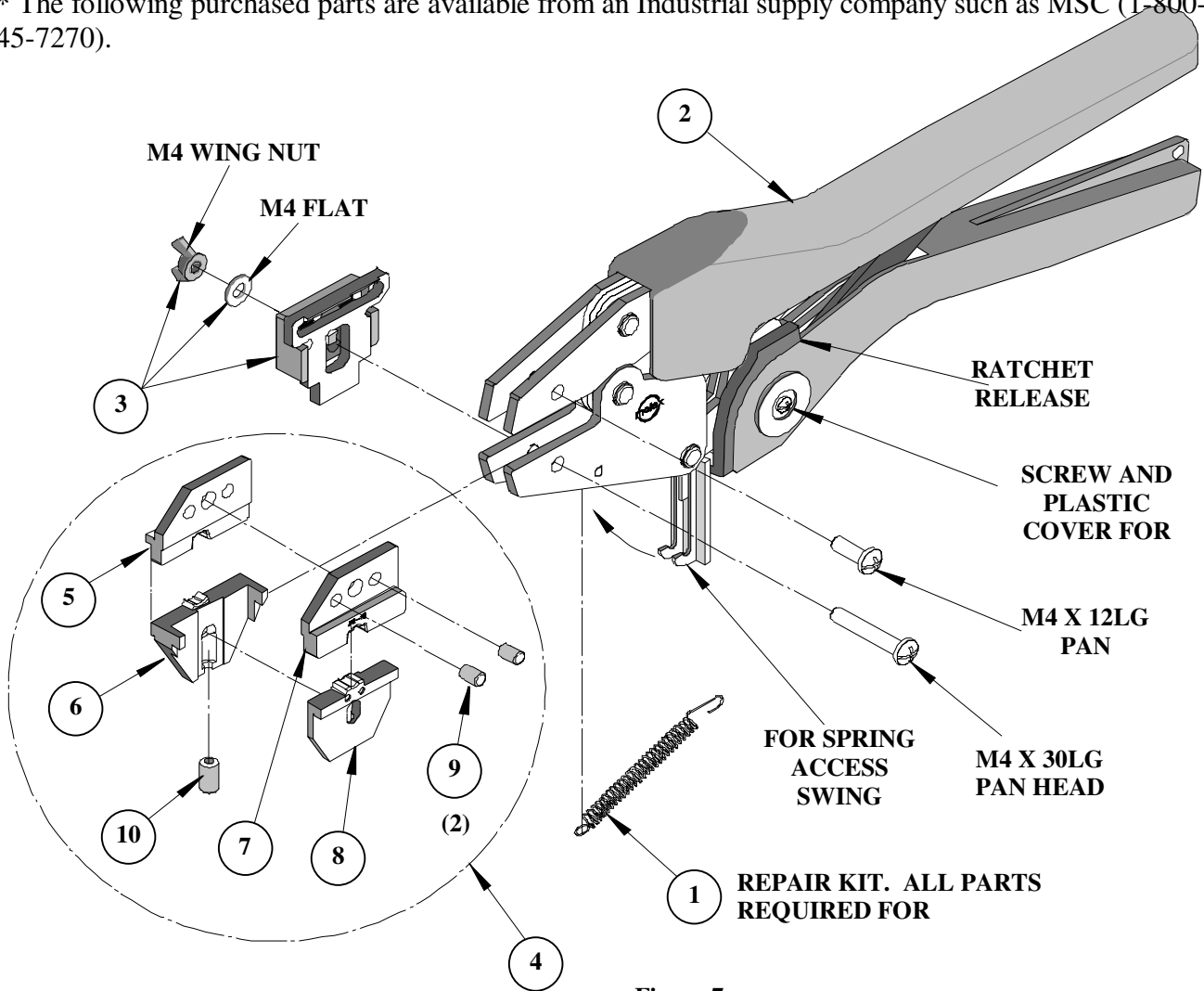
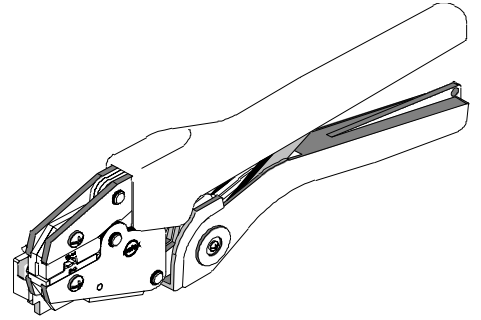

Figure 7



Certificate of Calibration

Tool Order Number _____

Tool Eng. Number _____

Tool Revision _____

Serial Number _____

Date of Manufacture _____

Handle Load Range at 1 inch from the Tips = _____

Actual = _____

Pin Gauge of Conductor Nest/Nests or Slug height if the nest is the "F" Crimp style.

Range Conductor Nest # 1 = _____ -- Actual = _____

Range Conductor Nest # 2 = _____ -- Actual = _____

Range Conductor Nest # 3 = _____ -- Actual = _____

Technician _____

Date of Calibration _____

Calibration should be done every 5,000 cycles or 3 months.
Tools should be lubricated during this operation.

Molex Application Tooling Group

1150 E. Diehl Road
Naperville, IL 60563
Te: 1(630) 969-4550
Fax: (630) 505-0049