



Chipsmall Limited consists of a professional team with an average of over 10 year of expertise in the distribution of electronic components. Based in Hongkong, we have already established firm and mutual-benefit business relationships with customers from,Europe,America and south Asia,supplying obsolete and hard-to-find components to meet their specific needs.

With the principle of “Quality Parts,Customers Priority,Honest Operation,and Considerate Service”,our business mainly focus on the distribution of electronic components. Line cards we deal with include Microchip,ALPS,ROHM,Xilinx,Pulse,ON,Everlight and Freescale. Main products comprise IC,Modules,Potentiometer,IC Socket,Relay,Connector.Our parts cover such applications as commercial,industrial, and automotives areas.

We are looking forward to setting up business relationship with you and hope to provide you with the best service and solution. Let us make a better world for our industry!



## Contact us

Tel: +86-755-8981 8866 Fax: +86-755-8427 6832

Email & Skype: info@chipsmall.com Web: www.chipsmall.com

Address: A1208, Overseas Decoration Building, #122 Zhenhua RD., Futian, Shenzhen, China





**Hand Crimp Tool**  
**Operating Instruction Sheet And Specifications**  
**Part No. 64001-2300**  
**Eng. No. RHT 8764**  
**(Replaces 19285-0057)**

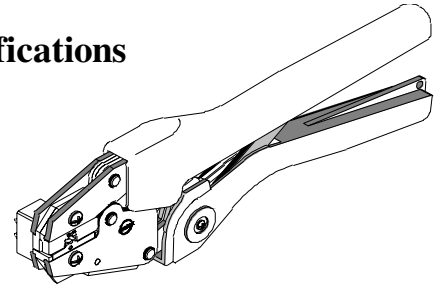

**FEATURES**

- A full cycle ratcheting hand tool ensures complete crimps
- Long handles for comfortable crimping with reduced crimping force
- A precision user-friendly terminal locator wire stop holds terminals in the proper crimping position
- Insulation crimp adjustment allows a precise insulation crimp. To meet or exceed the requirements of UL, CSA and Military Class II
- Single color-coded crimp pocket eliminates the possibility of using the wrong pocket

**SCOPE**

AviKrimp™ / InsulKrimp™ Snap Plug Receptacles 18-22 AWG.

**Testing**

**Mechanical**

The tensile test, or pull test, is a means of evaluating the mechanical properties of the crimped connections. The following charts show the UL specifications for various wire sizes. The tensile strength is shown in pounds and indicates the minimum acceptable force to break or separate the terminal from the conductor.

Wire Size (AWG)	*UL - 486 A
22	8
20	13
18	20

\*UL - 486 A - Terminals (Copper conductors only)

The following is a partial list of the product part numbers and their specifications that this tool is designed to run. We will be adding to this list and an up to date copy is available on [www.molex.com](http://www.molex.com).

Wire Size: 18 – 22 AWG 0.80 – 0.35 mm <sup>2</sup>					
Terminal No.	Terminal Eng No. (REF)	Wire Strip Length		Insul. Dia. Max.	
		In.	mm	In.	mm
19038-0001	BRA-2156	0.31	7.94	0.14	3.56
19038-0004	BRA-2180	0.31	7.94	0.14	3.56
19038-0006	BRA-2180N	0.31	7.94	0.13	3.25
19039-0001	BRA-8156	0.31	7.94	0.13	3.25
19039-0002	BRA-8156N	0.31	7.94	0.13	3.25
19039-0004	BRA-8180	0.31	7.94	0.13	3.25
19039-0005	BRA-8180N	0.31	7.94	0.13	3.33

## OPERATION

Open the tool by first closing the jaws sufficiently for the ratchet mechanism to release.

### Crimping Terminals

1. Position the terminal with the smaller part of the barrel onto the color-coded nest and push the front edge of the bigger barrel inside the locator until it stops (See Figure 1).
2. Partially close the tool to hold the terminal in place (See Figure 2).
3. Insert the properly stripped wire into the terminal barrel (See Figure 2 and 3). Cycle the tool.

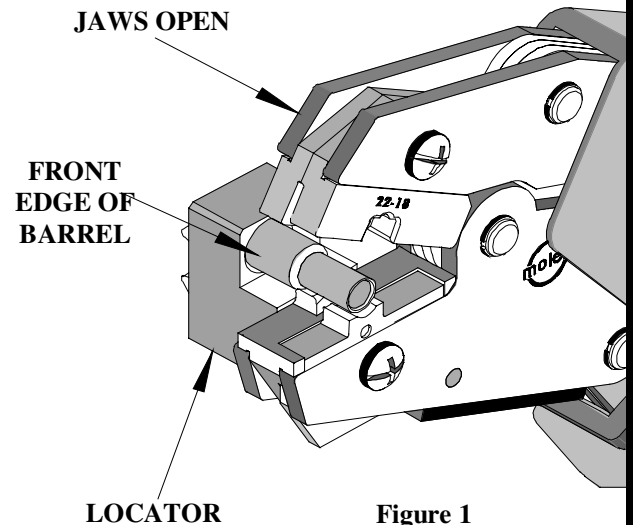

Figure 1

**Note:** The tamper proof ratchet action will not release the tool until it has been fully closed.

4. Remove the crimped terminal. Inspect for proper crimp location, and check for insulation closure.

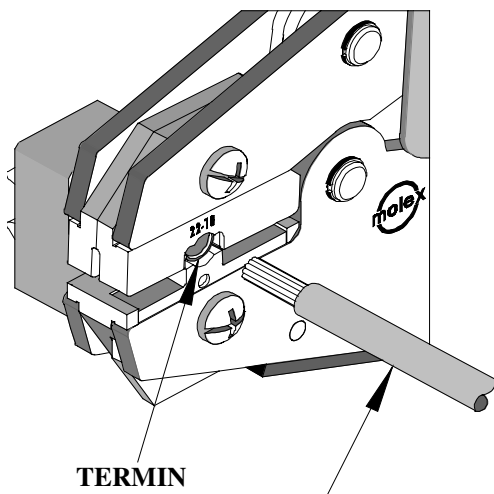

Figure 2

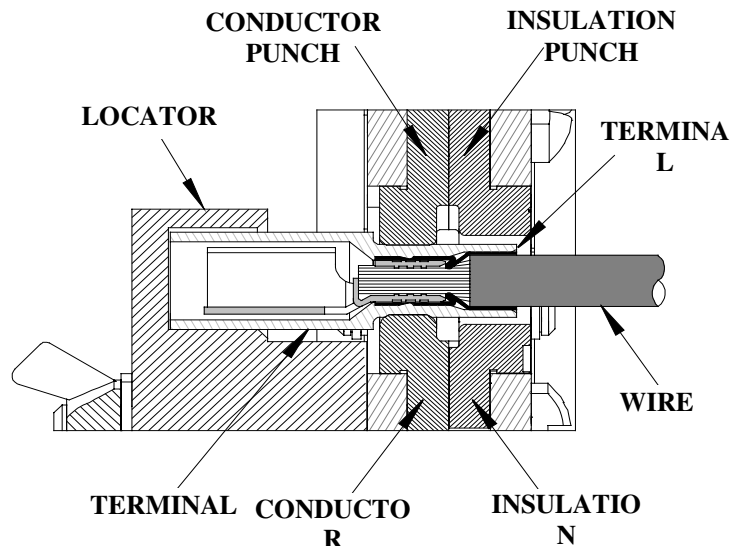

Figure 3

5. If the insulation part of the crimp needs to be adjusted, first loosen the M4 screw on the bottom tool jaw, then insert a 3/32 hex wrench (supplied) into the bottom of the lower die (See Figure 4). A clockwise (CW) rotation decreases insulation crimp while a counter-clockwise (CCW) rotation increases insulation crimp. After adjusting retighten the M4 screw.

**Note:** Whenever crimping without the locator, make sure the seam of the terminal is oriented up or down in the tool if using unbrazed product, as this will provide higher pull force values.

## Maintenance

It is recommended that each operator of the tool be made aware of, and responsible for, the following maintenance steps:

1. Remove dust, moisture and other contaminants with a clean brush, or soft, lint-free cloth.
2. Do not use any abrasive materials that could damage the tool.
3. Make certain all pins; pivot points and bearing surfaces are protected with a thin coat of high quality machine oil. Do not oil excessively. The 64001-2300 (RHT-8764) was engineered for durability, but like any fine piece of equipment it needs cleaning and lubrication for a maximum service life of trouble-free crimping. A light oil, such as 30 weight automotive oil used at the oil points shown in Figure 4, every 5,000 crimps or 3 months will significantly enhance the tool life and ensure a stable calibration.
4. When tool is not in use, keep the handles closed to prevent objects from becoming lodged in the crimping dies, and store the tool in a clean, dry area.

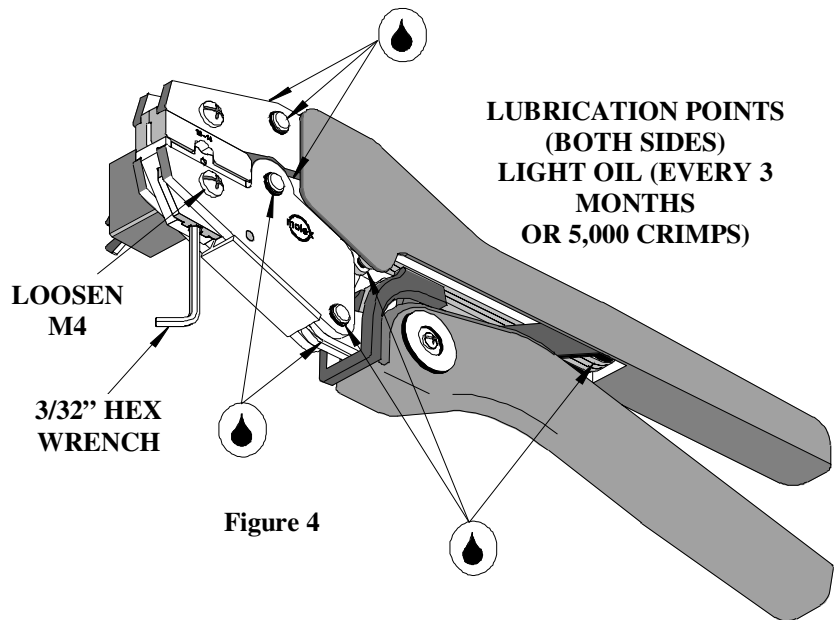

Figure 4

## Miscrimps or Jams

Should this tool ever become stuck or jammed in a partially closed position, **Do Not force the handles open or closed**. The tool will open easily by lifting the ratchet release lever (See Fig.5).

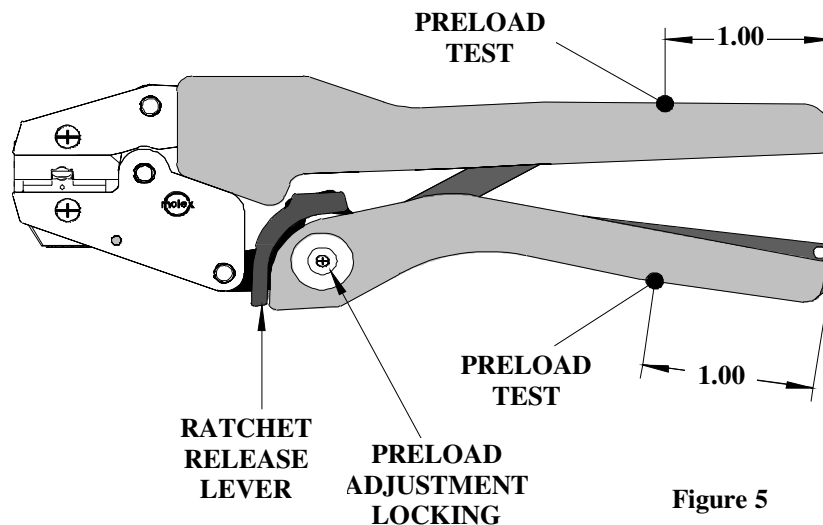

Figure 5

## How To Adjust Tool Preload (See Figure 5)

Over the life of the tool, it may be necessary to adjust tool handle preload force. Listed below are the steps required to adjust the crimping force of the hand tool to obtain proper crimp conditions:

1. Remove the screw and plastic cover washer. Note the setting wheel position.
2. Lift the setting wheel off the axle. Turn the eccentric axle with a screwdriver.
3. Turning the eccentric axle counter-clockwise (CCW) will increase handle force.
4. Replace the setting wheel to the axle, aligning the nearest notch in the setting wheel to the dowel pin.
5. Replace the plastic cover washer and screw.
6. Check the crimp specifications after tool handle preload force is adjusted.

## Tool Calibration

A Certificate of Calibration (see last page) was supplied with the tool. To recalibrate this Tool, Pin Gauge measurements should be taken in each conductor nest and compared to this chart. The tool should be lubricated prior to recalibration to ensure consistent measurements. Handle preload is factory set to 25-45 LBS. See How to Adjust Tool Preload (see Figure 5) to recalibrate.

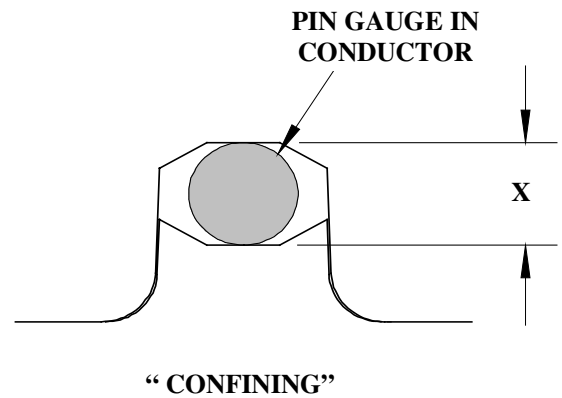

Nest Color Code	Wire Range		"X" Dimension Conductor Crimp			Crimp Inspection Marking
	AWG	mm <sup>2</sup>	Mean	Go	No Go	
Red	18 - 22	0.80 - 0.35	.089	.086	.092	o

## Warranty

This tool is for electrical terminal crimping purposes only. This tool is made of the best quality materials. All vital components are long life tested. All tools are warranted to be free of manufacturing defects for a period of **30 days**. Should such a defect occur, we will repair or exchange the tool free of charge. This repair or exchange will not be applicable to altered, misused or damaged tools. This tool is designed for hand use only. Any clamping, fixturing, or use of handle extensions voids this warranty.

Hand held crimping tools are intended for low volume, prototyping, or repair requirements only.

**Caution: Repetitive use of this tool should be avoided.**

**PARTS LIST**

Item	Order No	Description	Quantity
	<b>64001-2300</b>	<b>Hand Crimp Tool</b>	<b>(Fig. 6)</b>
1	64000-0076	Repair Kit (Springs, Pins and E-Rings)	1
2	63810-0000	Handle	1
3	64001-2175	Locator Assembly	1
4	64001-2370	Tooling Kit	1
<b>Tooling Kit Only</b>			
5	64001-2302	Conductor Punch	1
6	64001-2301	Conductor Anvil	1
7	64001-2304	Insulation Punch	1
8	64001-2303	Insulation Anvil	1
9	N/A	4 mm Dia. by 5.0 mm Lg. Roll Pins	2**
10	N/A	#10-32 by 5/16" Lg. Cup Pt. Set Screw	1**

\*\* The following purchased parts are available from an Industrial supply company such as MSC (1-800-645-7270).

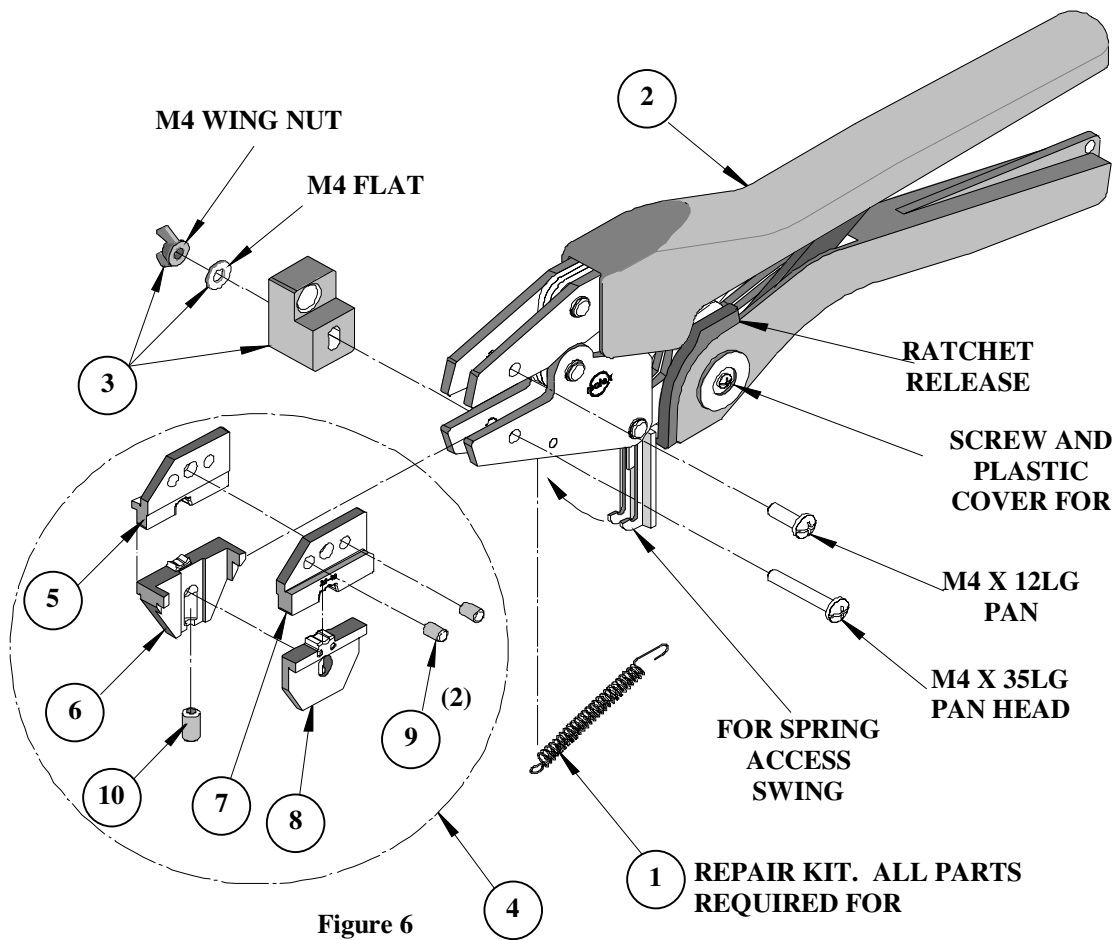
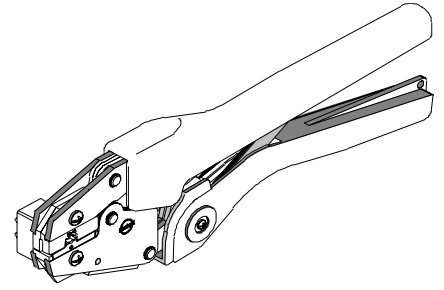

Figure 6



Certificate of Calibration

Tool Order Number \_\_\_\_\_

Tool Eng. Number \_\_\_\_\_

Tool Revision \_\_\_\_\_

Serial Number \_\_\_\_\_

Date of Manufacture \_\_\_\_\_

Handle Load Range at 1 inch from the Tips = \_\_\_\_\_

Actual = \_\_\_\_\_

Pin Gauge of Conductor Nest/Nests or Slug height if the nest is the "F" Crimp style.

Range Conductor Nest # 1 = \_\_\_\_\_ -- Actual = \_\_\_\_\_

Range Conductor Nest # 2 = \_\_\_\_\_ -- Actual = \_\_\_\_\_

Range Conductor Nest # 3 = \_\_\_\_\_ -- Actual = \_\_\_\_\_

Technician \_\_\_\_\_

Date of Calibration \_\_\_\_\_

Calibration should be done every 5,000 cycles or 3 months.
Tools should be lubricated during this operation.

Molex Application Tooling Group

1150 E. Diehl Road
Naperville, IL 60563
Tel: (630) 969-4550
Fax: (630) 505-0049