



Chipsmall Limited consists of a professional team with an average of over 10 year of expertise in the distribution of electronic components. Based in Hongkong, we have already established firm and mutual-benefit business relationships with customers from,Europe,America and south Asia,supplying obsolete and hard-to-find components to meet their specific needs.

With the principle of "Quality Parts,Customers Priority,Honest Operation,and Considerate Service",our business mainly focus on the distribution of electronic components. Line cards we deal with include Microchip,ALPS,ROHM,Xilinx,Pulse,ON,Everlight and Freescale. Main products comprise IC,Modules,Potentiometer,IC Socket,Relay,Connector.Our parts cover such applications as commercial,industrial, and automotives areas.

We are looking forward to setting up business relationship with you and hope to provide you with the best service and solution. Let us make a better world for our industry!



Contact us

Tel: +86-755-8981 8866 Fax: +86-755-8427 6832

Email & Skype: info@chipsmall.com Web: www.chipsmall.com

Address: A1208, Overseas Decoration Building, #122 Zhenhua RD., Futian, Shenzhen, China





**Air Powered Crimp Tool Head
Operating Instruction Sheet
And Specifications
Part No. 64005-0900
Eng. No. AT 7050
(Replaces 19283-0048)**

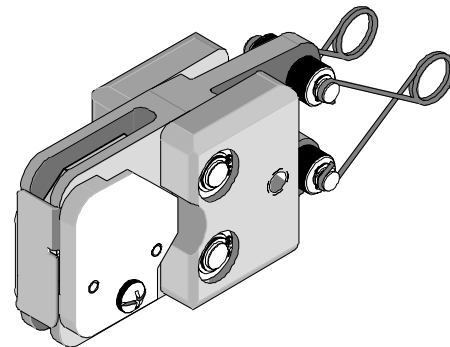

FEATURES

- Quick-change tool head for the 19279-0001 (AT-200)
- Tooling kit is interchangeable with other kits in the 64001 and 64003 Series
- A precision user-friendly terminal locator wire stop holds terminals in the proper crimping position
- Pneumatic powered crimp tools help reduce fatigue and discomfort from repetitive manual crimping

SCOPE

Nylon closed end connectors 12–22 AWG. This tool head is intended for use in the 19279-0001 (AT-200) either hand held or with optional bench adapter 19078-0307 (ATBA) and foot switch.

Testing

Mechanical

The tensile test or pull test is a means of evaluating the mechanical properties of the crimped connections. The following charts show the UL specifications for various wire sizes. The tensile strength is shown in pounds and indicates the minimum acceptable force to break or separate terminal from the conductor.

Wire Size (AWG)	UL – 486 C
22	8
20	10
18	10
16	15
14	25
12	35

* UL – 486 C – Closed end connectors and Wire Nuts.

The following is a partial list of the product part numbers and their specifications that this tool is designed to run. We will be adding to this list and an up to date copy is available on www.molex.com.

Terminal No.	Terminal Eng No. (REF)	Wire Size		Wire Combinations
		AWG	mm ²	
19160-0009	NC-2212	12 - 22	(3.30-0.35)	See Chart 1
19160-0010	NC-2212-L	12 - 22	(3.30-0.35)	See Chart 1
19160-0011	NC-2212-BA	12 - 22	(3.30-0.35)	See Chart 1

OPERATION

Refer to the instruction manual for the 19279-0001 (AT200) for mounting this crimp tool head.

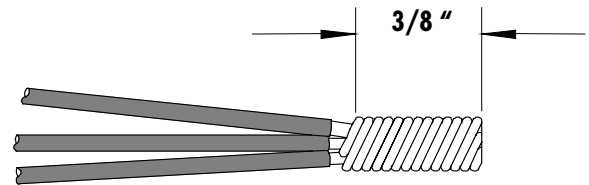

Wire Preparation

Pre-twisted wire not required for OEM applications. For Solid Wire strip leads to 3/8 of an inch. Insert into connector and crimp (OEM only).

For stranded wire strip leads to approximately 3/4 of an inch. Twist the wire combination even and tight. Trim stripped pre-twisted area to 3/8 of an inch and insert into connector and crimp. For more information follow the Quality Crimping Handbook.

CHART 1

Wire Type	Wire Gauge (AWG)					Rating
	14	16	18	20	22	
Stranded or Solid	1	1				UL & CSA
Stranded or Solid	1		1			UL & CSA
Stranded or Solid	1		2			UL & CSA
Stranded or Solid	1		1	1		UL & CSA
Stranded or Solid	1		1	2		UL & CSA
Stranded or Solid	1		1		1	UL & CSA
Stranded or Solid	1		1		2	UL & CSA
Stranded or Solid	1		1		3	UL & CSA
Stranded or Solid	1			1		UL & CSA
Stranded or Solid	1			2		UL & CSA
Stranded or Solid	1			3		UL & CSA
Stranded or Solid	1				1	UL & CSA
Stranded or Solid	1				2	CSA
Stranded or Solid	1				3	CSA
Stranded or Solid	1				4	CSA
Stranded or Solid	1		1	1	1	CSA
Stranded or Solid		3				UL & CSA
Stranded or Solid		2				UL & CSA
Stranded or Solid		2	1			UL & CSA
Stranded only		2	2			UL & CSA
Stranded or Solid		2		1		UL & CSA
Stranded or Solid		2		2		UL & CSA
Stranded or Solid		2			1	UL & CSA
Stranded or Solid		2			2	UL & CSA
Stranded or Solid		2			3	UL & CSA
Stranded or Solid		2	1	1		UL & CSA
Stranded or Solid		2	1		1	UL & CSA
Stranded or Solid		2		1	1	UL & CSA
Stranded or Solid		1		1	2	UL & CSA
Stranded or Solid		1	1			UL & CSA
Stranded or Solid		1	1			UL & CSA
Stranded or Solid		1	2			UL & CSA
Stranded or Solid		1	3			UL & CSA
Stranded or Solid		1		1		UL & CSA
Stranded or Solid		1		2		UL & CSA
Stranded or Solid		1		3		UL & CSA
Stranded or Solid		1		4		UL & CSA
Stranded or Solid		1			1	UL & CSA
Stranded or Solid		1			2	UL & CSA
Stranded or Solid		1			3	UL & CSA
Stranded or Solid		1			4	UL & CSA
Stranded or Solid		1			5	UL & CSA
Stranded or Solid		1	1	1	1	UL & CSA
Stranded or Solid		1	2	1	1	UL & CSA
Stranded or Solid		1	3	1	1	UL & CSA
Stranded or Solid		1	4	1	1	UL & CSA
Stranded or Solid		1	1	1	2	UL & CSA

Wire Type	Wire Gauge (AWG)					Rating
	14	16	18	20	22	
Stranded or Solid		1	2	1		UL & CSA
Stranded or Solid		1	2		1	UL & CSA
Stranded or Solid		1	2		2	UL & CSA
Stranded or Solid			1	1	1	UL & CSA
Stranded or Solid			1	2	1	UL & CSA
Stranded or Solid			1	1	2	UL & CSA
Stranded Only			5			UL only
Stranded or Solid			4			UL & CSA
Stranded or Solid			4	1		UL & CSA
Stranded or Solid			4		1	UL & CSA
Stranded or Solid			3			UL & CSA
Stranded or Solid			3	1		UL & CSA
Stranded or Solid			3	2		UL & CSA
Stranded or Solid			3		1	UL & CSA
Stranded or Solid			3		2	UL & CSA
Stranded or Solid			3		3	UL & CSA
Stranded or Solid			3	1	1	UL & CSA
Stranded or Solid			2			UL & CSA
Stranded or Solid			2	1		UL & CSA
Stranded or Solid			2	2		UL & CSA
Stranded or Solid			2	3		UL & CSA
Stranded or Solid			2		1	UL & CSA
Stranded or Solid			2		2	UL & CSA
Stranded or Solid			2		3	UL & CSA
Stranded or Solid			2	1	1	UL & CSA
Stranded or Solid			2	2	1	UL & CSA
Stranded or Solid			2	3	1	UL & CSA
Stranded or Solid			2	1	2	UL & CSA
Stranded or Solid			2	1	3	UL & CSA
Stranded or Solid			1	1		UL & CSA
Stranded or Solid			1	2		UL & CSA
Stranded or Solid			1	3		UL & CSA
Stranded or Solid			1	4		UL & CSA
Stranded or Solid			1	5		UL & CSA
Stranded or Solid			1		1	UL & CSA
Stranded or Solid			1		2	UL & CSA
Stranded or Solid			1		3	UL & CSA
Stranded or Solid			1		4	UL & CSA
Stranded or Solid			1		5	UL & CSA
Stranded or Solid			1	1	1	UL & CSA
Stranded or Solid			1	2	1	UL & CSA
Stranded or Solid			1	3	1	UL & CSA
Stranded or Solid			1	4	1	UL & CSA
Stranded or Solid			1	1	2	UL & CSA

Wire Combinations for Nylon- Insulated Closed End Connectors Part No. 191600009 (NC-2212)						
Wire Type	Wire Gauge (AWG)					Rating
	14	16	18	20	22	
Stranded or Solid			1	1	3	UL & CSA
Stranded or Solid			1	1	4	UL & CSA
Stranded or Solid			1	2	2	UL & CSA
Stranded or Solid			1	2	3	UL & CSA
Stranded or Solid			1	3	2	UL & CSA
Stranded or Solid				6		UL & CSA
Stranded or Solid				5		UL & CSA
Stranded or Solid				5	1	UL & CSA
Stranded or Solid				4		UL & CSA
Stranded or Solid				4	1	UL & CSA
Stranded or Solid				4	2	UL & CSA
Stranded or Solid				3		UL & CSA
Stranded or Solid				3	1	UL & CSA
Stranded or Solid				3	2	UL & CSA
Stranded or Solid				3	3	UL & CSA
Stranded or Solid				2		UL & CSA

Wire Combinations for Nylon- Insulated Closed End Connectors Part No. 191600009 (NC-2212)						
Wire Type	Wire Gauge (AWG)					Rating
	14	16	18	20	22	
Stranded or Solid				2	1	UL & CSA
Stranded or Solid				2	2	UL & CSA
Stranded or Solid				2	3	UL & CSA
Stranded or Solid				2	4	UL & CSA
Stranded or Solid				1	1	UL & CSA
Stranded or Solid				1	2	UL & CSA
Stranded or Solid				1	3	UL & CSA
Stranded or Solid				1	4	UL & CSA
Stranded or Solid				1	5	UL & CSA
Stranded or Solid					6	UL & CSA
Stranded or Solid					5	UL & CSA
Stranded or Solid					4	UL & CSA
Stranded or Solid					3	UL & CSA
Stranded or Solid					2	UL & CSA

Crimping Terminals

1. Hold Air Head crimp tool with the locator facing up. Insert the closed end connector in the slot (12-22). Make sure that the shoulder of the connector is resting on the locator plate (See Figure 1).
2. Place pre-twisted wire into closed-end connector. Then press lever on air tool (See Figure 2 and 3). Release after jaws have closed.

Caution: Never operate this tool without the supplied safety shield in place. Never place fingers in the tool nests.

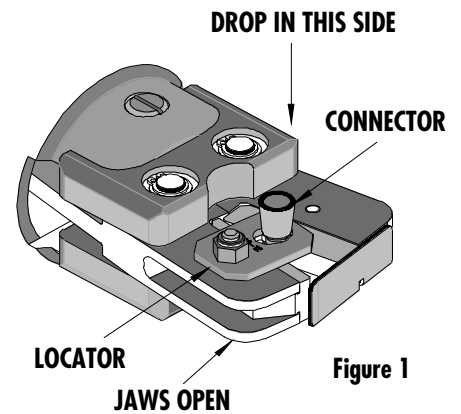

Figure 1

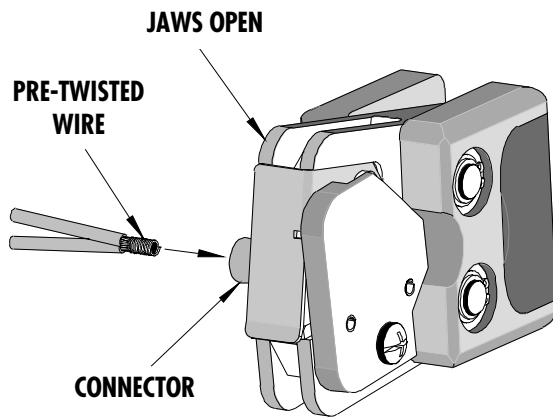

Figure 2

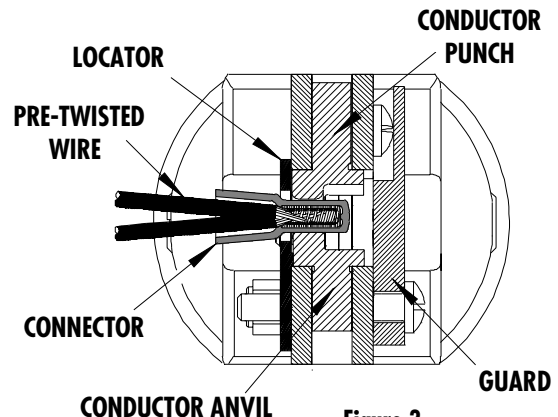

Figure 3

3. Remove the crimp and inspect for proper crimp location, and check for insulation closure. Molex offers a Crimp Inspection Handbook for closed barrel industrial product. See our website or contact your sales engineer.

Note: Whenever crimping without the locator, make sure the seam of the terminal is oriented up or down in the tool if using unbrazed product, as this will provide higher pull force values.

Maintenance

It is recommended that each operator of the tool be made aware of, and responsible for, the following maintenance steps:

1. Remove dust, moisture and other contaminants with a clean brush, or soft, lint-free cloth.
2. Do not use any abrasive materials that could damage the tool.
3. Make certain all pins; pivot points and bearing surfaces are protected with a thin coat of high quality machine oil. Do not oil excessively. The 64005-0900 (AT-7050) was engineered for durability, but like any fine piece of equipment it needs cleaning and lubrication for a maximum service life of trouble-free crimping. A light oil, such as 30 weight automotive oil used at the oil points shown in Figure 4, every 5,000 crimps or monthly will significantly enhance the tool life and ensure a stable calibration.
4. When tool is not in use store the tool in a clean, dry area.

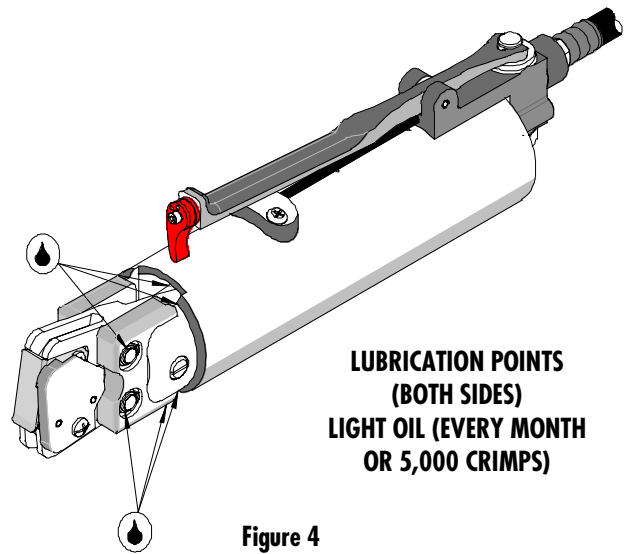
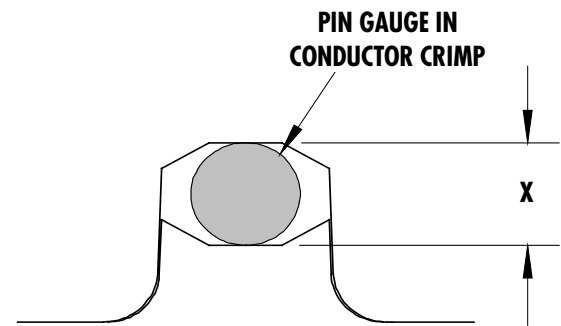

Figure 4

Tool Calibration

A Certificate of Calibration (see last page) was supplied with the tool. To recalibrate this tool, pin gauge measurements should be taken in each conductor nest and compared to this chart. The tool should be lubricated prior to recalibration to ensure consistent measurements.



" Confining " Crimp

Wire Range		"X" Dimension Conductor Crimp		
AWG	mm ²	Mean	Go	No Go
12 - 22	0.35 – 3.30	.102	.099	.106

Warranty

This tool is for electrical terminal crimping purposes only. This tool is made of the best quality materials. All vital components are long-life tested. All tools are warranted to be free of manufacturing defects for a period of **30 days**. Should such a defect occur, we would repair or exchange the tool free of charge. This repair or exchange will not be applicable to alter, misused or damaged tools.

PARTS LIST

Item	Order No	Description	Quantity
	64005-0900	Crimp Tool Head	(Fig. 5)
1	64005-0000	Basic Air Tool Head	1
2	64001-0975	Locator Assembly	1
3	64001-0970	Tooling Kit	1
4	64005-0605	Guard	1
5	N/A	3MM by 6 Long Roll Pin	2**
6	N/A	M4 by 25 Long Freedrive Pan Head Screw	1**
Tooling Kit Only			
7	64001-0901	Conductor Punch	1
8	64001-0902	Conductor Anvil	1

** The following purchased parts are available from an Industrial supply company such as MSC (1-800-645-7270).

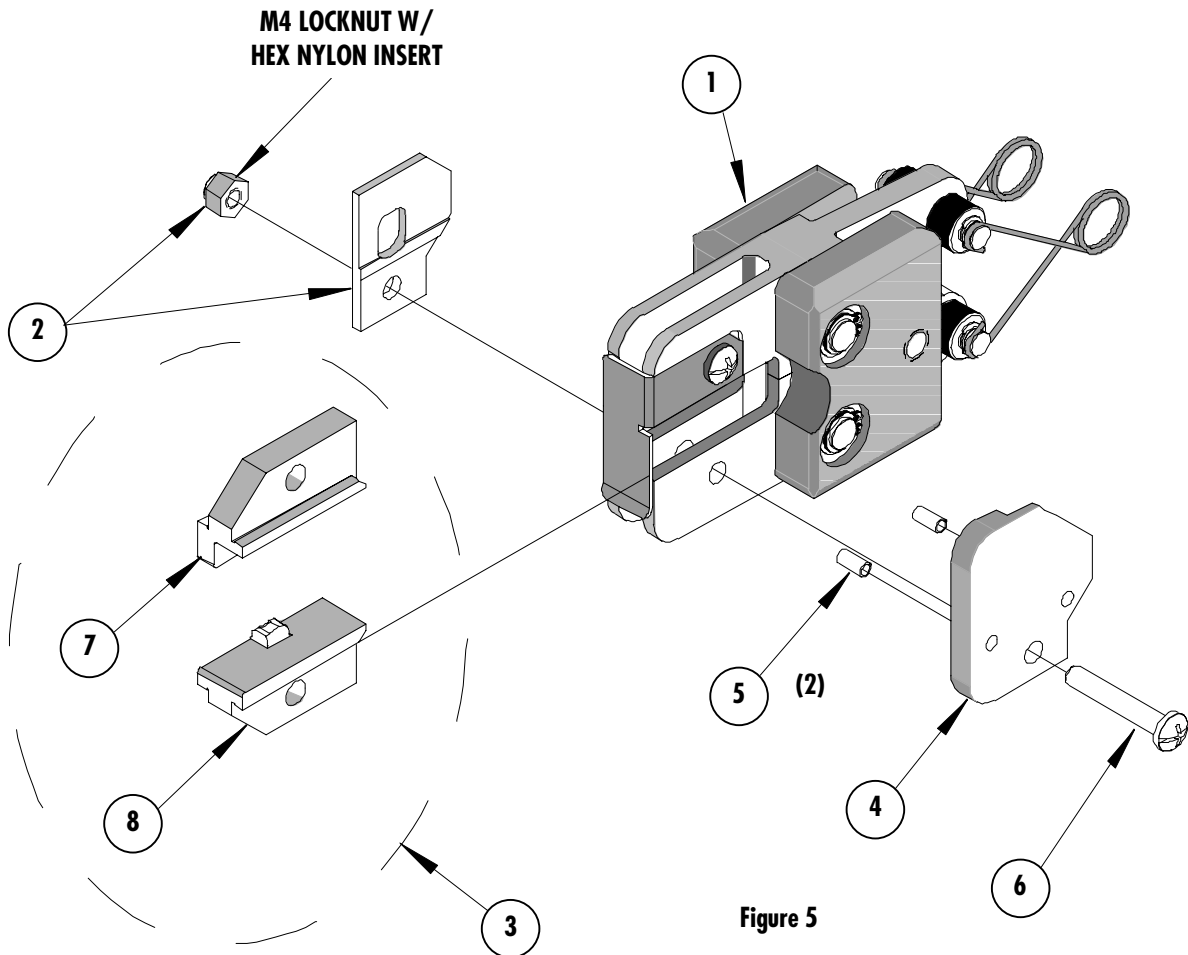

Parts List (Continued)

Item	Order No.	Description	Quantity
	64005-0000	Basic Air Tool Head	(Fig. 6)
1.	64005-0103	Nose Guard	1
2.	64000-0077	Repair Kit (Springs, Rods, Pivots, Rings, and Washers)	1
3.	N/A	M4 by 12LG. Freedrive Pan Head Screw	1**
4.	N/A	M4 by 30LG. Freedrive Pan Head Screw	1**
5.	N/A	3/16" by 3/8" Long Dowel Pin	1**

** The following purchased parts are available from an Industrial supply company such as (MSC 1-800-645-7270).

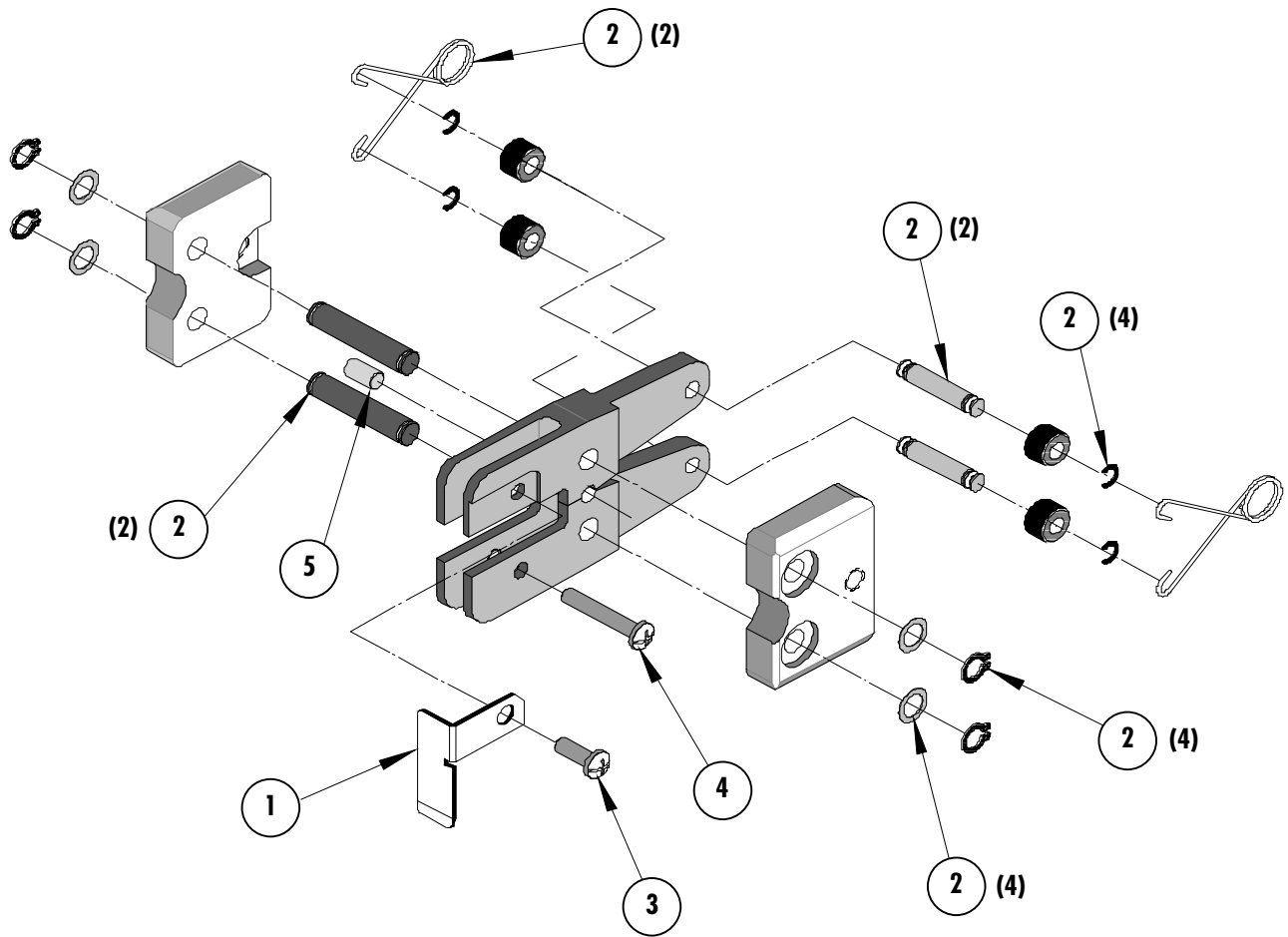
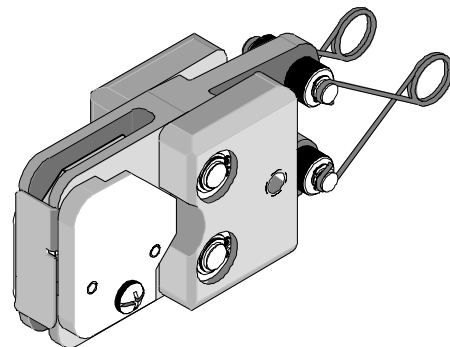

Figure 6



Certificate of Calibration

Tool Order Number _____

Tool Eng. Number _____

Tool Revision _____

Serial Number _____

Date of Manufacture _____

Pin Gauge of Conductor Nest/Nests or Slug height if the nest is the "F" Crimp style.

Range Conductor Nest # 1 = _____ -- Actual = _____

Range Conductor Nest # 2 = _____ -- Actual = _____

Range Conductor Nest # 3 = _____ -- Actual = _____

Technician _____

Date of Calibration _____

Calibration should be done every 5,000 cycles or 3 months.
Tools should be lubricated during this operation.

Molex Application Tooling Group

1150 E. Diehl Road
Naperville, IL 60563
Tel: (630) 969-4550;
Fax: (630) 505-0049